

**FINISH: GALVANISED**

**AP ASSOCIATED PROJECTS** COMMERCIAL BUILDERS,  
PROJECT MANAGERS,  
PLANNERS & DESIGNERS

T 03 8787 3000 F 03 8787 3025  
48-58 Cyber Loop, Dandenong South VIC 3175

Rev	Date	Description

ALL DIMENSIONS IN (mm)  
UNLESS OTHERWISE SPECIFIED  
BREAK ALL SHARP EDGES

TOLERANCES  
(BEFORE PAINTING  
& AFTER PLATING)  
X ± 1.00  
X.X ± 0.50  
X.XX ± 0.10  
ANGLES ± 0.5°

**A01- RENDER**  
**CLIENT: RFA**  
**PROJ. NO.: TBA**  
**PART NO.: --**  
**Revision --**  
**Page 1**

<b>HEAVY DUTY SHELF</b> W915 x D780 x T33 FOR 838 RACK		
<b>PRODUCT CODE: RFA6184</b>		
Date:	23/10/2023	<b>DO NOT SCALE</b>
Drawn by	PS	
Checked by	--	
		<b>Scale@A3 1:10</b>

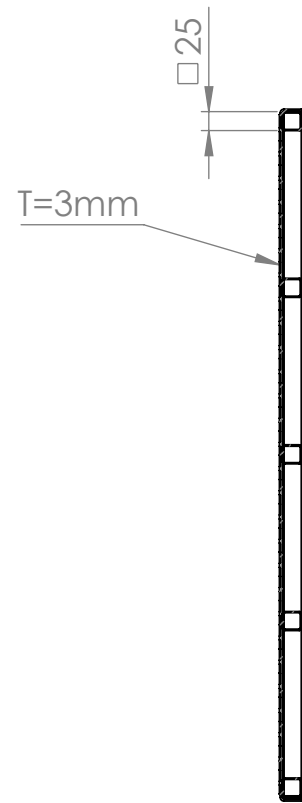
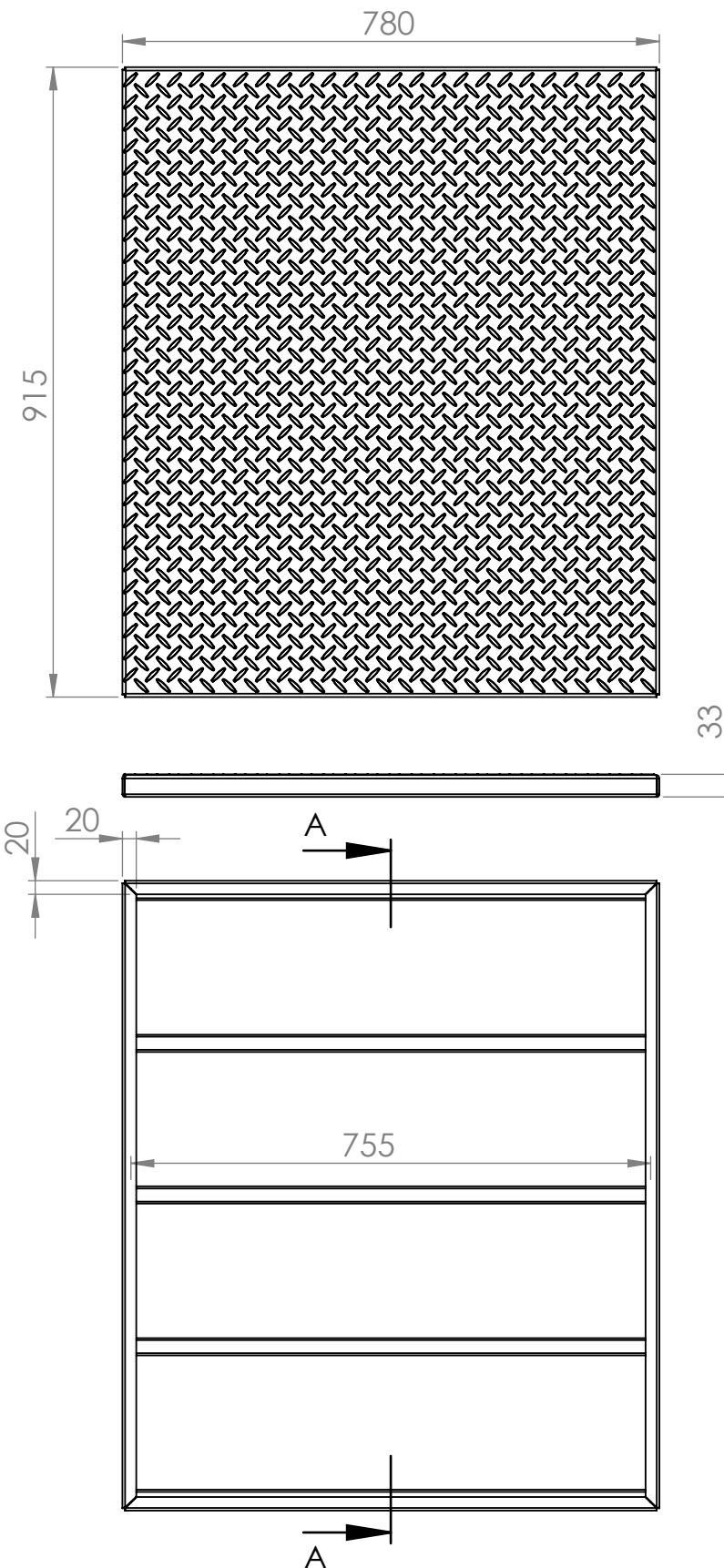
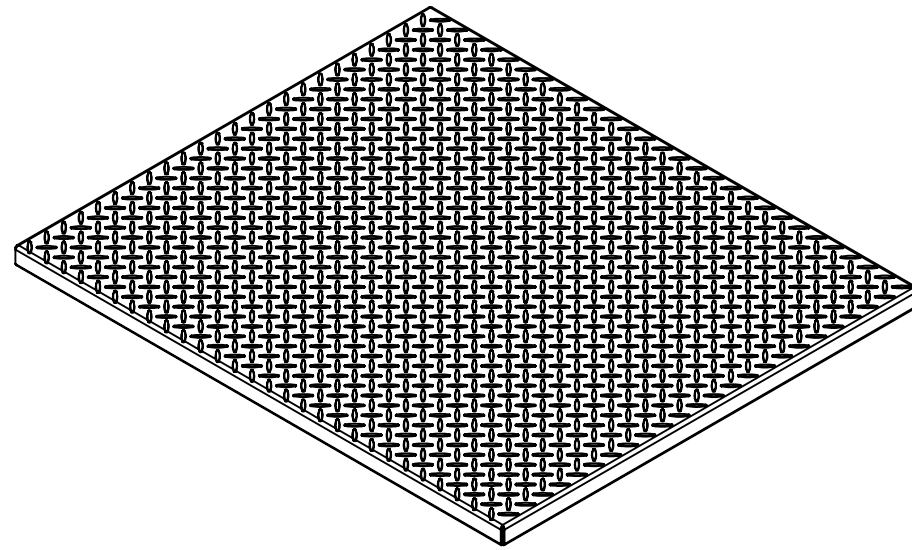

SECTION A-A

Rev	Date	Description

ALL DIMENSIONS IN (mm)  
UNLESS OTHERWISE SPECIFIED  
BREAK ALL SHARP EDGES

TOLERANCES  
(BEFORE PAINTING  
& AFTER PLATING)  
X ± 1.00  
X.X ± 0.50  
X.XX ± 0.10  
ANGLES ± 0.5°

**A02- DIMENSIONS**  
CLIENT: RFA  
PROJ. NO.: TBA  
PART NO.: --  
Revision --  
Page 2

**HEAVY DUTY SHELF**  
W915 x D780 x T33  
FOR 838 RACK

PRODUCT CODE: **RFA6184**

Date: 23/10/2023  
Drawn by PS  
Checked by --

