

FINISH: P/C MATTE BLACK

**AP ASSOCIATED PROJECTS** COMMERCIAL BUILDERS,  
PROJECT MANAGERS,  
PLANNERS & DESIGNERS

T 03 8787 3000 F 03 8787 3025  
48-58 Cyber Loop, Dandenong South VIC 3175

Rev	Date	Description

ALL DIMENSIONS IN (mm)  
UNLESS OTHERWISE SPECIFIED  
BREAK ALL SHARP EDGES

TOLERANCES  
(BEFORE PAINTING  
& AFTER PLATING)  
X ± 1.00  
X.X ± 0.50  
X.XX ± 0.10  
ANGLES ± 0.5°

A01- RENDER  
CLIENT: RFA  
PROJ. NO.: TBA  
PART NO.: --  
Revision --  
Page 1

HEAVY DUTY GONDOLA W1940 x H1600 x D1067 START BAY		
PRODUCT CODE: <b>RFA6084</b>	Date: 18/07/2024	
Drawn by PS	Checked by --	DO NOT SCALE
		Scale@A3 1:20

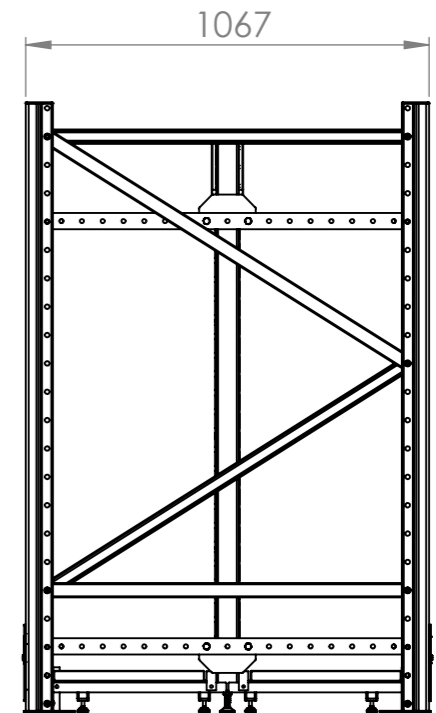
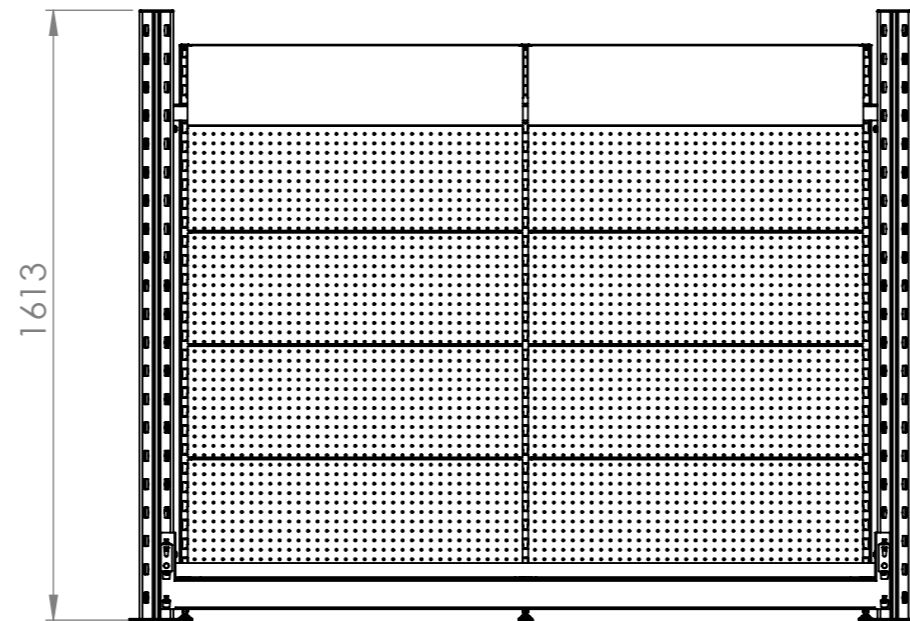
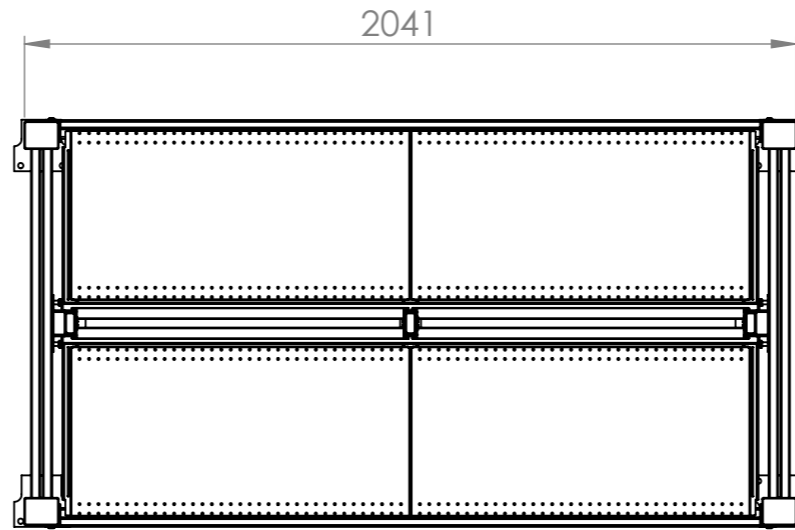
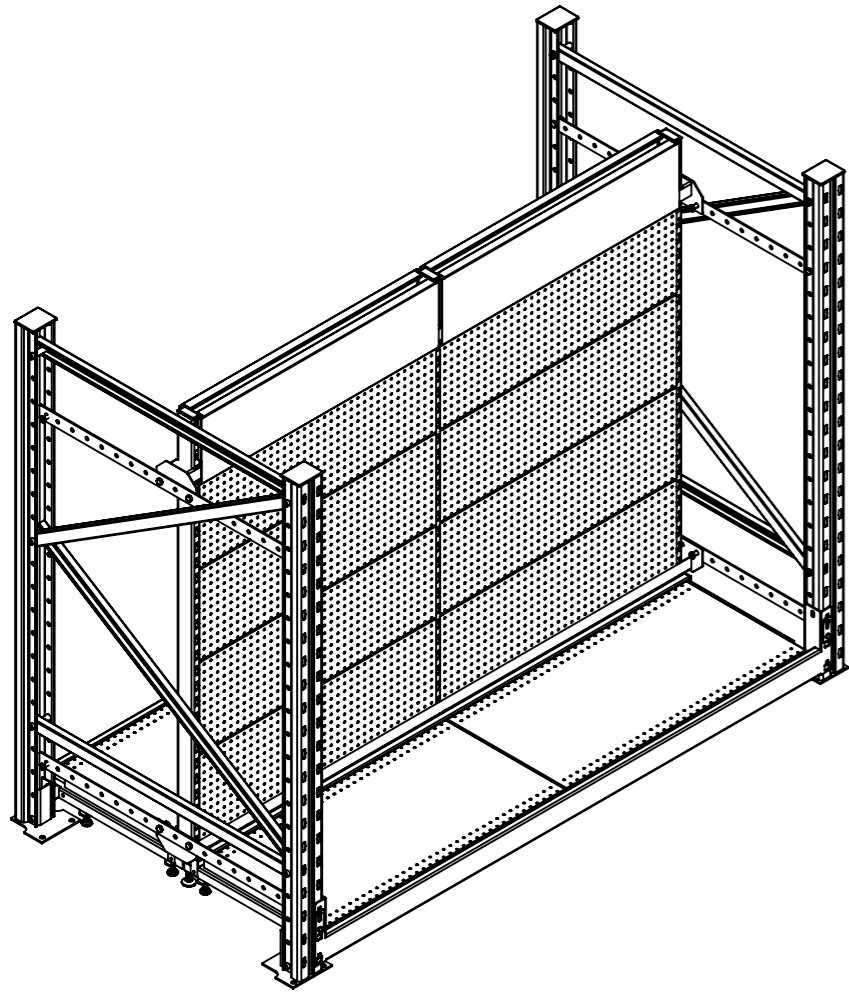

Rev	Date	Description

ALL DIMENSIONS IN (mm)  
UNLESS OTHERWISE SPECIFIED  
BREAK ALL SHARP EDGES

TOLERANCES  
(BEFORE PAINTING  
& AFTER PLATING)  
X ± 1.00  
X.X ± 0.50  
X.XX ± 0.10  
ANGLES ± 0.5°

**A02- DIMENSIONS**

CLIENT: RFA  
PROJ. NO.: TBA  
PART NO.: --  
Revision --  
Page 2

HEAVY DUTY GONDOLA  
W1940 x H1600 x D1067

PRODUCT CODE: **RFA6084**

Date: 18/07/2024

Drawn by PS

Checked by --

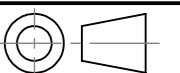

DO NOT SCALE

Scale@A3 1:20

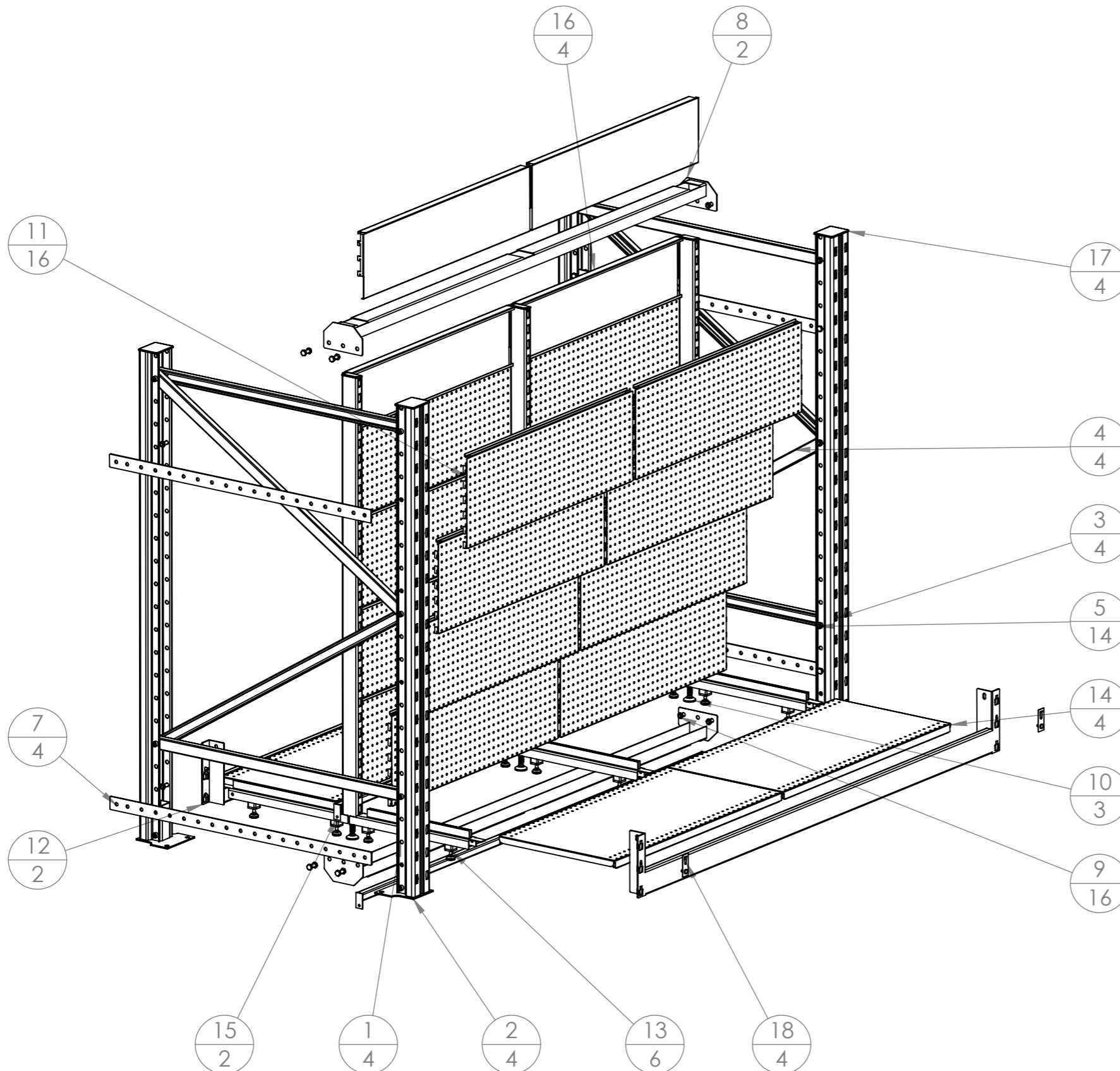

ITEM NO.	PartNo	DESCRIPTION	QTY.
1	RFA6140	1600mm(H) PALLET RACK UPRIGHT-POST	4
2	RFA6105	FOOT FOR PALLET RACK UPRIGHT	4
3	RFA6108	1067mm(D) RACK - HORIZONTAL BRACE	4
4	RFA6109	1067mm(D) RACK - DIAGONAL BRACE	4
5	RFA6114	M10x65mm BOLT - FOR BRACING	14
6	RFA6115	M10 SPACER FOR BOLT	4
7	RFA6118	1067mm(D) ADJUSTABLE HOLE BAR	4
8	RFA6120	2000mm(W) MID PANEL CHANNEL	2
9	RFA6116	M10x30mm NUT AND BOLT SET	16
10	RFA6122	H1600 MID PANEL POST	3
11	RFA2307	W900 xH300 CLIP IN PANEL	16
12	RFA6034	1860mm(W) x 80mm(H) x50mm(D) REVERS LUG STEP BEAM	2
13	RFA6125	450mm(D) STRUT BAR	6
14	RFA6127	900mm(W) x 450mm(D) STEEL SHELF	4
15	RFA6131	1940mm(W) DROP IN BACK BAR	2
16	RFA6137	W900 SIGNAGE CLIPPER PANEL	4
17	RFA6139	PLASTIC CAP - FOR TOP OF UPRIGHT	4
18	RFA6036	SAFETY PIN	4

Rev	Date	Description

ALL DIMENSIONS IN (mm)  
UNLESS OTHERWISE SPECIFIED  
BREAK ALL SHARP EDGES

TOLERANCES  
(BEFORE PAINTING  
& AFTER PLATING)  
X ± 1.00  
X.X ± 0.50  
X.XX ± 0.10  
ANGLES ± 0.5°

A03- EXPLODED

CLIENT: RFA  
PROJ. NO.: TBA  
PART NO.: --  
Revision --  
Page 3

HEAVY DUTY GONDOLA  
W1940 x H1600 x D1067  
START BAY

PRODUCT CODE: **RFA6084**

Date: 18/07/2024

Drawn by PS

Checked by --

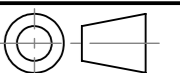

DO NOT SCALE

Scale@A3 1:20