

FINISH: P/C MATTE BLACK

**AP ASSOCIATED PROJECTS** COMMERCIAL BUILDERS,  
PROJECT MANAGERS,  
PLANNERS & DESIGNERS

T 03 8787 3000 F 03 8787 3025  
48-58 Cyber Loop, Dandenong South VIC 3175

Rev	Date	Description

ALL DIMENSIONS IN (mm)  
UNLESS OTHERWISE SPECIFIED  
BREAK ALL SHARP EDGES

TOLERANCES  
(BEFORE PAINTING  
& AFTER PLATING)  
X ± 1.00  
X.X ± 0.50  
X.XX ± 0.10  
ANGLES ± 0.5°

A01- RENDER  
CLIENT: RFA  
PROJ. NO.: TBA  
PART NO.: --  
Revision --  
Page 1

1220mm(D) GONDOLA END PERFORATED PANEL		
PRODUCT CODE: <b>RFA6080</b>		
Date: 3/10/2023		DO NOT SCALE
Drawn by PS		
Checked by --		Scale@A3 1:20

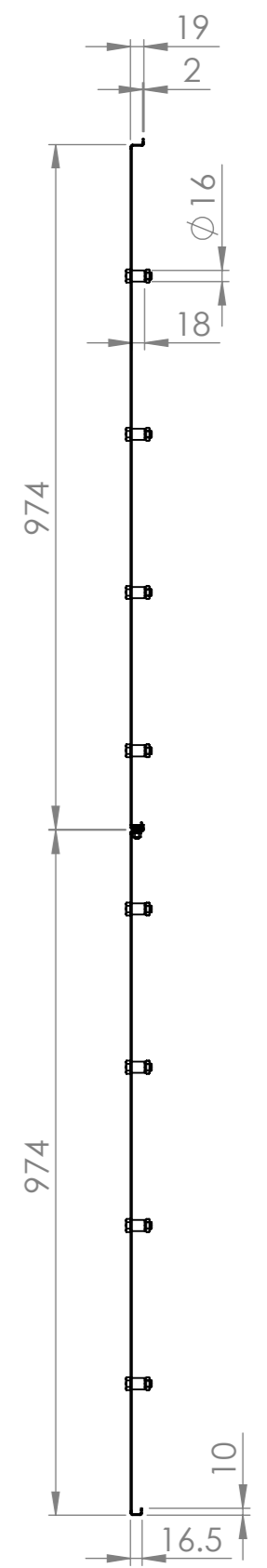
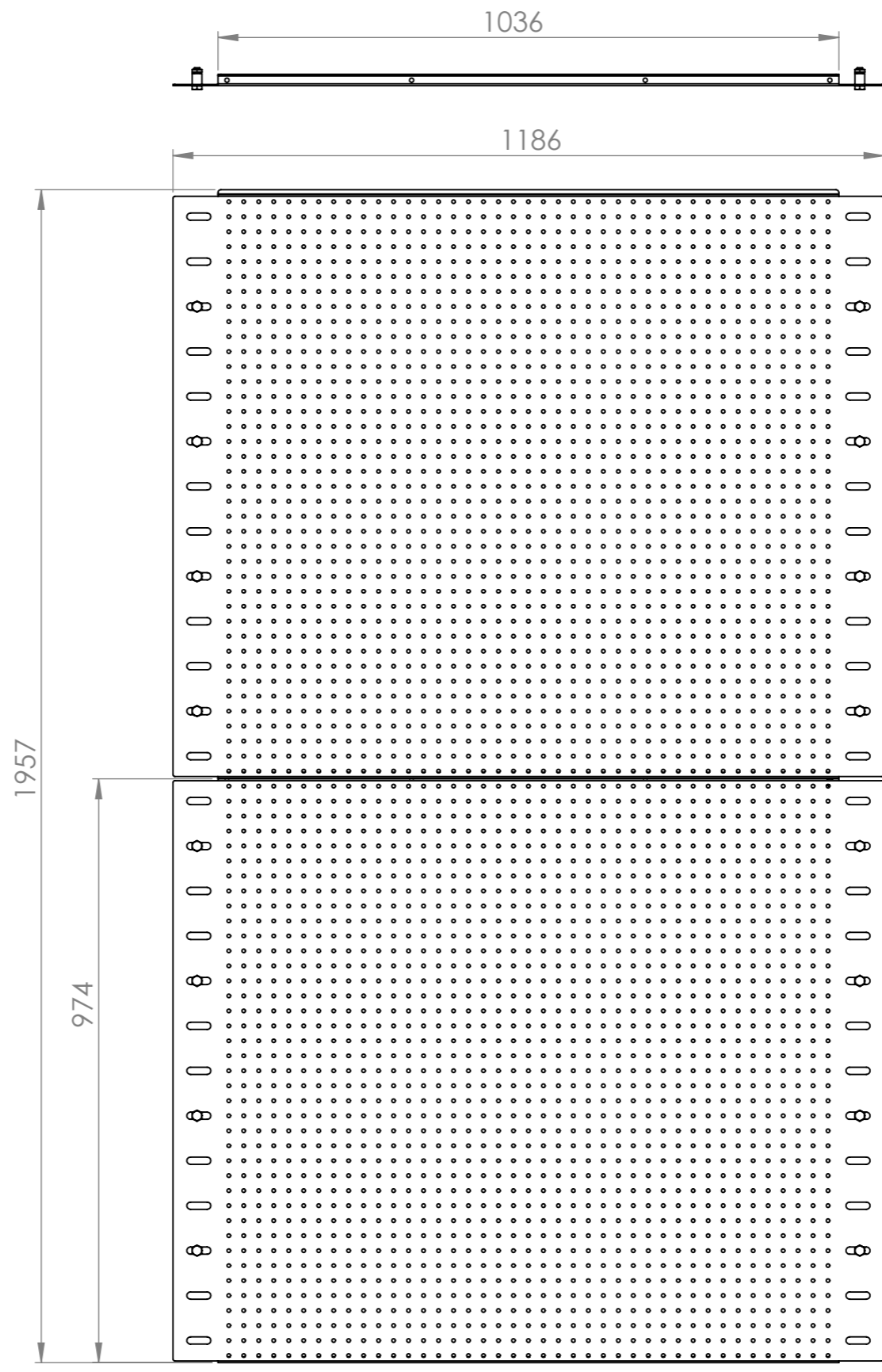
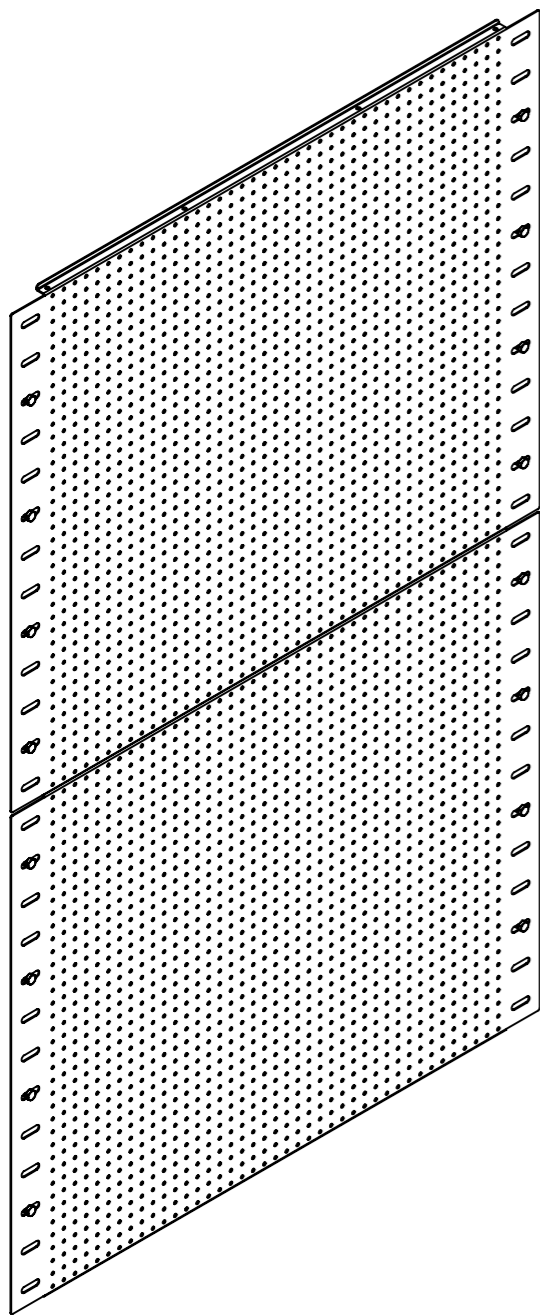

Rev	Date	Description

ALL DIMENSIONS IN (mm)  
UNLESS OTHERWISE SPECIFIED  
BREAK ALL SHARP EDGES

TOLERANCES  
(BEFORE PAINTING  
& AFTER PLATING)  
X ± 1.00  
X.X ± 0.50  
X.XX ± 0.10  
ANGLES ± 0.5°

**A02- DIMENSIONS**

CLIENT: RFA  
PROJ. NO.: TBA  
PART NO.: --  
Revision --  
Page 2

1220mm(D)  
GONDOLA END PERFORATED PANEL

PRODUCT CODE: **RFA6080**

Date: 3/10/2023

Drawn by PS

Checked by --

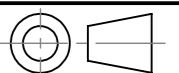

DO NOT SCALE

Scale@A3 1:10

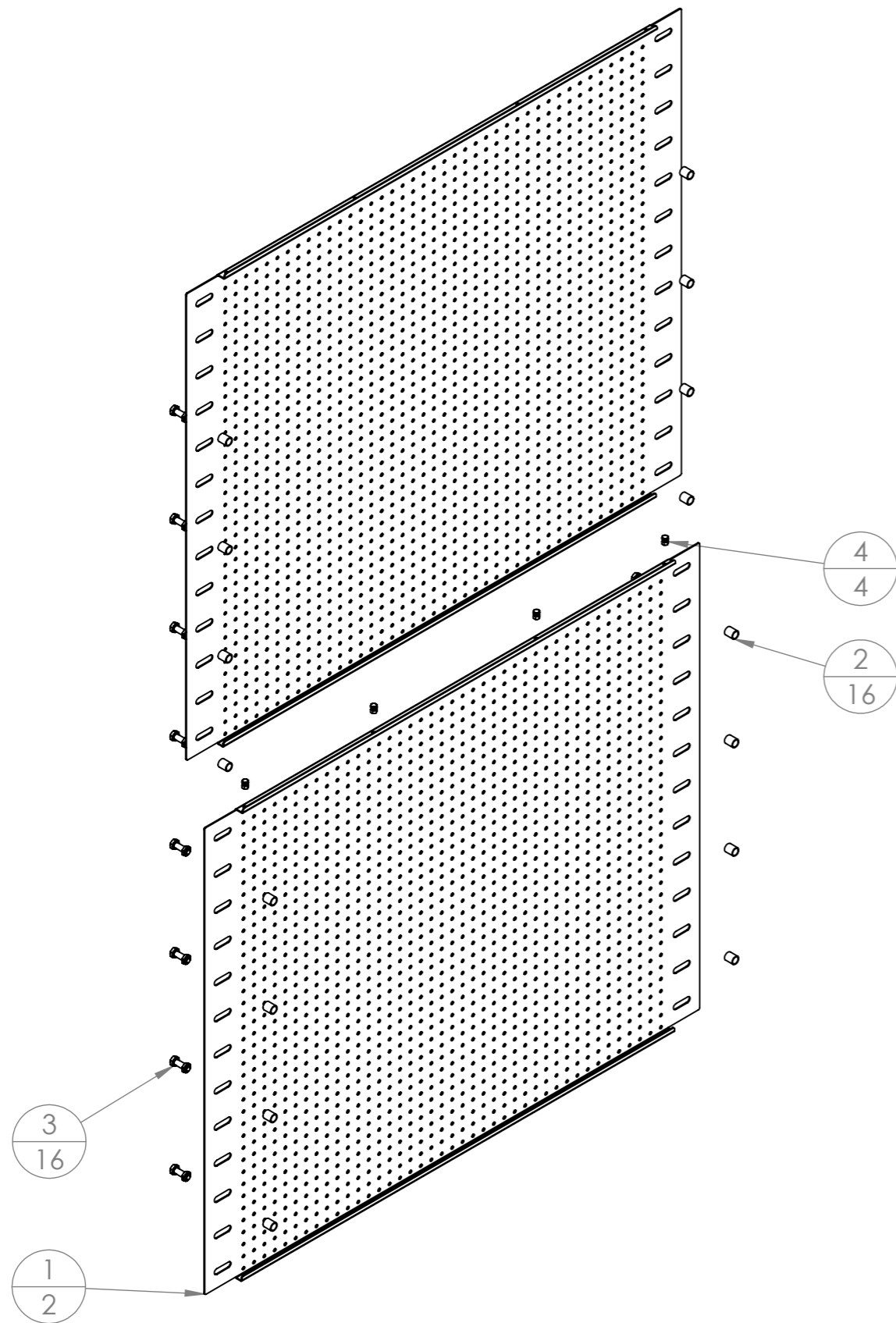

ITEM NO.	PartNo	DESCRIPTION	QTY.
1	RFA6152	1220mm(D) GONDOLA END PERFORATED PANEL	2
2	RFA6153	18mm(D) SPACER	16
3	RFA6116	M10x30mm NUT AND BOLT SET	16
4	RFA6154	M6x12mm NUT AND BOLT SET	4

Rev	Date	Description

ALL DIMENSIONS IN (mm)  
 UNLESS OTHERWISE SPECIFIED  
 BREAK ALL SHARP EDGES

TOLERANCES  
 (BEFORE PAINTING  
 & AFTER PLATING)  
 X ± 1.00  
 X.X ± 0.50  
 X.XX ± 0.10  
 ANGLES ± 0.5°

**A03- EXPLODED**  
 CLIENT: RFA  
 PROJ. NO.: TBA  
 PART NO.: --  
 Revision --  
 Page 3

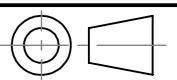
1220mm(D) GONDOLA END PERFORATED PANEL		
-		
PRODUCT CODE: <b>RFA6080</b>		DO NOT SCALE Scale@A3 1:10
Date:	3/10/2023	
Drawn by	PS	
Checked by	--	