

FINISH: P/C MATTE BLACK

AP ASSOCIATED PROJECTS COMMERCIAL BUILDERS,
PROJECT MANAGERS,
PLANNERS & DESIGNERS

T 03 8787 3000 F 03 8787 3025
48-58 Cyber Loop, Dandenong South VIC 3175

| Rev | Date | Description |
|-----|------|-------------|
| | | |
| | | |
| | | |
| | | |

ALL DIMENSIONS IN (mm)
UNLESS OTHERWISE SPECIFIED
BREAK ALL SHARP EDGES

TOLERANCES
(BEFORE PAINTING
& AFTER PLATING)
X ± 1.00
X.X ± 0.50
X.XX ± 0.10
ANGLES ± 0.5°

A01- RENDER
CLIENT: RFA
PROJ. NO.: TBA
PART NO.: --
Revision --
Page 1

| | | |
|---|------------------|---------------|
| 1940mm(W) x 1067mm(D) -600mm MID PANEL SET | | |
| PRODUCT CODE: RFA6059 | Date: 29/09/2023 | |
| Drawn by PS | Checked by -- | DO NOT SCALE |
| | | Scale@A3 1:20 |

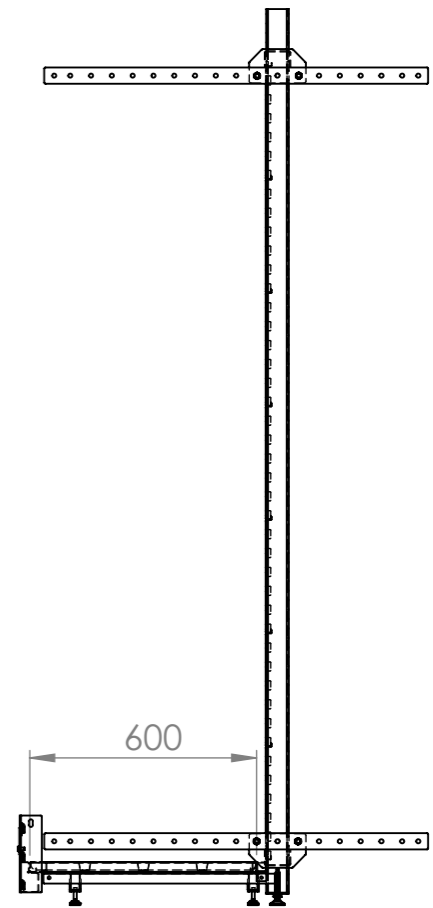
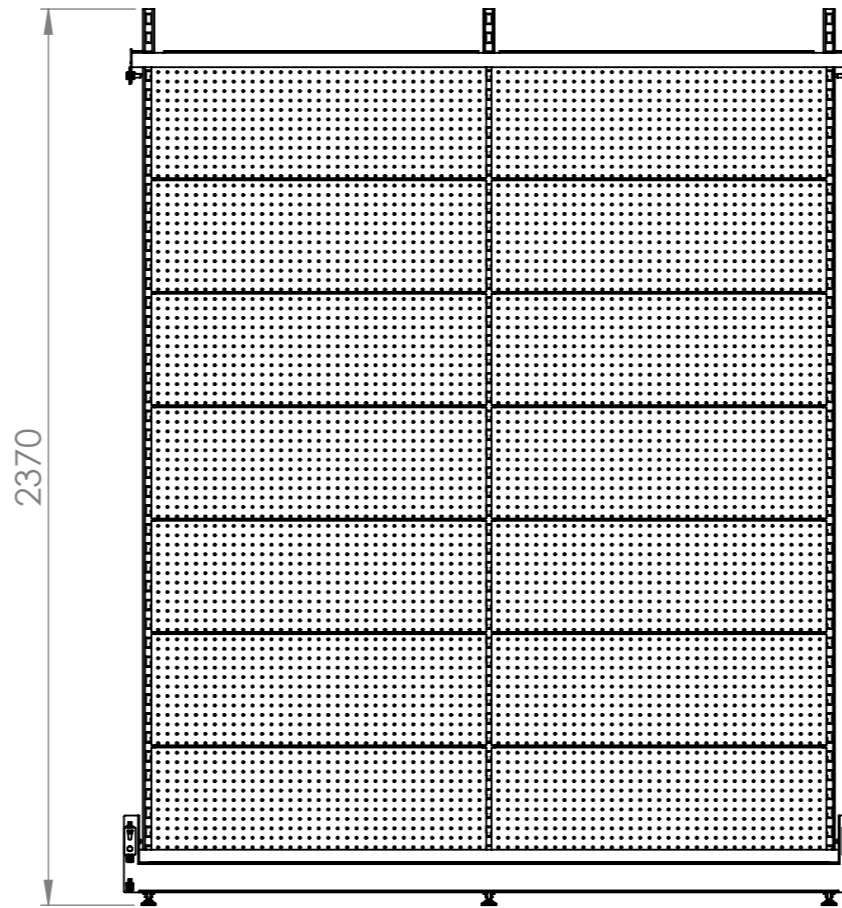
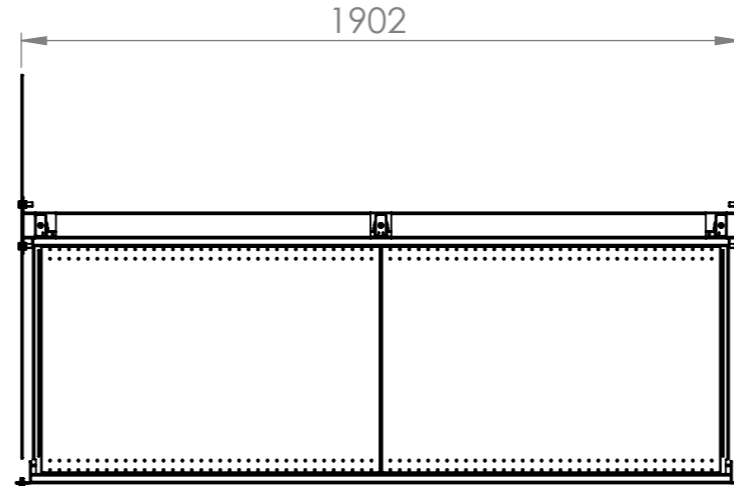
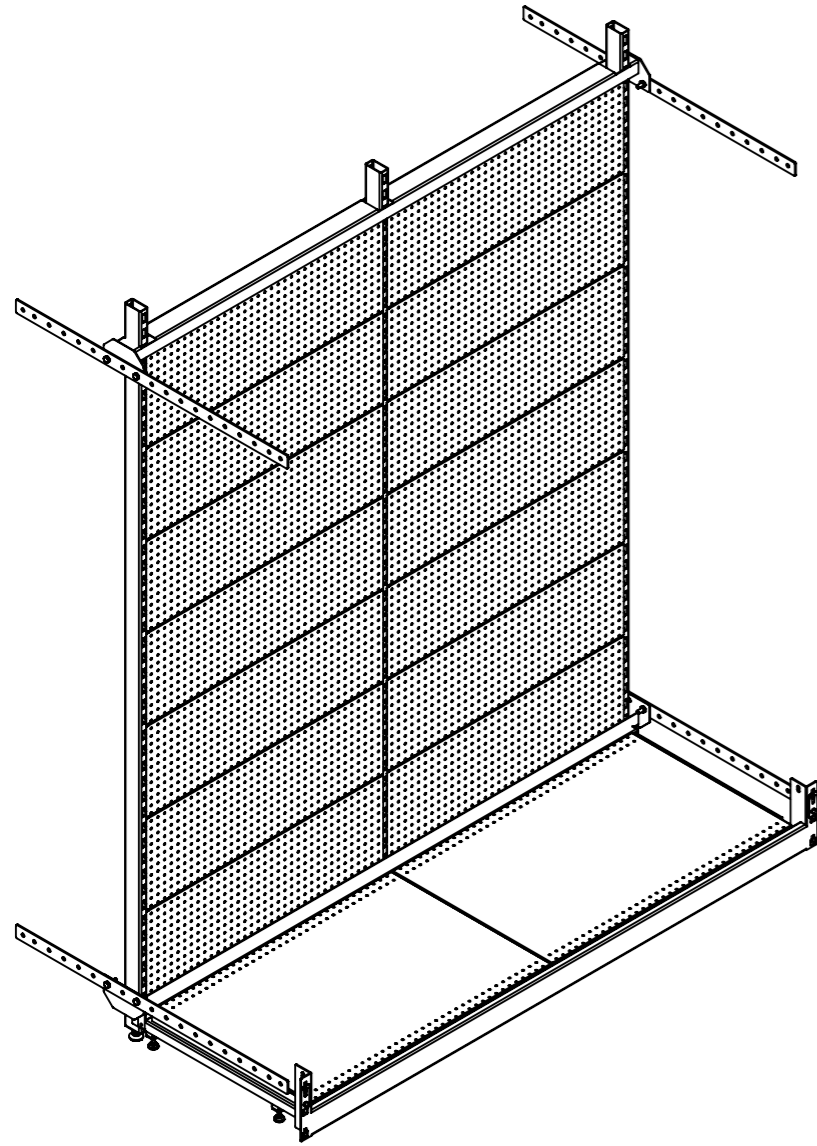

| Rev | Date | Description |
|-----|------|-------------|
| | | |
| | | |
| | | |

ALL DIMENSIONS IN (mm)
UNLESS OTHERWISE SPECIFIED
BREAK ALL SHARP EDGES

TOLERANCES
(BEFORE PAINTING
& AFTER PLATING)
X ± 1.00
X.X ± 0.50
X.XX ± 0.10
ANGLES ± 0.5°

A02- DIMENSIONS
CLIENT: RFA
PROJ. NO.: TBA
PART NO.: --
Revision --
Page 2

| | | |
|--|------------------|---------------|
| 1940mm(W) x 1067mm(D) - 600mm MID PANEL SET | | |
| PRODUCT CODE: RFA6059 | Date: 29/09/2023 | |
| Drawn by PS | Checked by -- | Scale@A3 1:20 |

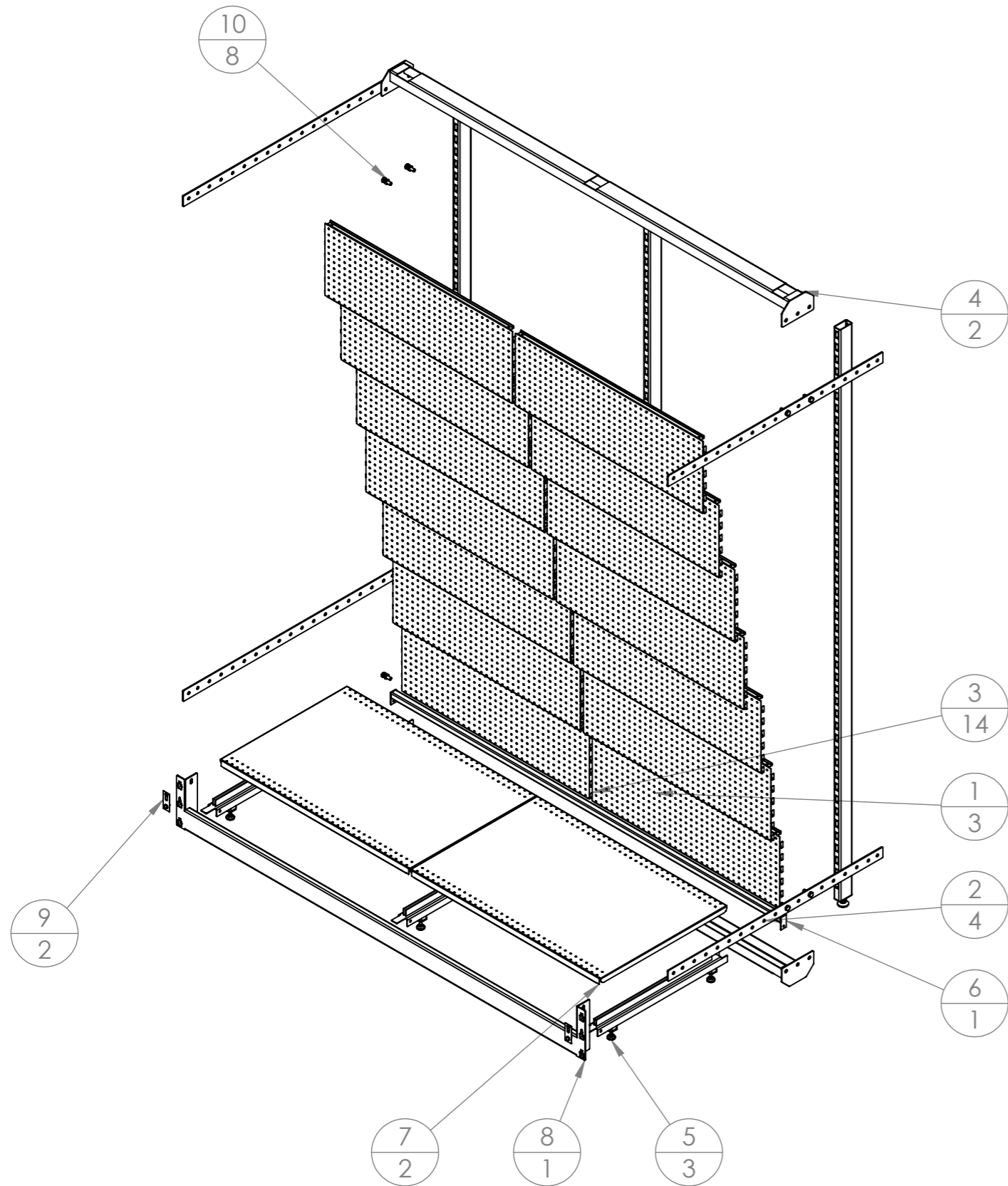

| ITEM NO. | PartNo | DESCRIPTION | QTY. |
|----------|---------|---|------|
| 1 | RFA2300 | 2400mm(H) MID PANEL POST | 3 |
| 2 | RFA6118 | 1067mm(D) ADJUSTABLE HOLE BAR | 4 |
| 3 | RFA6124 | 900mm(W) x 300mm(H) CLIP IN PANEL | 14 |
| 4 | RFA6120 | 2000mm(W) MID PANEL CHANNEL | 2 |
| 5 | RFA6126 | 600mm(D) STRUT BAR | 3 |
| 6 | RFA6131 | 1940mm(W) DROP IN BACK BAR | 1 |
| 7 | RFA6128 | 900mm(W) x 600mm(D) STEEL SHELF | 2 |
| 8 | RFA6034 | 1860mm(W) x 80mm(H) x50mm(D) REVERS LUG STEP BEAM | 1 |
| 9 | RFA6036 | SAFETY PIN | 2 |
| 10 | RFA6116 | M10x30mm NUT AND BOLT SET | 8 |

| Rev | Date | Description |
|-----|------|-------------|
| | | |
| | | |
| | | |

ALL DIMENSIONS IN (mm)
 UNLESS OTHERWISE SPECIFIED
 BREAK ALL SHARP EDGES

TOLERANCES
 (BEFORE PAINTING
 & AFTER PLATING)
 X ± 1.00
 X.X ± 0.50
 X.XX ± 0.10
 ANGLES ± 0.5°

A03- EXPLODED
 CLIENT: RFA
 PROJ. NO.: TBA
 PART NO.: --
 Revision --
 Page 3

| | | |
|---|------------------|---------------|
| 1940mm(W) x 1067mm(D) -600mm MID PANEL SET | | |
| PRODUCT CODE: RFA6059 | Date: 29/09/2023 | |
| Drawn by PS | Checked by -- | DO NOT SCALE |
| | | Scale@A3 1:20 |