

FINISH: P/C MATTE BLACK

AP ASSOCIATED PROJECTS COMMERCIAL BUILDERS,
PROJECT MANAGERS,
PLANNERS & DESIGNERS

T 03 8787 3000 F 03 8787 3025
48-58 Cyber Loop, Dandenong South VIC 3175

Rev	Date	Description

ALL DIMENSIONS IN (mm)
UNLESS OTHERWISE SPECIFIED
BREAK ALL SHARP EDGES

TOLERANCES
(BEFORE PAINTING
& AFTER PLATING)
X ± 1.00
X.X ± 0.50
X.XX ± 0.10
ANGLES ± 0.5°

A01- RENDER

CLIENT: RFA

PROJ. NO.: TBA

PART NO.: --

Revision --

Page 1

2760mm(W) x 838mm(D) - 450
MID PANEL SET

PRODUCT CODE: **RFA6056**

Date: 28/09/2023

Drawn by PS

Checked by --

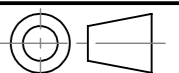

DO NOT SCALE

Scale@A3 1:20

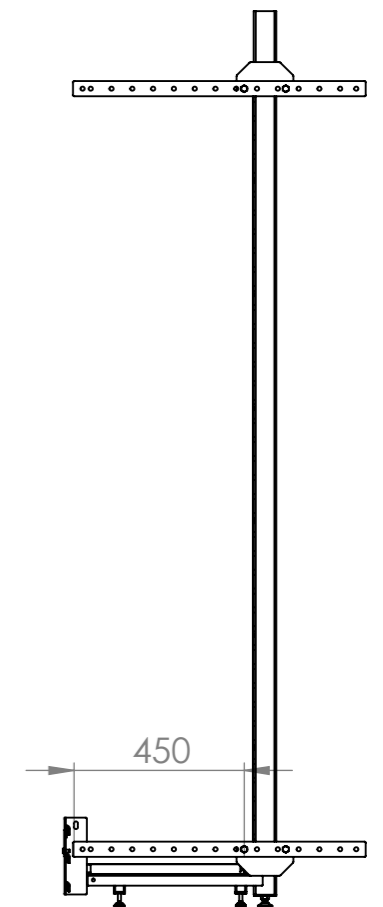
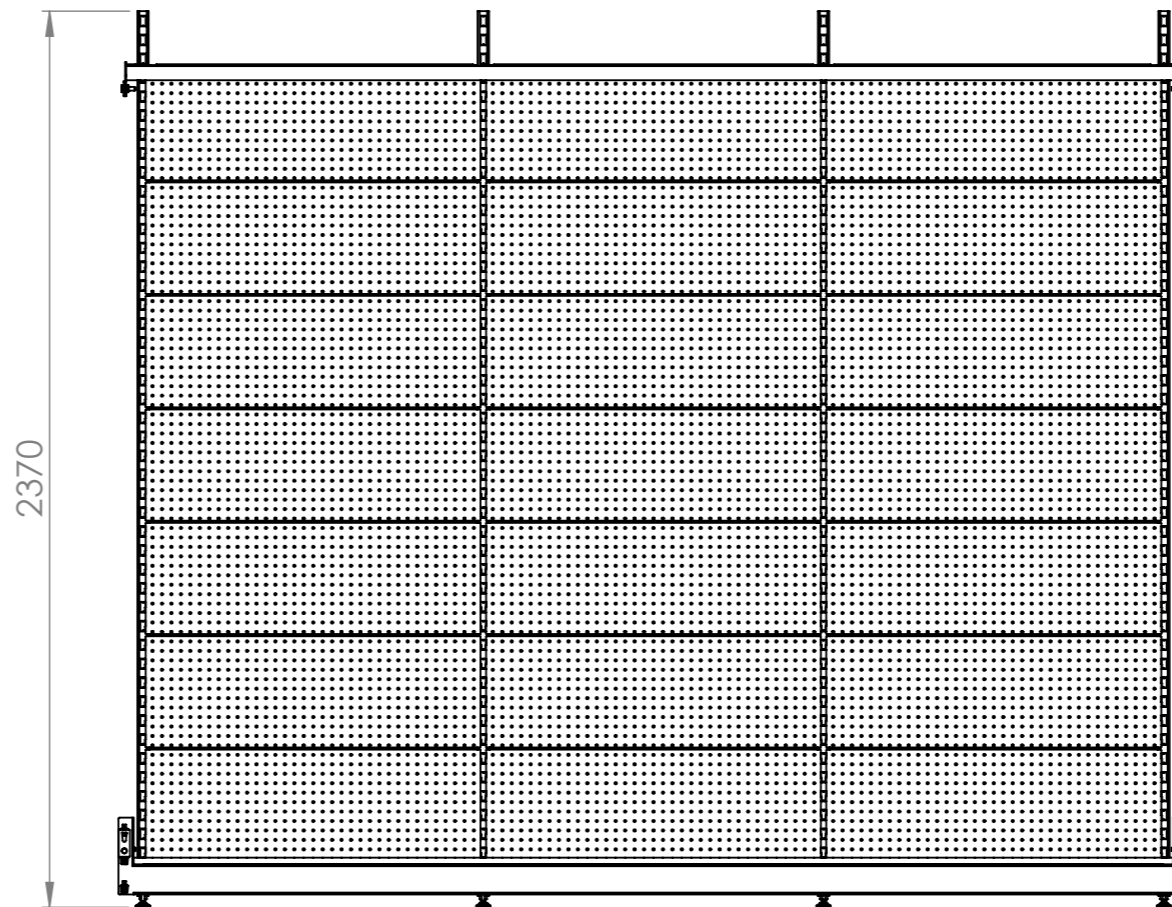
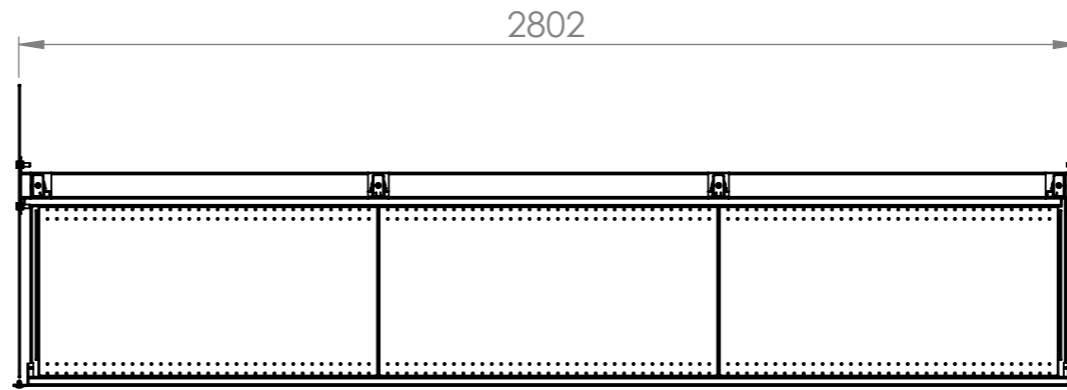
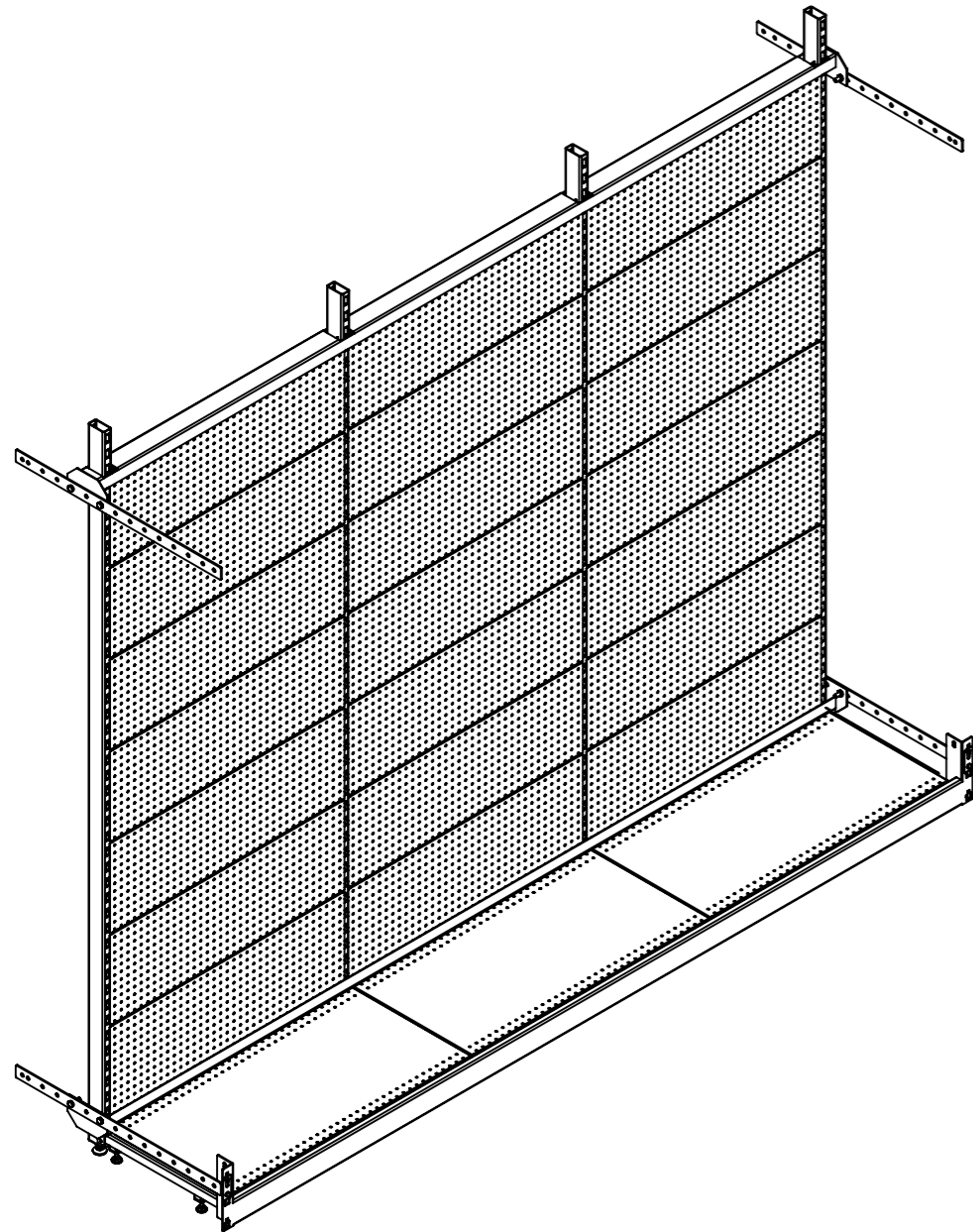

Rev	Date	Description

ALL DIMENSIONS IN (mm)
UNLESS OTHERWISE SPECIFIED
BREAK ALL SHARP EDGES

TOLERANCES
(BEFORE PAINTING
& AFTER PLATING)
X ± 1.00
X.X ± 0.50
X.XX ± 0.10
ANGLES ± 0.5°

A02- DIMENSIONS

CLIENT: RFA
PROJ. NO.: TBA
PART NO.: --
Revision --
Page 2

2760mm(W) x 838mm(D) - 450
MID PANEL SET

PRODUCT CODE: **RFA6056**

Date: 28/09/2023

Drawn by PS

Checked by --

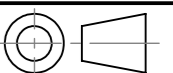

DO NOT SCALE

Scale@A3 1:20

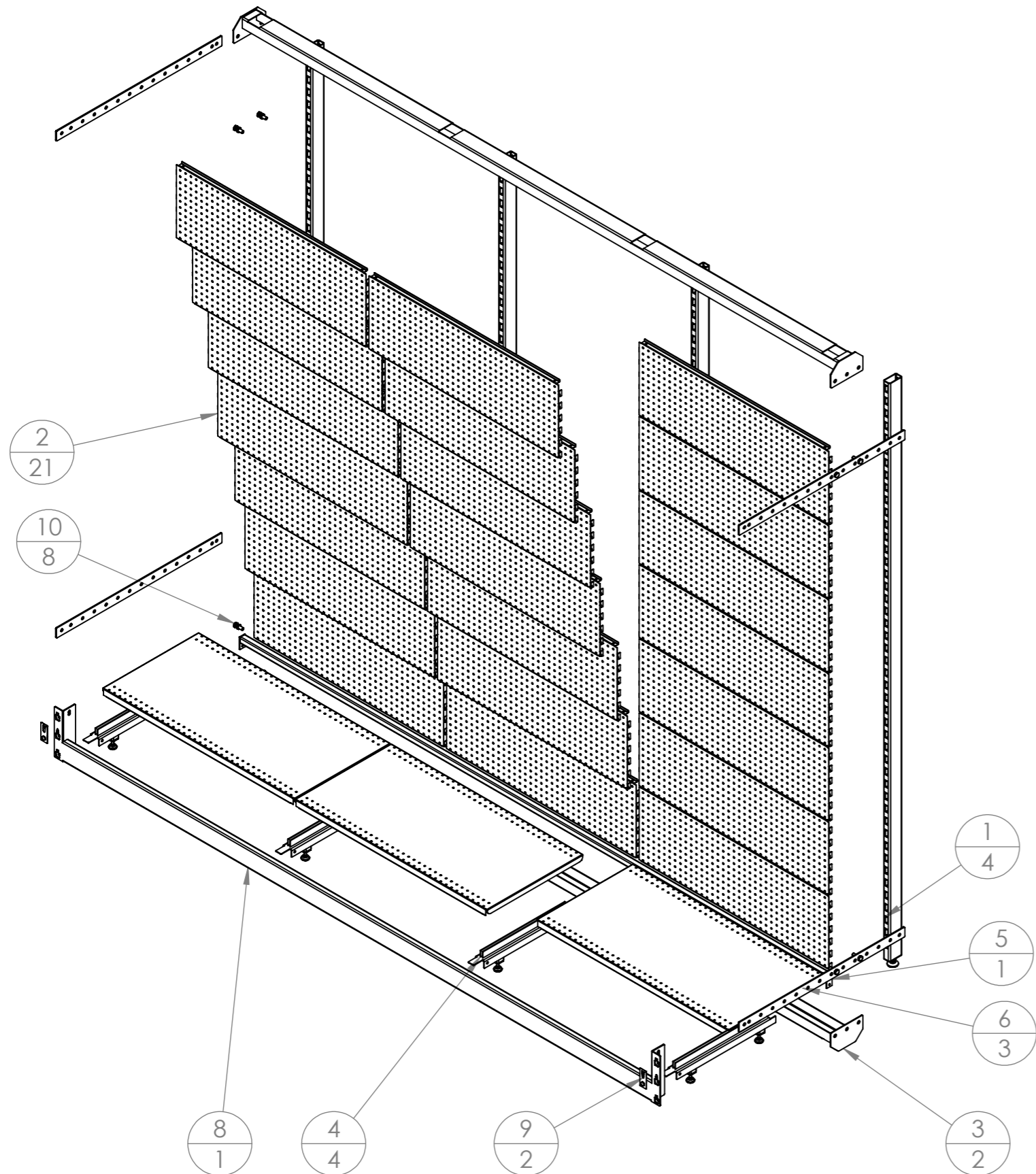

ITEM NO.	PartNo	DESCRIPTION	QTY.
1	RFA2300	2400mm(H) MID PANEL POST	4
2	RFA6124	900mm(W) x 300mm(H) CLIP IN PANEL	21
3	RFA6121	2800mm(W) MID PANEL CHANNEL	2
4	RFA6125	450mm(D) STRUT BAR	4
5	RFA6132	2760mm(W) DROP IN BACK BAR	1
6	RFA6127	900mm(W) x 450mm(D) STEEL SHELF	3
7	RFA6117	838mm(W) ADJUSTABLE HOLE BAR	4
8	RFA6035	2760mm(W) x 80mm(H) STEP BEAM REVERSE LUG	1
9	RFA6036	SAFETY PIN	2
10	RFA6116	M10x30mm NUT AND BOLT SET	8

Rev	Date	Description

ALL DIMENSIONS IN (mm)
 UNLESS OTHERWISE SPECIFIED
 BREAK ALL SHARP EDGES

TOLERANCES
 (BEFORE PAINTING
 & AFTER PLATING)
 X ± 1.00
 X.X ± 0.50
 X.XX ± 0.10
 ANGLES ± 0.5°

A03- EXPLODED
 CLIENT: RFA
 PROJ. NO.: TBA
 PART NO.: --
 Revision --
 Page 3

2760mm(W) x 838mm(D) - 450 MID PANEL SET		
- PRODUCT CODE: RFA6056		
Date:	28/09/2023	DO NOT SCALE Scale@A3 1:20
Drawn by	PS	
Checked by	--	