



FINISH: P/C PEARL WHITE

**AP ASSOCIATED PROJECTS** COMMERCIAL BUILDERS,  
PROJECT MANAGERS,  
PLANNERS & DESIGNERS

T 03 8787 3000 F 03 8787 3025  
48-58 Cyber Loop, Dandenong South VIC 3175

Rev	Date	Description

ALL DIMENSIONS IN (mm)  
UNLESS OTHERWISE SPECIFIED  
BREAK ALL SHARP EDGES

TOLERANCES  
(BEFORE PAINTING  
& AFTER PLATING)  
X ± 1.00  
X.X ± 0.50  
X.XX ± 0.10  
ANGLES ± 0.5°

A01- RENDER  
CLIENT: RFA  
PROJ. NO.: TBA  
PART NO.: --  
Revision --  
Page 1

CLOTHES HANGING RAIL W900 x D300 -		
PRODUCT CODE: -		
Date:	13/06/2024	DO NOT SCALE
Drawn by	PS	
Checked by	--	Scale@A3 1:10

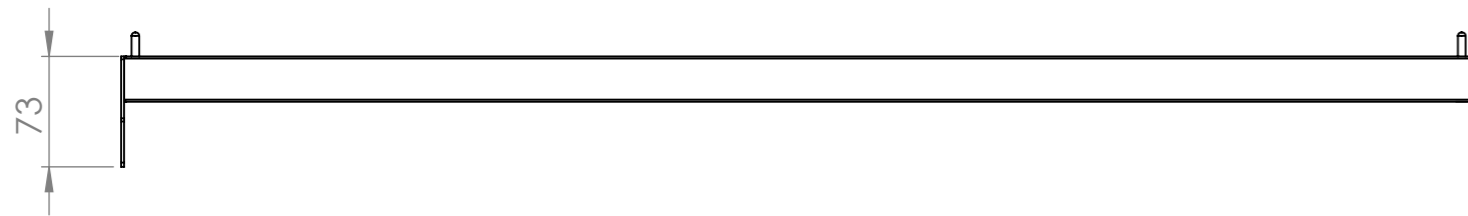
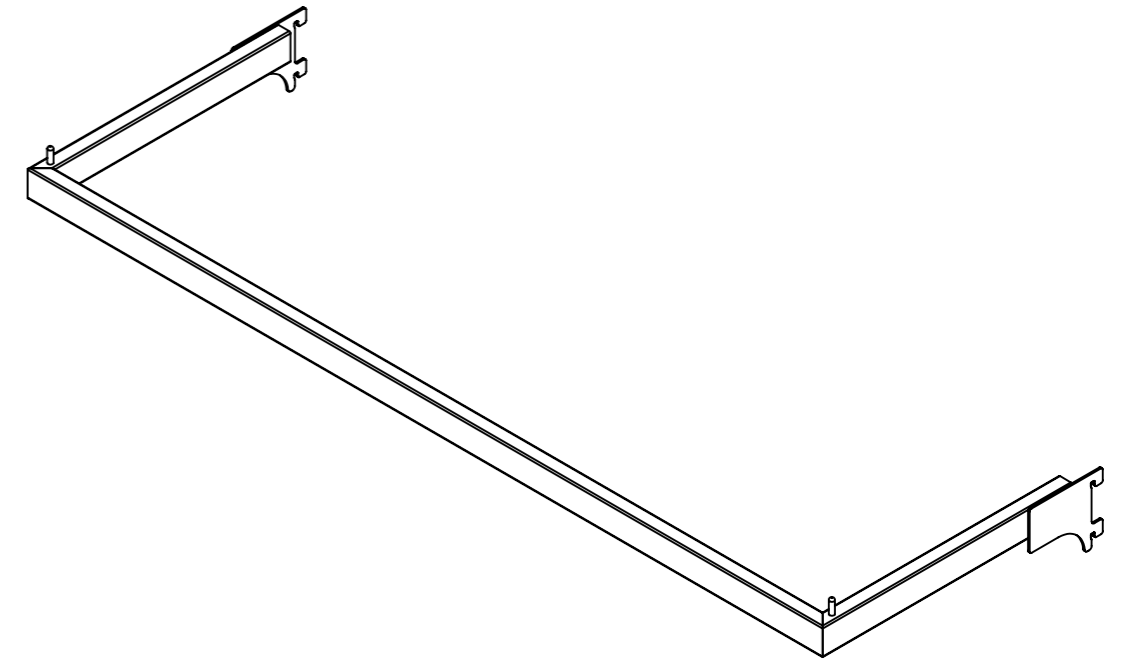
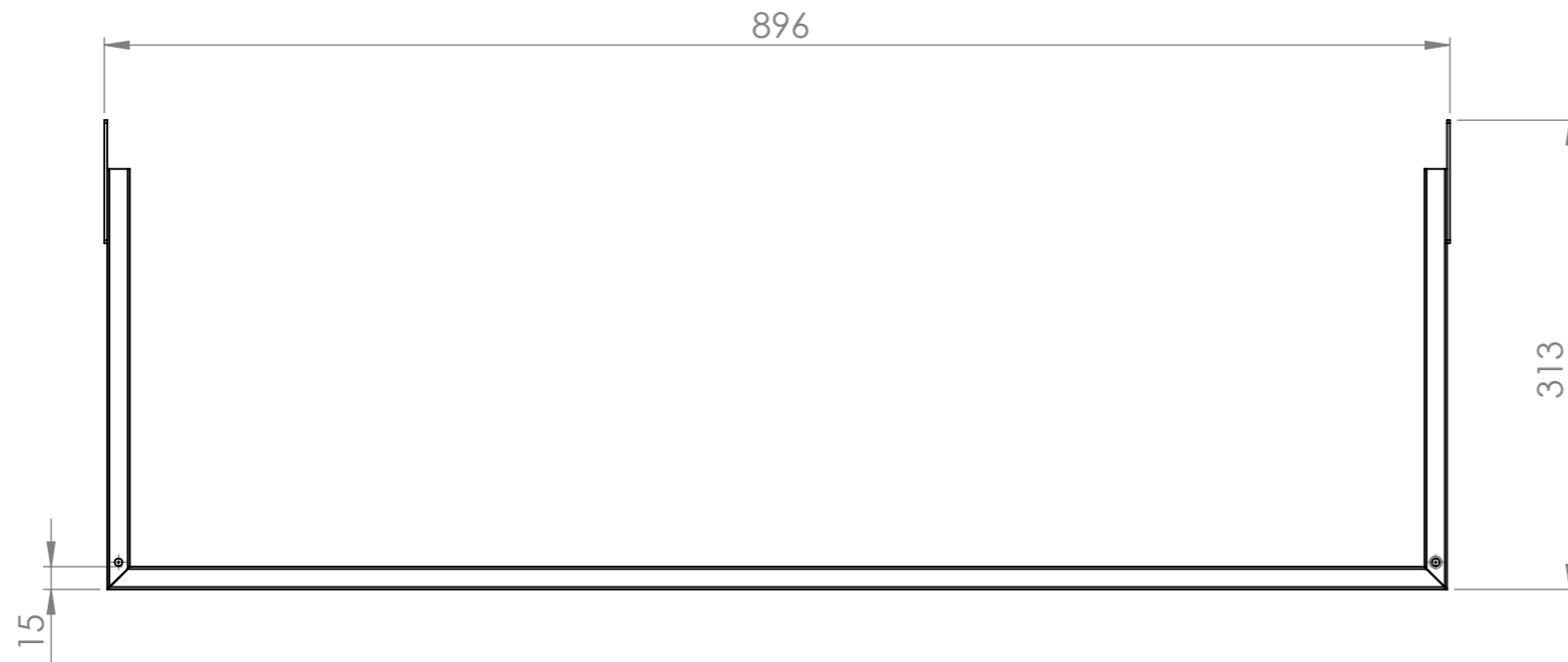

Rev	Date	Description

ALL DIMENSIONS IN (mm)  
UNLESS OTHERWISE SPECIFIED  
BREAK ALL SHARP EDGES

TOLERANCES  
(BEFORE PAINTING  
& AFTER PLATING)  
X ± 1.00  
X.X ± 0.50  
X.XX ± 0.10  
ANGLES ± 0.5°

**A02- DIMENSIONS**

CLIENT: RFA  
PROJ. NO.: TBA  
PART NO.: --  
Revision --  
Page 2

**CLOTHES HANGING RAIL**  
W900 x D300

PRODUCT CODE: -  
Date: 13/06/2024  
Drawn by PS  
Checked by --

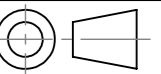
  
DO NOT SCALE  
Scale@A3 1:5

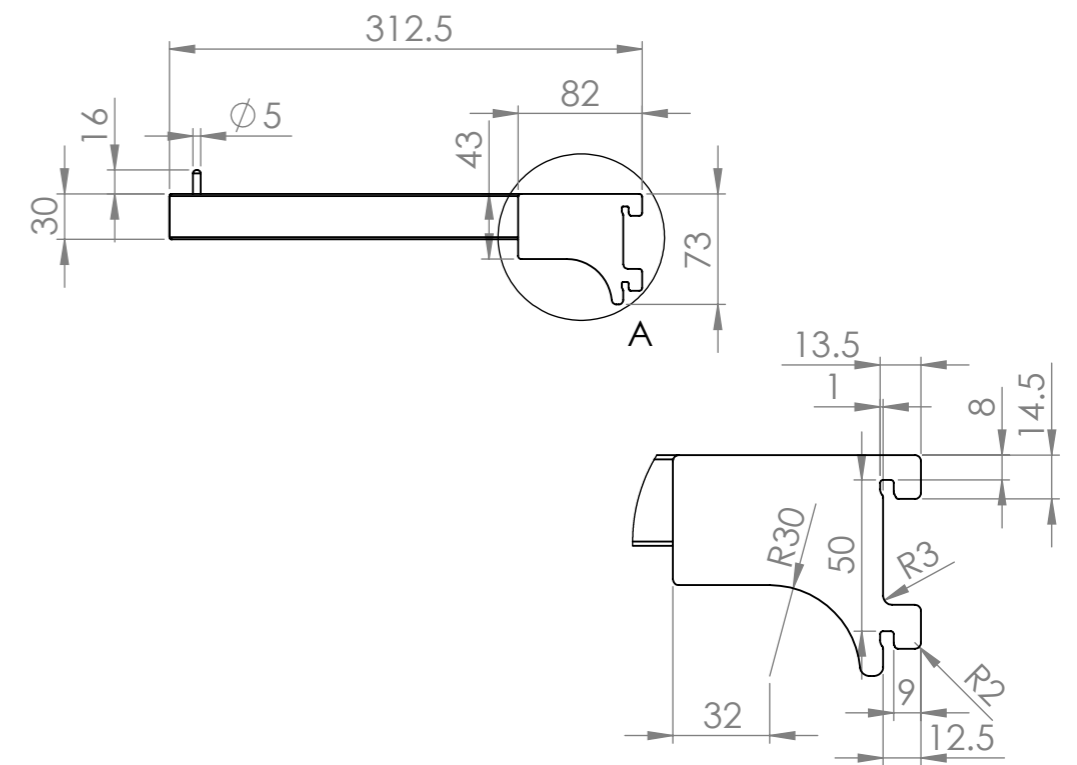
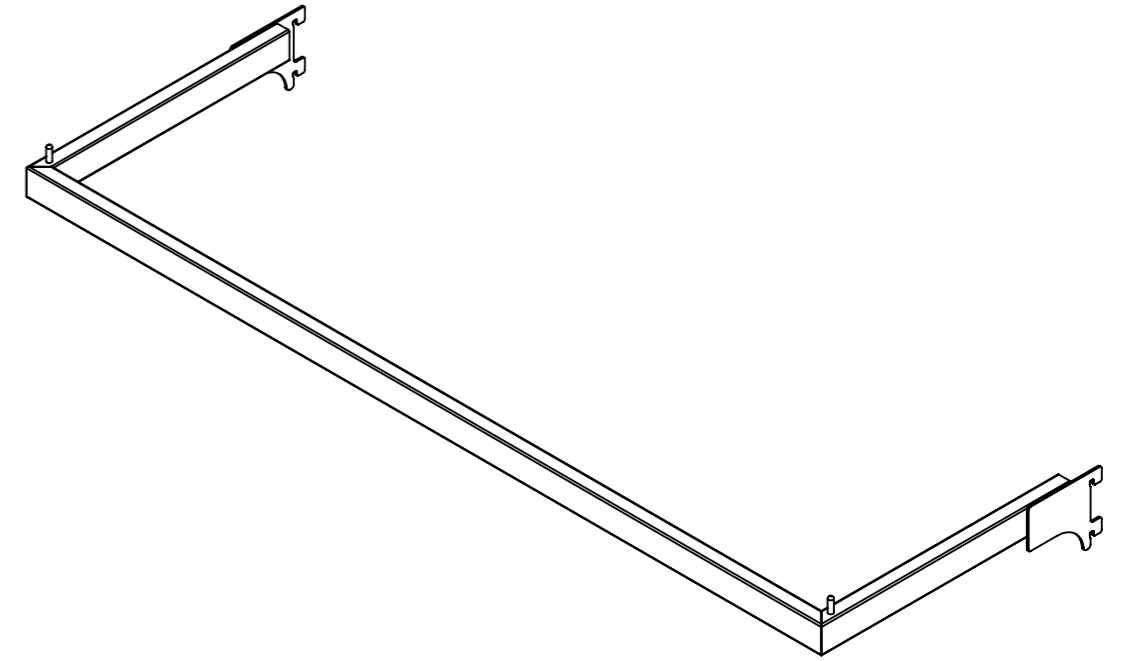
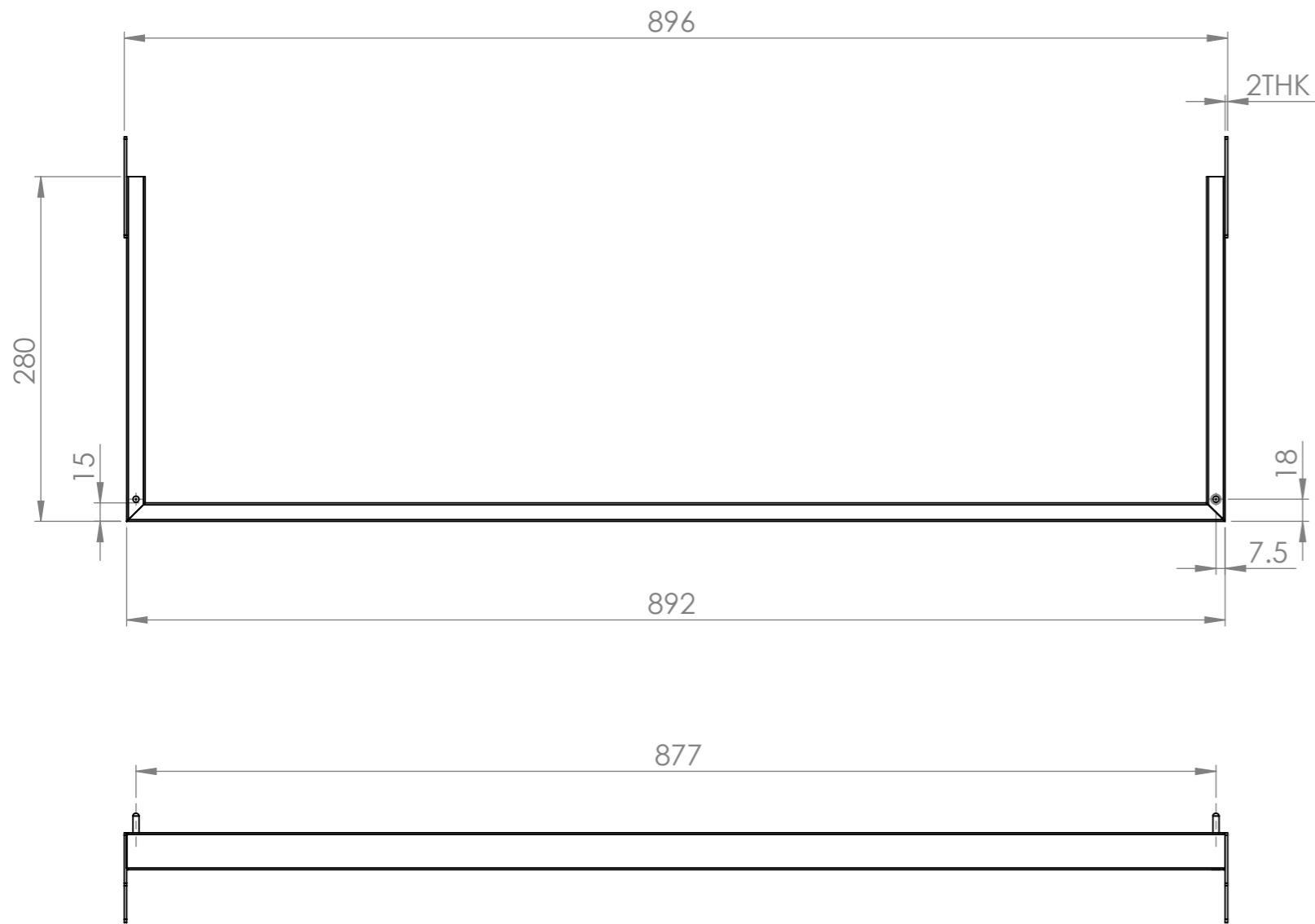

DETAIL A  
SCALE 2 : 5

Rev	Date	Description

ALL DIMENSIONS IN (mm)  
UNLESS OTHERWISE SPECIFIED  
BREAK ALL SHARP EDGES

TOLERANCES  
(BEFORE PAINTING  
& AFTER PLATING)  
X ± 1.00  
X.X ± 0.50  
X.XX ± 0.10  
ANGLES ± 0.5°

**A03- MECHANICAL**

CLIENT: RFA  
PROJ. NO.: TBA  
PART NO.: --  
Revision --  
Page 3

**CLOTHES HANGING RAIL**  
W900 x D300

PRODUCT CODE: -

Date: 13/06/2024

Drawn by PS

Checked by --

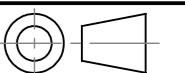

DO NOT SCALE

Scale@A3 1:5