



FINISH: MATTE BLACK



T 03 8787 3000 F 03 8787 3025  
48-58 Cyber Loop, Dandenong South  
VIC 3175 (AUSTRALIA)

© COPYRIGHT. This drawing is the exclusive property of Associated Projects Pty Ltd. It is subject to protection and is strictly confidential. Reproduction in whole or in part is prohibited without obtaining prior permission in writing from the proprietor.

| Rev | Date | Description |
|-----|------|-------------|
|     |      |             |
|     |      |             |
|     |      |             |
|     |      |             |

ALL DIMENSIONS IN (mm)  
UNLESS OTHERWISE SPECIFIED  
BREAK ALL SHARP EDGES

TOLERANCES  
(BEFORE PAINTING  
& AFTER PLATING)  
X ± 1.00  
X.X ± 0.50  
X.XX ± 0.10  
ANGLES ± 0.5°

A01- RENDER  
CLIENT: -  
PROJ. NO.: TBA  
FINISH: P/C MATTE BLACK  
MAT'L: MILD STEEL  
Page 1

CLIP IN PANEL - W900XH150 - SLAT WALL

|                              |           |              |
|------------------------------|-----------|--------------|
| -                            |           |              |
| PRODUCT CODE: <b>RFA2319</b> |           |              |
| Date:                        | 5/10/2023 | DO NOT SCALE |
| Drawn by                     | DH        |              |
| Checked by                   | NP        |              |
| Scale@A3                     |           | 1:1          |

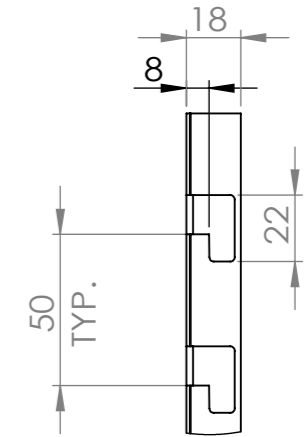
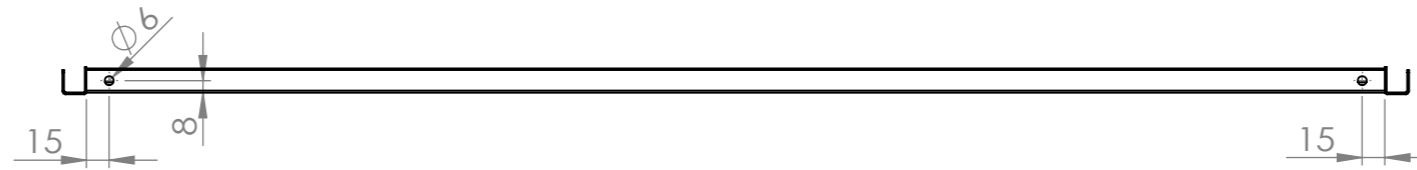
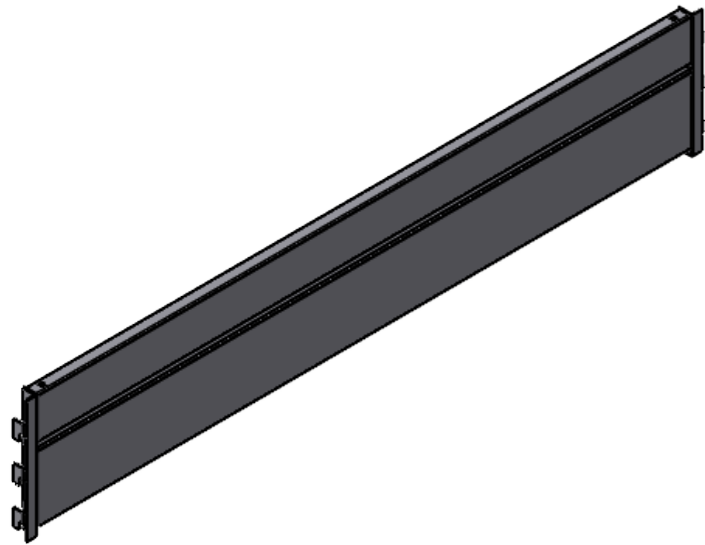

DETAIL R  
SCALE 2 : 5

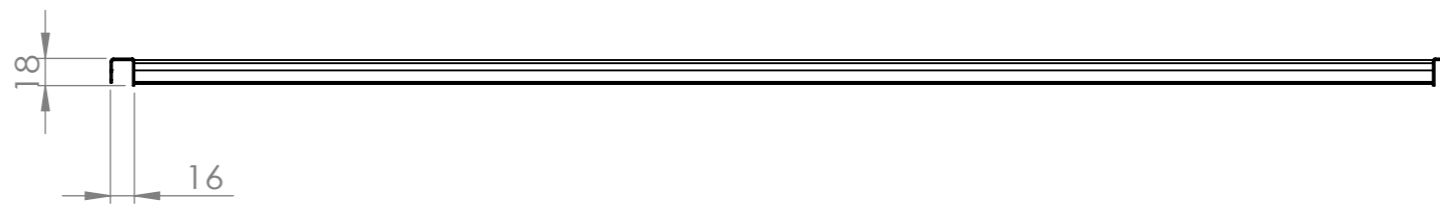
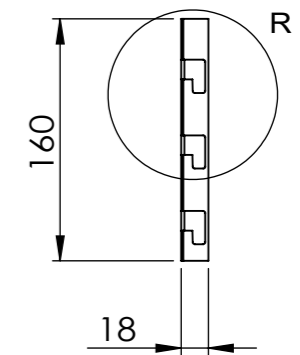
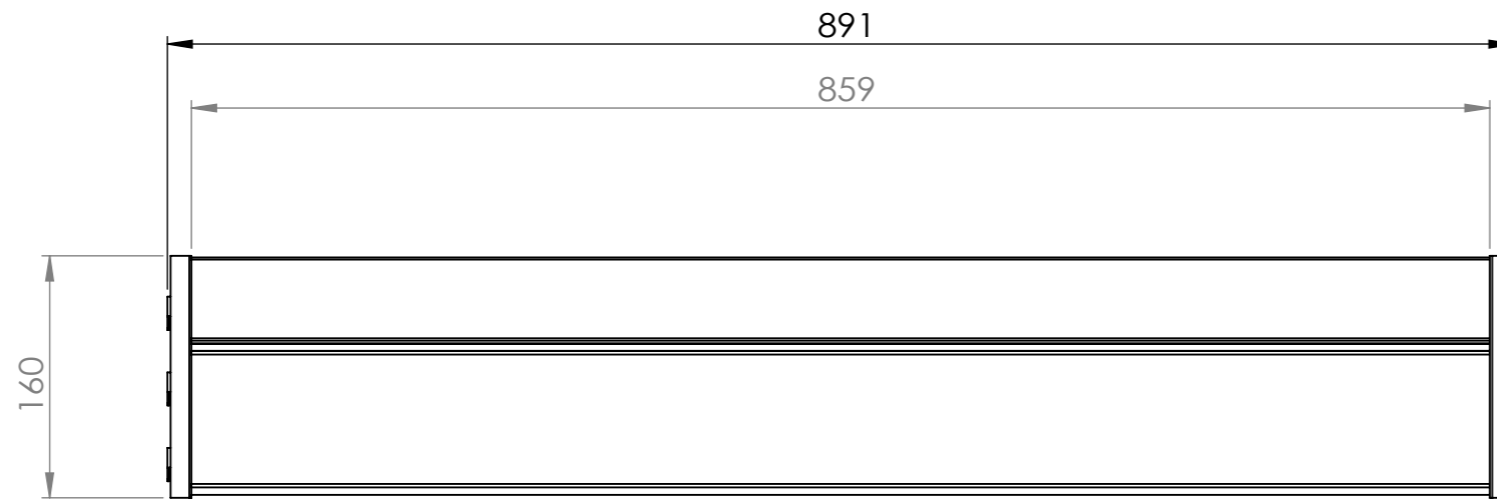

T 03 8787 3000 F 03 8787 3025  
48-58 Cyber Loop, Dandenong South  
VIC 3175 (AUSTRALIA)

© COPYRIGHT. This drawing is the exclusive property of Associated Projects Pty Ltd. It is subject to protection and is strictly confidential. Reproduction in whole or in part is prohibited without obtaining prior permission in writing from the proprietor.

| Rev | Date | Description |
|-----|------|-------------|
|     |      |             |
|     |      |             |
|     |      |             |

ALL DIMENSIONS IN (mm)  
UNLESS OTHERWISE SPECIFIED  
BREAK ALL SHARP EDGES

TOLERANCES  
(BEFORE PAINTING  
& AFTER PLATING)  
X ± 1.00  
X.X ± 0.50  
X.XX ± 0.10  
ANGLES ± 0.5°

A02- CLIENT  
CLIENT: -  
PROJ. NO.: TBA  
FINISH: P/C MATTE BLACK  
MAT'L: MILD STEEL  
Page 2

CLIP IN PANEL - W900XH150 - SLAT WALL

PRODUCT CODE: **RFA2319**

Date: 5/10/2023

Drawn by DH

Checked by NP

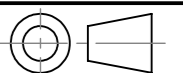

DO NOT SCALE

Scale@A3 1:5