

FINISH: P/C MATTE BLACK

Rev	Date	Description

ALL DIMENSIONS IN (mm)
UNLESS OTHERWISE SPECIFIED
BREAK ALL SHARP EDGES

TOLERANCES
(BEFORE PAINTING
& AFTER PLATING)
X ± 1.00
X.X ± 0.50
X.XX ± 0.10
ANGLES ± 0.5°

A01- RENDER
CLIENT: RFA
PROJ. NO.: TBA
PART NO.: --
Revision --
Page 1

START BAY - WALL BAY - MODULAR - SLAT WALL W900 x H2400		
-		
PRODUCT CODE: RFA2192		DO NOT SCALE
Date:	12/07/2024	
Drawn by	PS	
Checked by	--	
Scale@A3		1:20

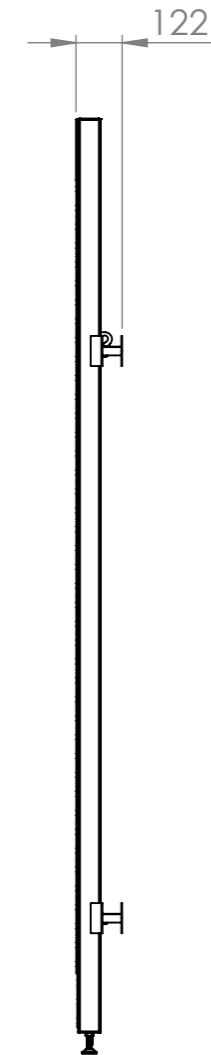
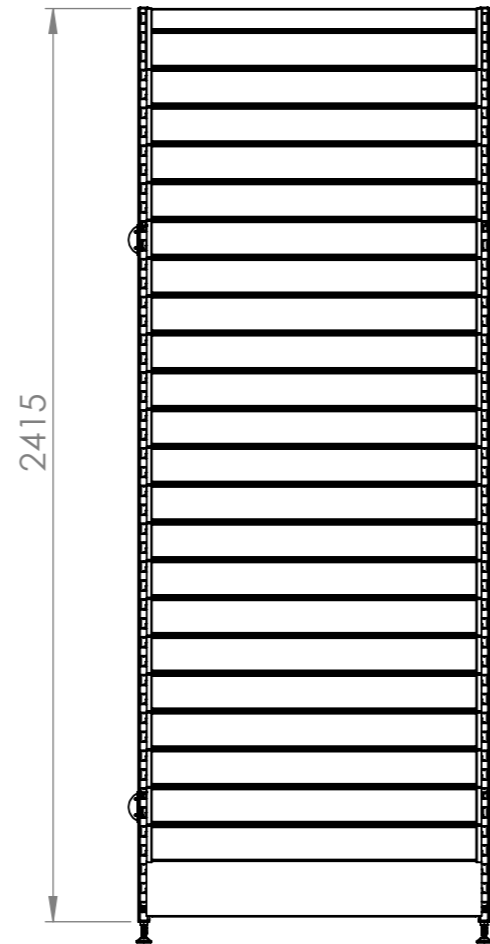
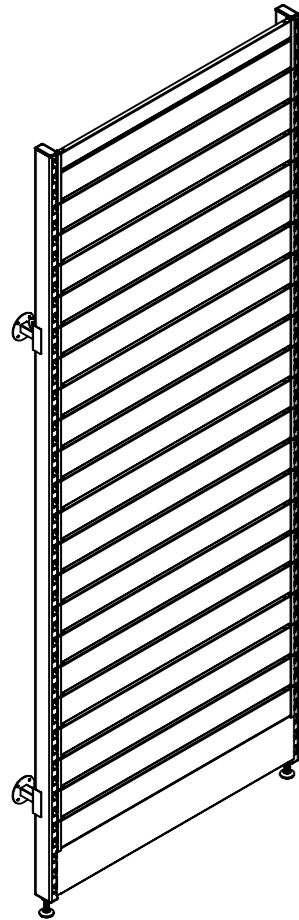

Rev	Date	Description

ALL DIMENSIONS IN (mm)
UNLESS OTHERWISE SPECIFIED
BREAK ALL SHARP EDGES

TOLERANCES
(BEFORE PAINTING
& AFTER PLATING)
X ± 1.00
X.X ± 0.50
X.XX ± 0.10
ANGLES ± 0.5°

A02- DIMENSIONS
CLIENT: RFA
PROJ. NO.: TBA
PART NO.: --
Revision --
Page 2

START BAY - WALL BAY - MODULAR - SLAT WALL W900 x H2400		
- PRODUCT CODE: RFA2192		
Date:	12/07/2024	
Drawn by	PS	
Checked by	--	
		DO NOT SCALE
		Scale@A3 1:20

ITEM NO.	PartNo	DESCRIPTION	QTY.
1	RFA2300	2400mm(H) MID PANEL POST	2
2	RFA2301	POST SUPPORT BRACKET D50-90	4
3	RFA2316	CLIP IN PANEL-W900xH100-SLAT PANEL	21
4	RFA2319	900mm(W)x150mm(H) SLAT PANEL	1
5	RFA2322	W900 X H150 SKIRT	1
6		SAFETY LOCK IN POST CLIP	2

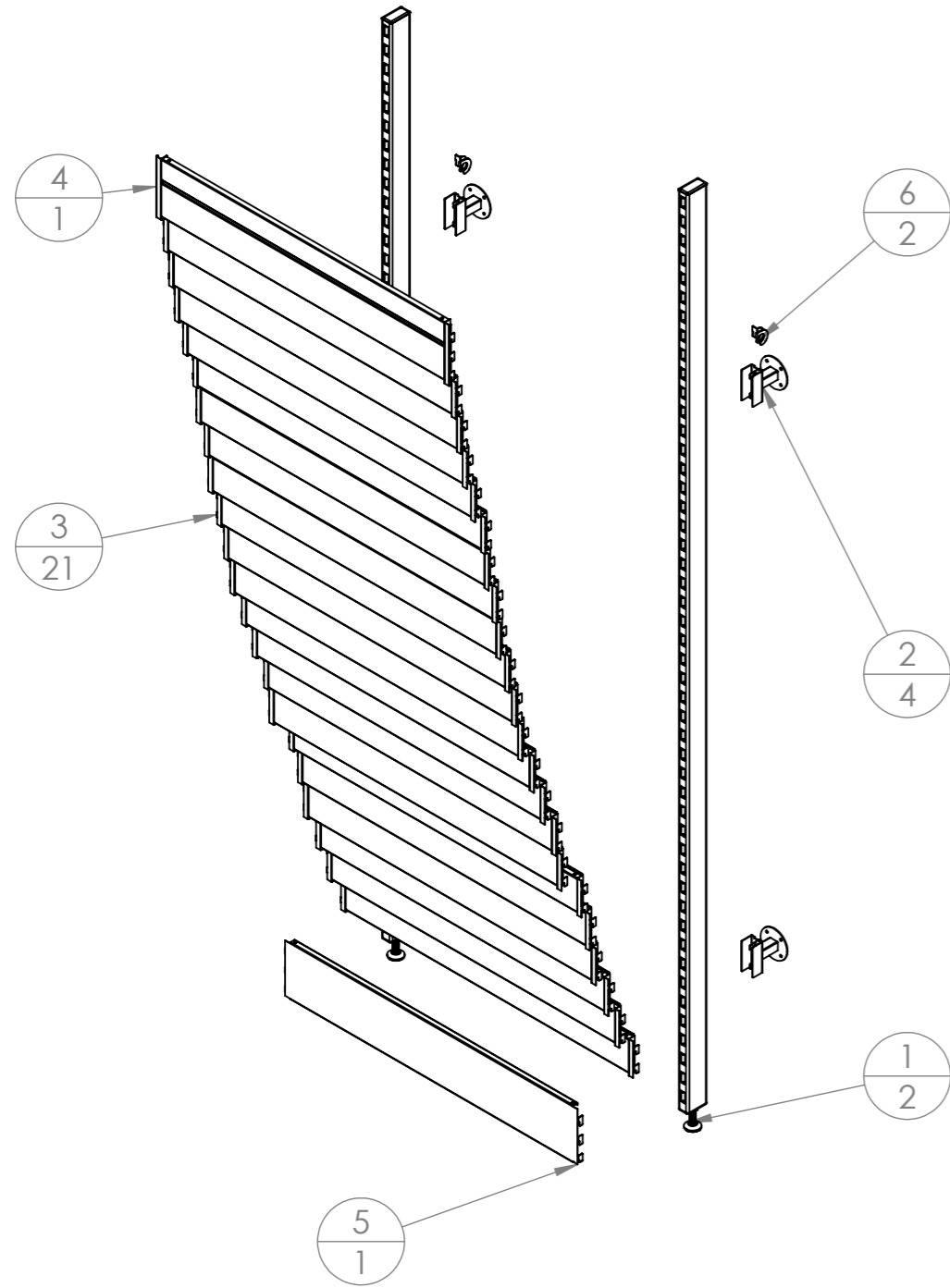

Rev	Date	Description

ALL DIMENSIONS IN (mm)
UNLESS OTHERWISE SPECIFIED
BREAK ALL SHARP EDGES

TOLERANCES
(BEFORE PAINTING
& AFTER PLATING)
X ± 1.00
X.X ± 0.50
X.XX ± 0.10
ANGLES ± 0.5°

A03- EXPLODED
CLIENT: RFA
PROJ. NO.: TBA
PART NO.: --
Revision --
Page 3

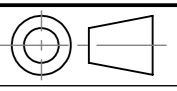
START BAY - WALL BAY - MODULAR - SLAT WALL W900 x H2400		 DO NOT SCALE
PRODUCT CODE: RFA2192	Date: 12/07/2024	
Drawn by PS	Checked by --	Scale@A3 1:20