



FINISH: P/C MATTE BLACK

AP ASSOCIATED PROJECTS COMMERCIAL BUILDERS,
PROJECT MANAGERS,
PLANNERS & DESIGNERS

T 03 8787 3000 F 03 8787 3025
48-58 Cyber Loop, Dandenong South VIC 3175

Rev	Date	Description

ALL DIMENSIONS IN (mm)
UNLESS OTHERWISE SPECIFIED
BREAK ALL SHARP EDGES

TOLERANCES
(BEFORE PAINTING
& AFTER PLATING)
X ± 1.00
X.X ± 0.50
X.XX ± 0.10
ANGLES ± 0.5°

A01- RENDER

CLIENT: RFA

PROJ. NO.: TBA

PART NO.: --

Revision --

Page 1

START BAY - WALL BAY _ MODULAR - SLAT WALL
W600 x H2400

PRODUCT CODE: **RFA2190**

Date: 12/07/2024

Drawn by PS

Checked by --

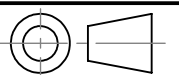

DO NOT SCALE

Scale@A3 1:20

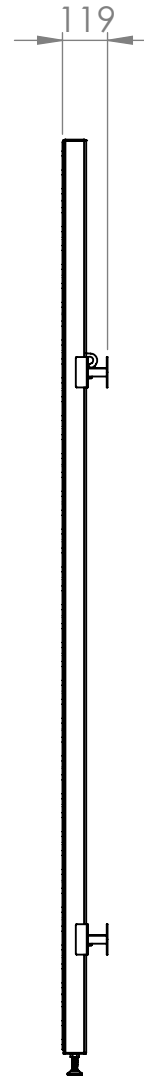
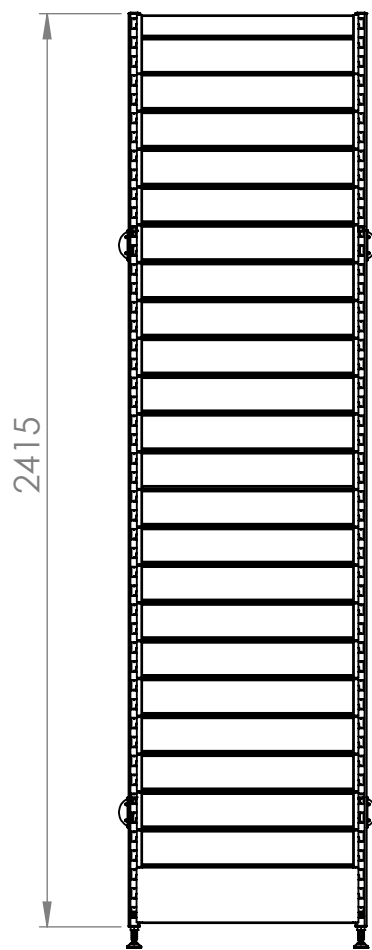
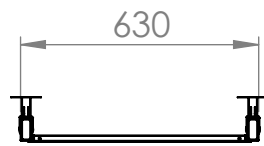
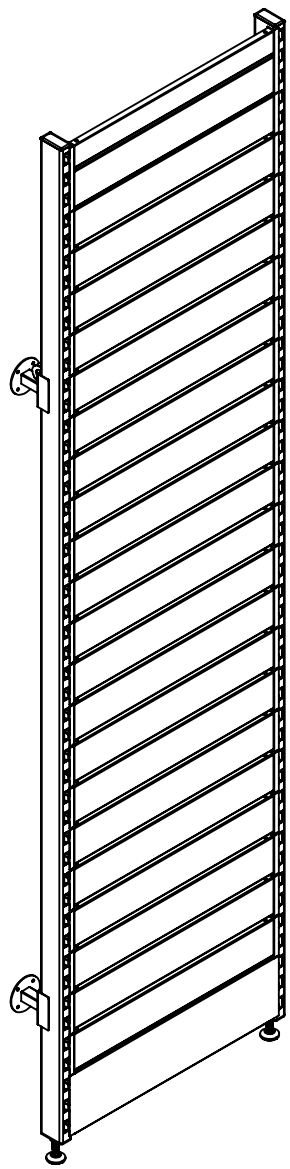

Rev	Date	Description

ALL DIMENSIONS IN (mm)
UNLESS OTHERWISE SPECIFIED
BREAK ALL SHARP EDGES

TOLERANCES
(BEFORE PAINTING
& AFTER PLATING)
X ± 1.00
X.X ± 0.50
X.XX ± 0.10
ANGLES ± 0.5°

A02- DIMENSIONS
CLIENT: RFA
PROJ. NO.: TBA
PART NO.: --
Revision --
Page 2

START BAY - WALL BAY _ MODULAR - SLAT WALL W600 x H2400		
PRODUCT CODE: RFA2190	Date: 12/07/2024	
Drawn by PS	Checked by --	DO NOT SCALE
		Scale@A3 1:20

ITEM NO.	PartNo	DESCRIPTION	QTY.
1	RFA2300	2400mm(H) MID PANEL POST	2
2	RFA2301	POST SUPPORT BRACKET D50-90	4
3		SAFETY LOCK IN POST CLIP	2
4	RFA2315	CLIP IN PANEL - W600XH100 - SLAT WALL	21
5	RFA2318	CLIP IN PANEL-W600xH150- SLAT PANEL	1
6	RFA2321	W600 X H150 SKIRT	1

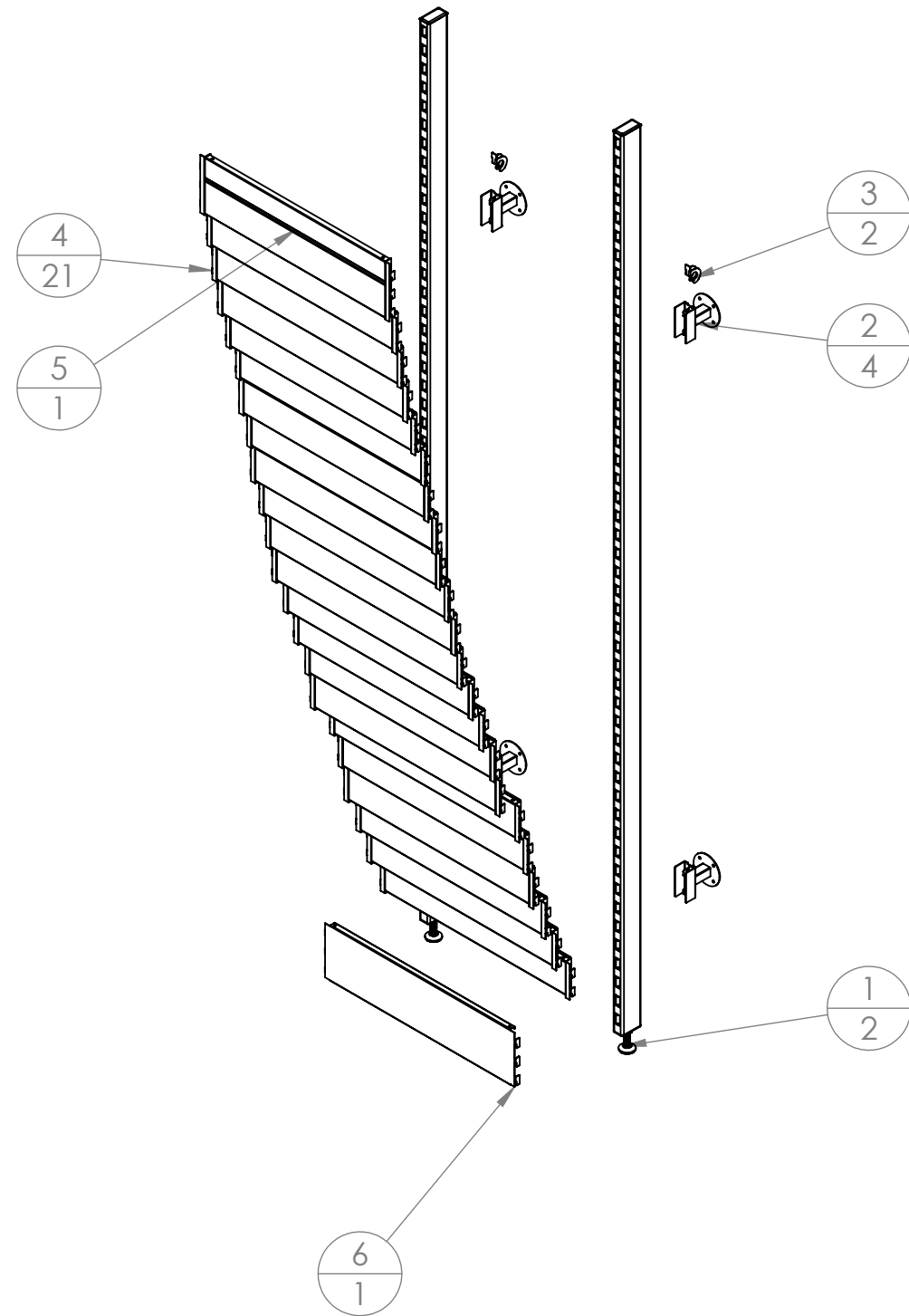

Rev	Date	Description

ALL DIMENSIONS IN (mm)
UNLESS OTHERWISE SPECIFIED
BREAK ALL SHARP EDGES

TOLERANCES
(BEFORE PAINTING
& AFTER PLATING)
X ± 1.00
X.X ± 0.50
X.XX ± 0.10
ANGLES ± 0.5°

A03- CLIENT
CLIENT: RFA
PROJ. NO.: TBA
PART NO.: --
Revision --
Page 3

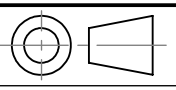
START BAY - WALL BAY - MODULAR - SLAT WALL W600 x H2400		 DO NOT SCALE
PRODUCT CODE: RFA2190	Date: 12/07/2024	
Drawn by PS	Checked by --	Scale@A3 1:20