

FINISH: P/C MATTE BLACK

AP ASSOCIATED PROJECTS COMMERCIAL BUILDERS,
PROJECT MANAGERS,
PLANNERS & DESIGNERS

T 03 8787 3000 F 03 8787 3025
48-58 Cyber Loop, Dandenong South VIC 3175

Rev	Date	Description

ALL DIMENSIONS IN (mm)
UNLESS OTHERWISE SPECIFIED
BREAK ALL SHARP EDGES

TOLERANCES
(BEFORE PAINTING
& AFTER PLATING)
X ± 1.00
X.X ± 0.50
X.XX ± 0.10
ANGLES ± 0.5°

A01- RENDER

CLIENT: RFA

PROJ. NO.: TBA

PART NO.: --

Revision --

Page 1

START BAY - WALL BAY _ MODULAR - NON PERF
W600 x H2400

PRODUCT CODE: RFA2184

Date: 12/07/2024

Drawn by PS

Checked by --

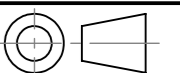

DO NOT SCALE

Scale@A3 1:20

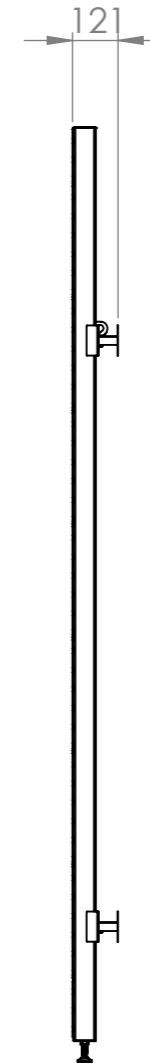
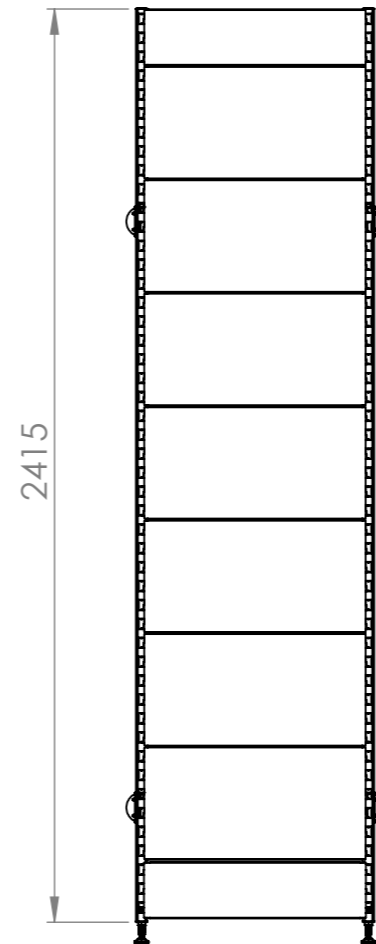
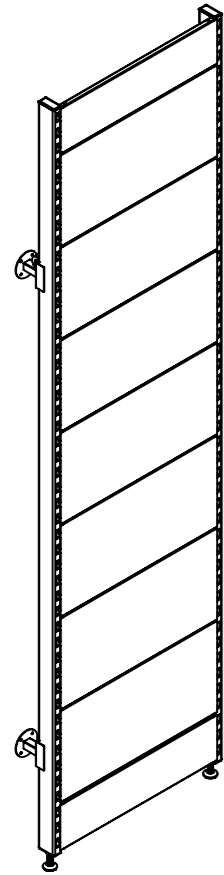

Rev	Date	Description

ALL DIMENSIONS IN (mm)
UNLESS OTHERWISE SPECIFIED
BREAK ALL SHARP EDGES

TOLERANCES
(BEFORE PAINTING
& AFTER PLATING)
X ± 1.00
X.X ± 0.50
X.XX ± 0.10
ANGLES ± 0.5°

A02- DIMENSIONS

CLIENT: RFA
PROJ. NO.: TBA
PART NO.: --
Revision --
Page 2

START BAY - WALL BAY _ MODULAR - NON PERF
W600 x H2400

PRODUCT CODE: **RFA2184**

Date: 12/07/2024

Drawn by PS

Checked by --

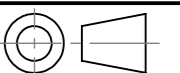

DO NOT SCALE

Scale@A3 1:20

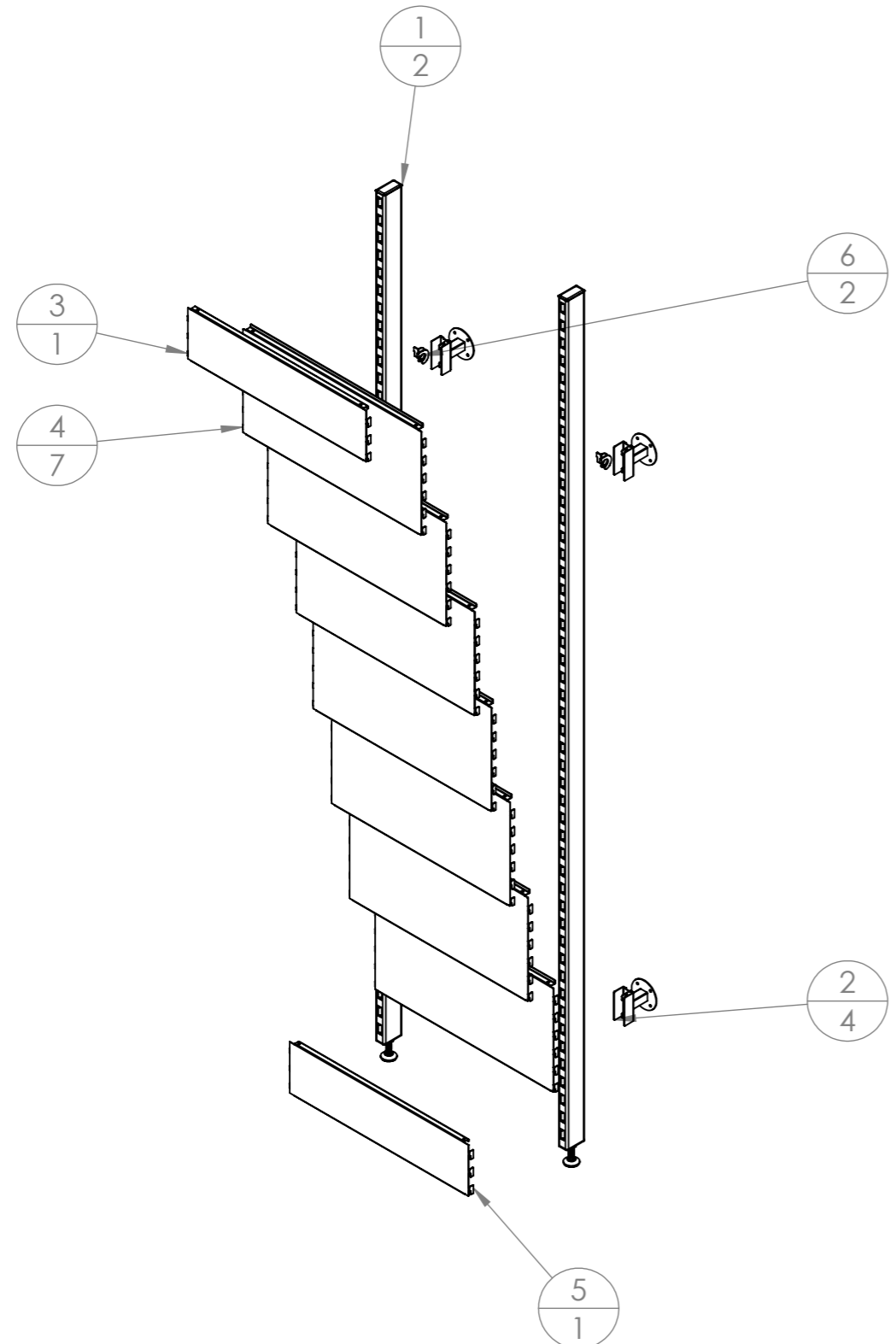

ITEM NO.	PartNo	DESCRIPTION	QTY.
1	RFA2300	2400mm(H) MID PANEL POST	2
2	RFA2301	POST SUPPORT BRACKET D50-90	4
3	RFA2309	W600xH150 NON PERFORATED PANEL	1
4	RFA2312	W600xH300 NON PERFORATED PANEL	7
5	RFA2321	W600 X H150 SKIRT	1
6		SAFETY LOCK IN POST CLIP	2

AP ASSOCIATED PROJECTS COMMERCIAL BUILDERS, PROJECT MANAGERS, PLANNERS & DESIGNERS
 T 03 8787 3000 F 03 8787 3025
 48-58 Cyber Loop, Dandenong South VIC 3175

Rev	Date	Description

ALL DIMENSIONS IN (mm)
 UNLESS OTHERWISE SPECIFIED
 BREAK ALL SHARP EDGES

TOLERANCES
 (BEFORE PAINTING
 & AFTER PLATING)
 X ± 1.00
 X.X ± 0.50
 X.XX ± 0.10
 ANGLES ± 0.5°

A03- EXPLODED
 CLIENT: RFA
 PROJ. NO.: TBA
 PART NO.: --
 Revision --
 Page 3

START BAY - WALL BAY _ MODULAR - NON PERF
 W600 x H2400

PRODUCT CODE: **RFA2184**

Date: 12/07/2024

Drawn by PS

Checked by --

DO NOT SCALE

Scale@A3 1:20