

T 03 8787 3000 F 03 8787 3025
 48-58 Cyber Loop, Dandenong South
 VIC 3175 (AUSTRALIA)

© COPYRIGHT. This drawing is the exclusive property of Associated Projects Pty Ltd. It is subject to protection and is strictly confidential. Reproduction in whole or in part is prohibited without obtaining prior permission in writing from the proprietor.

Rev	Date	Description

ALL DIMENSIONS IN (mm)
 UNLESS OTHERWISE SPECIFIED
 BREAK ALL SHARP EDGES

TOLERANCES
 (BEFORE PAINTING
 & AFTER PLATING)
 X ± 1.00
 X.X ± 0.50
 X.XX ± 0.10
 ANGLES ± 0.5°

A01- RENDER
 CLIENT: -
 PROJ. NO.: TBA
 FINISH: P/C MATTE BLACK
 MAT'L: VARIOUS
 Page 1

START BAY -QUEUE GONDOLA -W1200 H1200 -SLAT PANELS

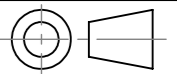
PRODUCT CODE: RFA2128		 DO NOT SCALE
Date:	18/10/2023	
Drawn by	DH	Scale@A3 1:1
Checked by	NP	

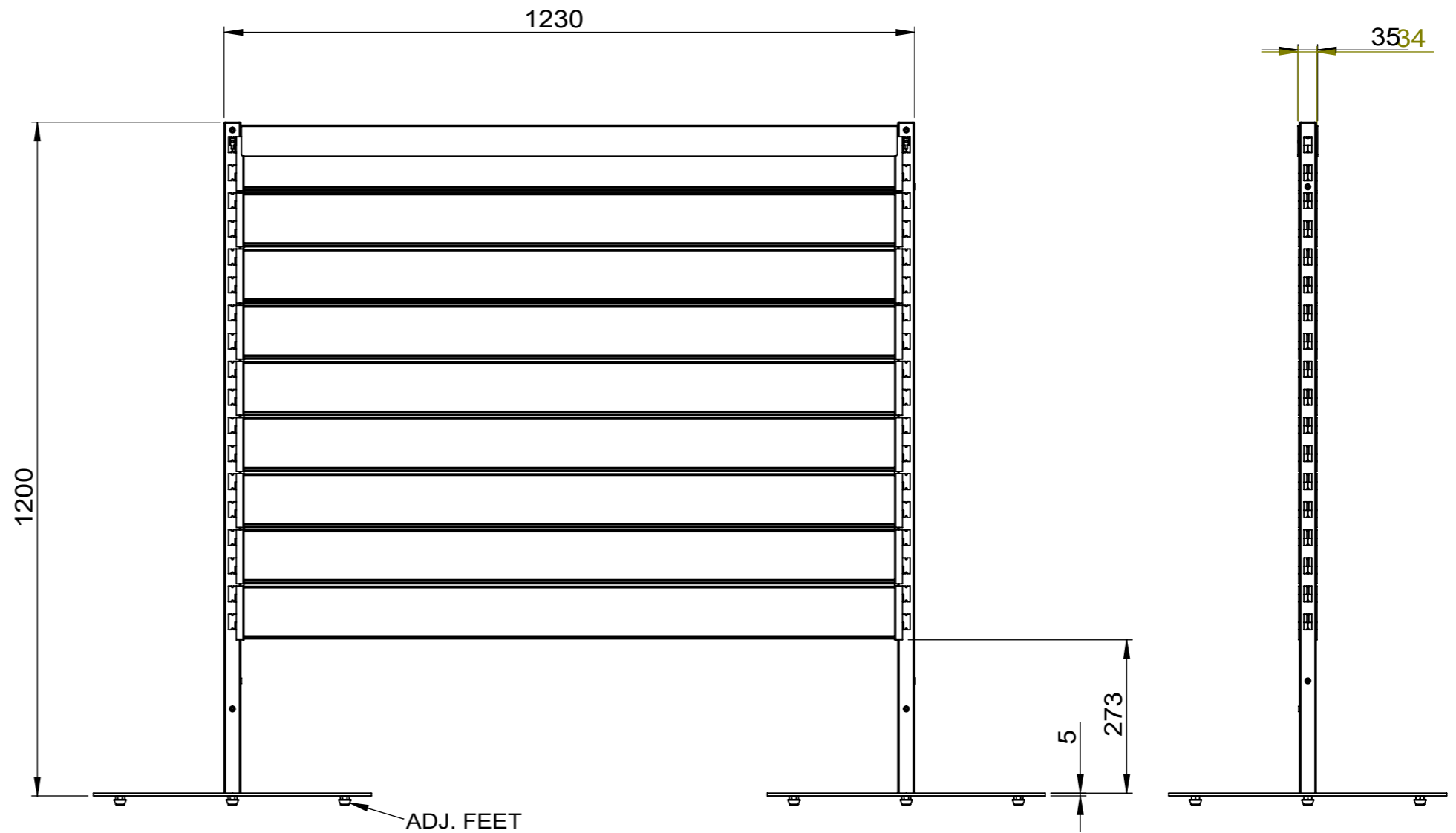
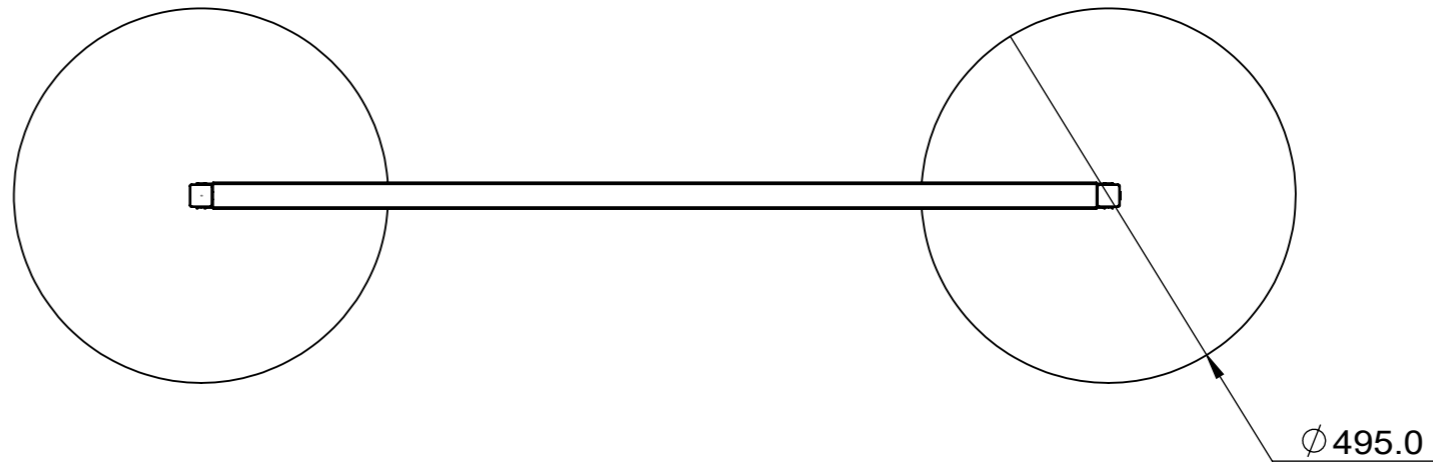
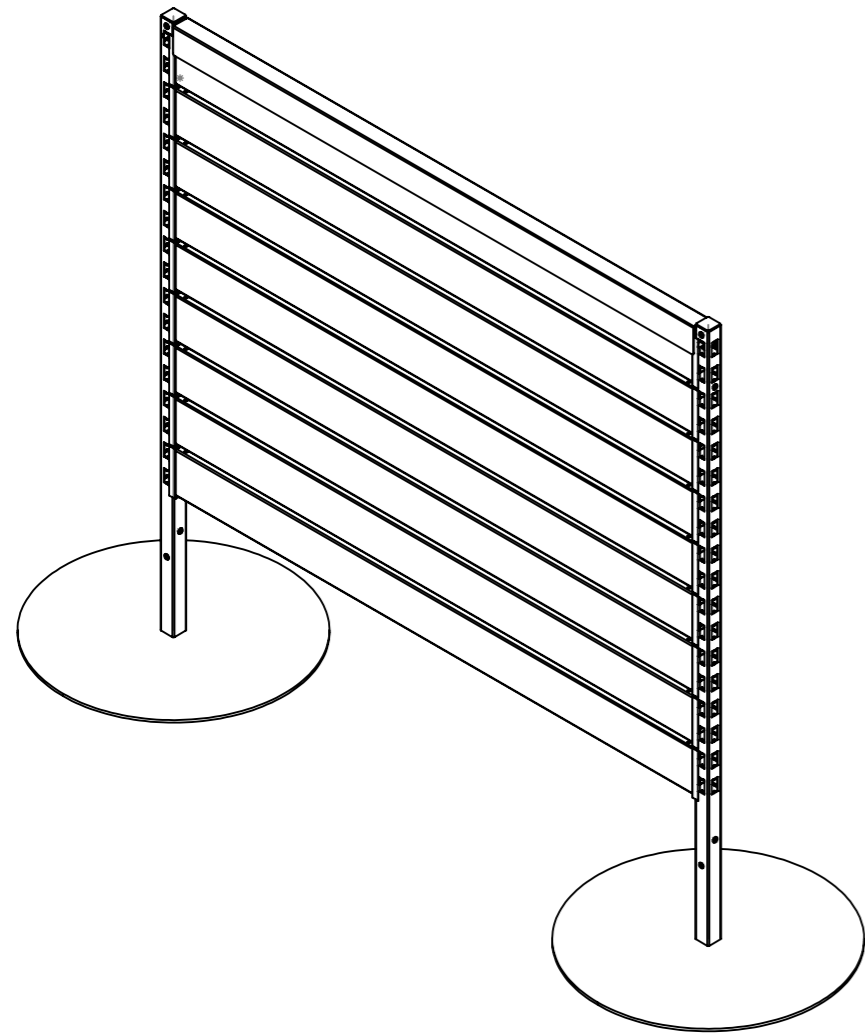

T 03 8787 3000 F 03 8787 3025
 48-58 Cyber Loop, Dandenong South
 VIC 3175 (AUSTRALIA)

© COPYRIGHT. This drawing is the exclusive property of Associated Projects Pty Ltd. It is subject to protection and is strictly confidential. Reproduction in whole or in part is prohibited without obtaining prior permission in writing from the proprietor.

Rev	Date	Description

ALL DIMENSIONS IN (mm)
 UNLESS OTHERWISE SPECIFIED
 BREAK ALL SHARP EDGES

TOLERANCES
 (BEFORE PAINTING
 & AFTER PLATING)
 X ± 1.00
 X.X ± 0.50
 X.XX ± 0.10
 ANGLES ± 0.5°

A02- CLIENT
 CLIENT: -
 PROJ. NO.: TBA
 FINISH: P/C MATTE BLACK
 MAT'L: VARIOUS
 Page 2

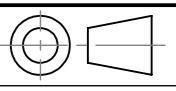
START BAY -QUEUE GONDOLA -W1200 H1200 -SLAT PANELS		 DO NOT SCALE
PRODUCT CODE: RFA2128	Date: 18/10/2023	
Drawn by: DH	Checked by: NP	Scale@A3 1:10

ITEM NO.	PRODUCT CODE	DESCRIPTION	FINISH	QTY.
1	RFA2701	POST - QUEUE GONDOLA	P/C MATTE BLAKC	2
2	RFA2724	QUEUE GONDOLA - TOP CAP	P/C MATTE BLACK	1
3	RFA2317	CLIP IN PANEL - W1200XH100 - SLAT WALL	P/C MATTE BLACK	18
4	-	LOCKING CLLP	SAME AS THE POST	2
5	-	ADJ. FEET, M8 x6mm THD, BASE OD25mm, 5mm THK	RAW	8

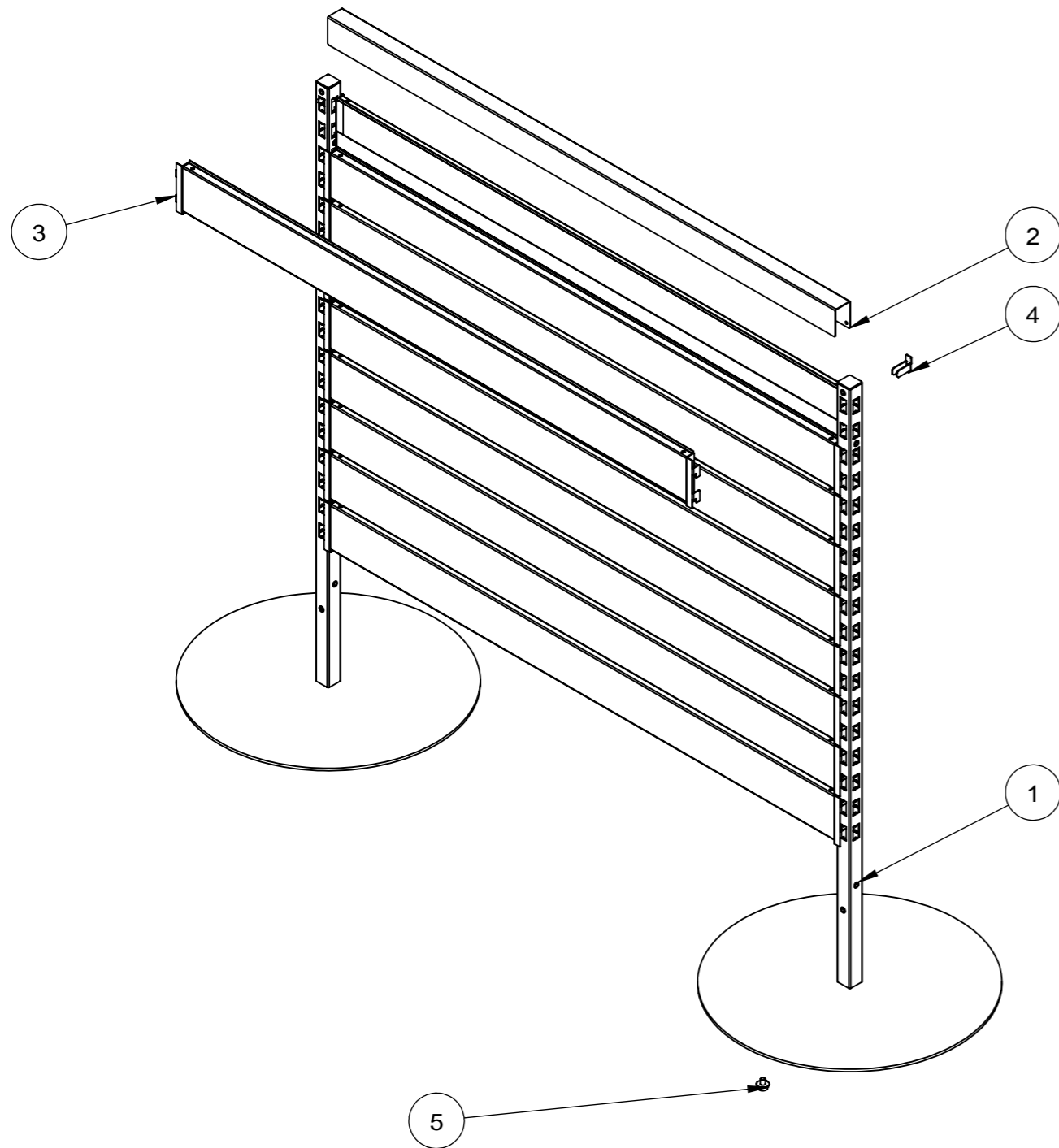

T 03 8787 3000 F 03 8787 3025
48-58 Cyber Loop, Dandenong South
VIC 3175 (AUSTRALIA)

© COPYRIGHT. This drawing is the exclusive property of Associated Projects Pty Ltd. It is subject to protection and is strictly confidential. Reproduction in whole or in part is prohibited without obtaining prior permission in writing from the proprietor.

Rev	Date	Description

ALL DIMENSIONS IN (mm)
UNLESS OTHERWISE SPECIFIED
BREAK ALL SHARP EDGES

TOLERANCES
(BEFORE PAINTING
& AFTER PLATING)
X ± 1.00
X.X ± 0.50
X.XX ± 0.10
ANGLES ± 0.5°

A04- EXPLODED VIEW

CLIENT: -

PROJ. NO.: TBA

FINISH: P/C MATTE BLACK

MAT'L: VARIOUS

Page 4

START BAY -QUEUE GONDOLA -W1200 H1200 -SLAT PANELS

PRODUCT CODE: **RFA2128**

Date: 18/10/2023

Drawn by DH

Checked by NP

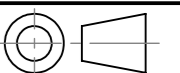

DO NOT SCALE

Scale@A3 1:10