



T 03 8787 3000 F 03 8787 3025
 48-58 Cyber Loop, Dandenong South
 VIC 3175 (AUSTRALIA)

© COPYRIGHT. This drawing is the exclusive property of Associated Projects Pty Ltd. It is subject to protection and is strictly confidential. Reproduction in whole or in part is prohibited without obtaining prior permission in writing from the proprietor.

Rev	Date	Description

ALL DIMENSIONS IN (mm)
 UNLESS OTHERWISE SPECIFIED
 BREAK ALL SHARP EDGES

TOLERANCES
 (BEFORE PAINTING
 & AFTER PLATING)
 X ± 1.00
 X.X ± 0.50
 X.XX ± 0.10
 ANGLES ± 0.5°

A01- RENDER
CLIENT: -
PROJ. NO.: TBA
FINISH: P/C MATTE BLACK
MAT'L: VARIOUS
Page 1

**START BAY -QUEUE GONDOLA -W900 H1200 -
 PREFORATED**

PRODUCT CODE: RFA2118

Date: 18/10/2023

Drawn by DH

Checked by NP

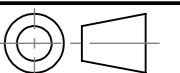

DO NOT SCALE

Scale@A3 1:1

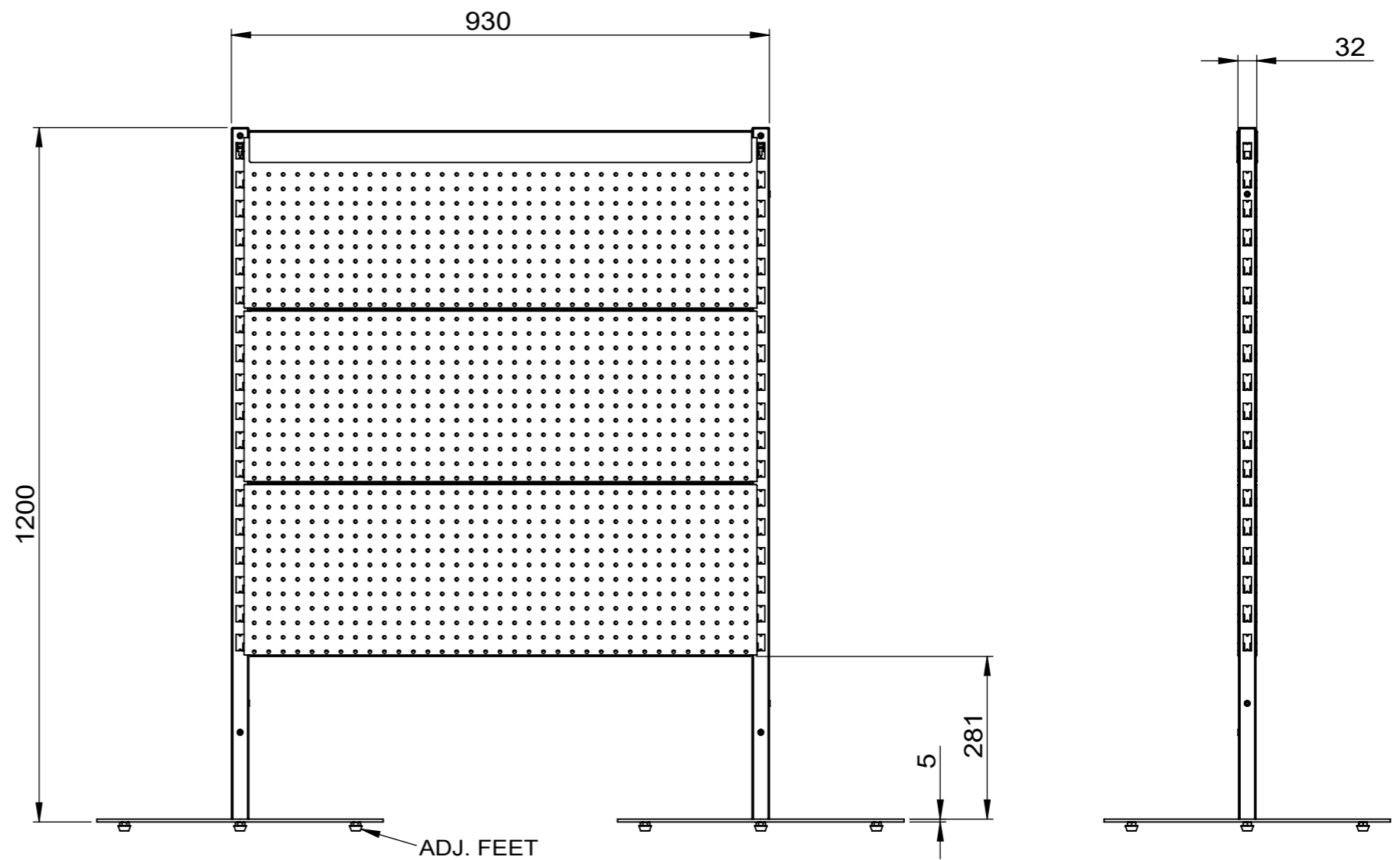
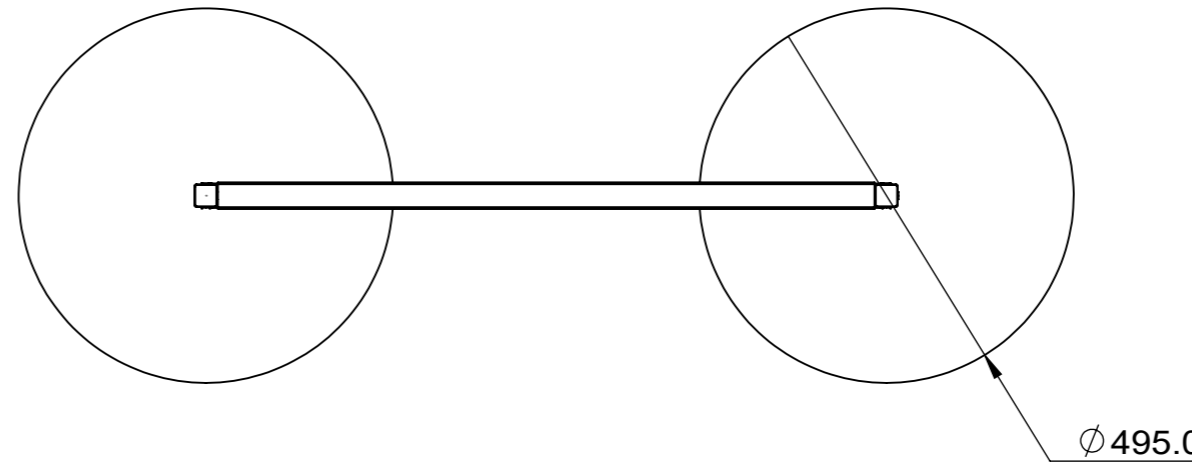
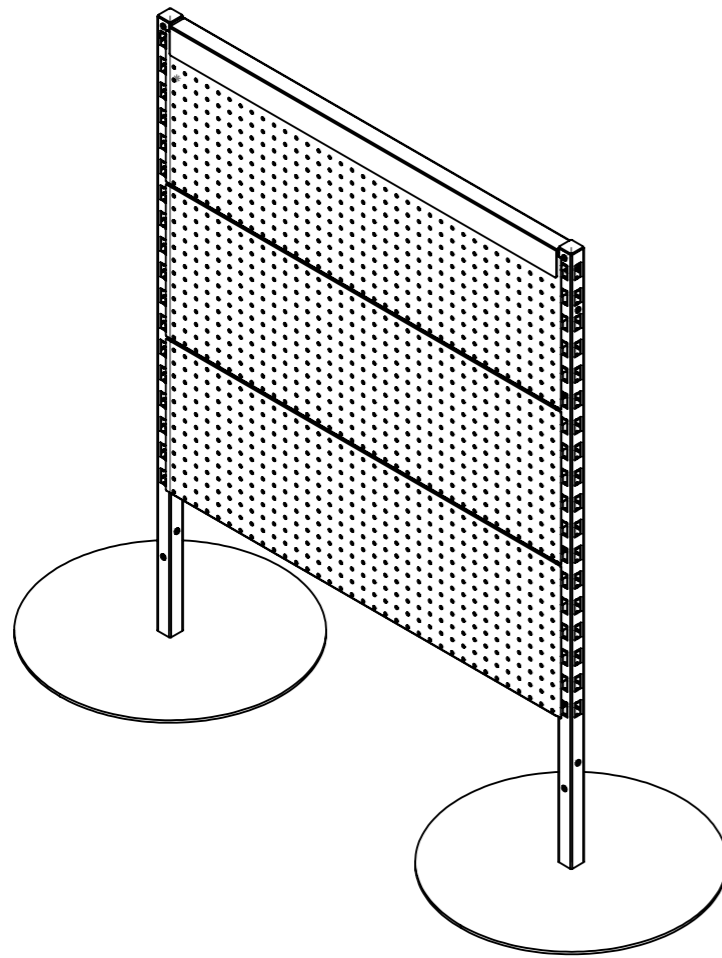

T 03 8787 3000 F 03 8787 3025
48-58 Cyber Loop, Dandenong South
VIC 3175 (AUSTRALIA)

© COPYRIGHT. This drawing is the exclusive property of Associated Projects Pty Ltd. It is subject to protection and is strictly confidential. Reproduction in whole or in part is prohibited without obtaining prior permission in writing from the proprietor.

Rev	Date	Description

ALL DIMENSIONS IN (mm)
UNLESS OTHERWISE SPECIFIED
BREAK ALL SHARP EDGES

TOLERANCES
(BEFORE PAINTING
& AFTER PLATING)
X ± 1.00
X.X ± 0.50
X.XX ± 0.10
ANGLES ± 0.5°

A02- CLIENT

CLIENT: -

PROJ. NO.: TBA

FINISH: P/C MATTE BLACK

MAT'L: VARIOUS

Page 2

START BAY -QUEUE GONDOLA -W900 H1200 -
PREFORATED

PRODUCT CODE: **RFA2118**

Date: 18/10/2023

Drawn by DH

Checked by NP

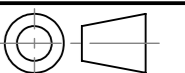

DO NOT SCALE

Scale@A3 1:10

ITEM NO.	PRODUCT CODE	DESCRIPTION	FINISH	QTY.
1	RFA2701	POST - QUEUE GONDOLA	P/C MATTE BLAKC	2
2	RFA2307	CLIP IN PANEL - W900XH300 - PERFORATED	P/C MATTE BLACK	6
3	RFA2722	QUEUE GONDOLA - TOP CAP	P/C MATTE BLACK	1
4	-	LOCKING CLLP	SAME AS THE POST	2
5	-	ADJ. FEET, M8 x6mm THD, BASE OD25mm, 5mm THK	RAW	8

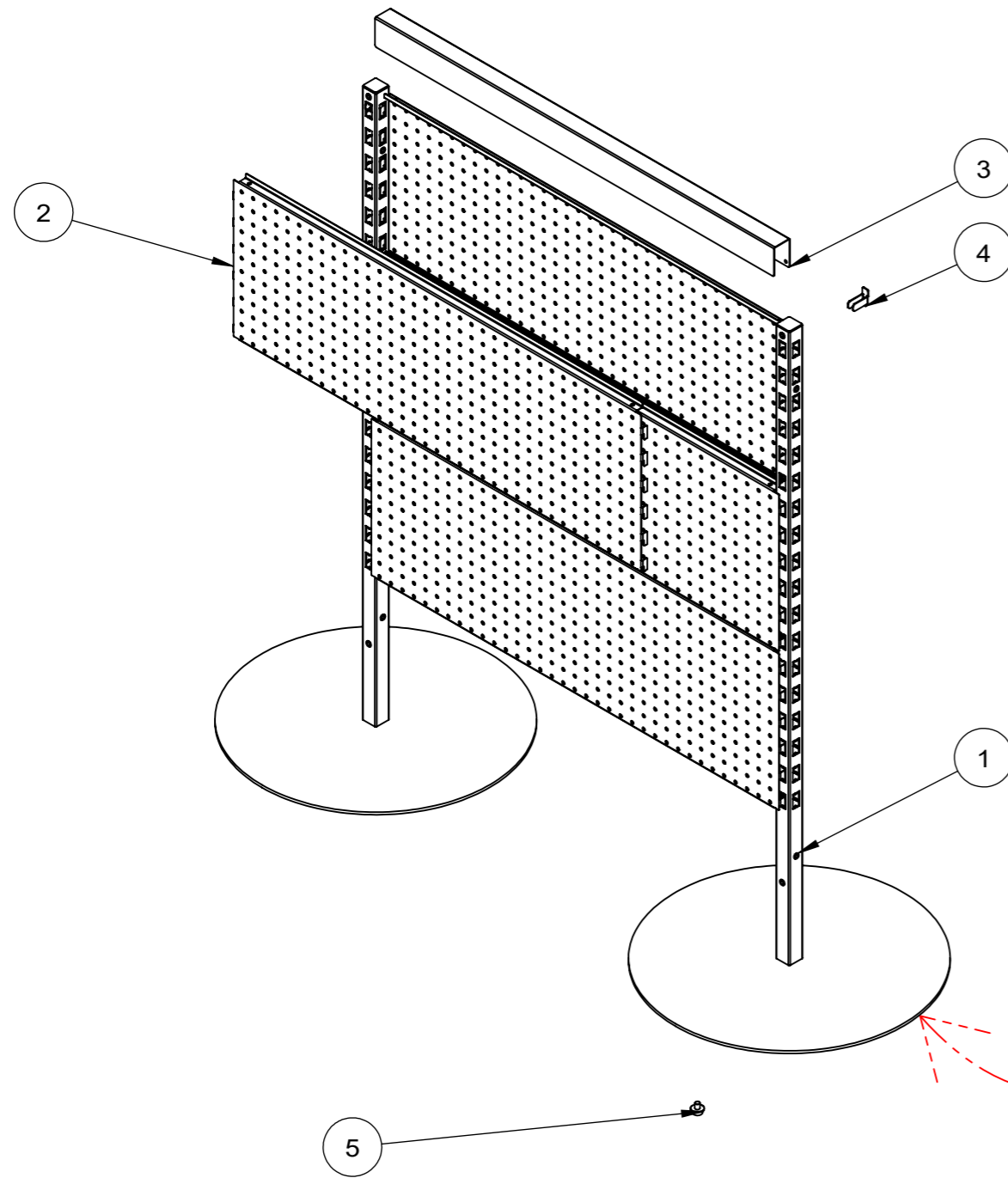

NOTE: SHORT ADJ. FEET: M8, 6mm THD LENGTH
OD25mm BASE, 5mm THK BASE



NOTE: SHORT ADJ. FEET: M8, 6mm THD LENGTH
OD25mm BASE, 5mm THK BASE



T 03 8787 3000 F 03 8787 3025
48-58 Cyber Loop, Dandenong South
VIC 3175 (AUSTRALIA)

© COPYRIGHT. This drawing is the exclusive property of Associated Projects Pty Ltd. It is subject to protection and is strictly confidential. Reproduction in whole or in part is prohibited without obtaining prior permission in writing from the proprietor.

Rev	Date	Description

ALL DIMENSIONS IN (mm)
UNLESS OTHERWISE SPECIFIED
BREAK ALL SHARP EDGES

TOLERANCES
(BEFORE PAINTING
& AFTER PLATING)
X ± 1.00
X.X ± 0.50
X.XX ± 0.10
ANGLES ± 0.5°

A04- EXPLODED VIEW

CLIENT: -

PROJ. NO.: TBA

FINISH: P/C MATTE BLACK

MAT'L: VARIOUS

Page 4

START BAY -QUEUE GONDOLA -W900 H1200 -
PERFORATED

PRODUCT CODE: **RFA2118**

Date: 18/10/2023

Drawn by DH

Checked by NP

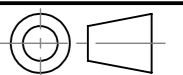

DO NOT SCALE

Scale@A3 1:10