



**This product is an Add Bay**  
 \*Supplied with (1) post only  
 \*Add Bay connects to the post of the neighboring Bay



T 03 8787 3000 F 03 8787 3025  
 48-58 Cyber Loop, Dandenong South  
 VIC 3175 (AUSTRALIA)

© COPYRIGHT. This drawing is the exclusive property of Associated Projects Pty Ltd. It is subject to protection and is strictly confidential. Reproduction in whole or in part is prohibited without obtaining prior permission in writing from the proprietor.

Rev	Date	Description

ALL DIMENSIONS IN (mm)  
 UNLESS OTHERWISE SPECIFIED  
 BREAK ALL SHARP EDGES

TOLERANCES  
 (BEFORE PAINTING  
 & AFTER PLATING)  
 X ± 1.00  
 X.X ± 0.50  
 X.XX ± 0.10  
 ANGLES ± 0.5°

**A01- RENDER**  
**CLIENT: -**  
**PROJ. NO.: TBA**  
**FINISH: P/C PEARL WHITE**  
**MAT'L: VARIOUS**  
**Page 1**

**ADD BAY - QUEUE GONDOLA - WIRE MESH**  
**W900 x H1200**

<b>PRODUCT CODE: RFA2115</b>		
Date:	12/07/2024	
Drawn by	DH	DO NOT SCALE
Checked by	NP	Scale@A3 1:1

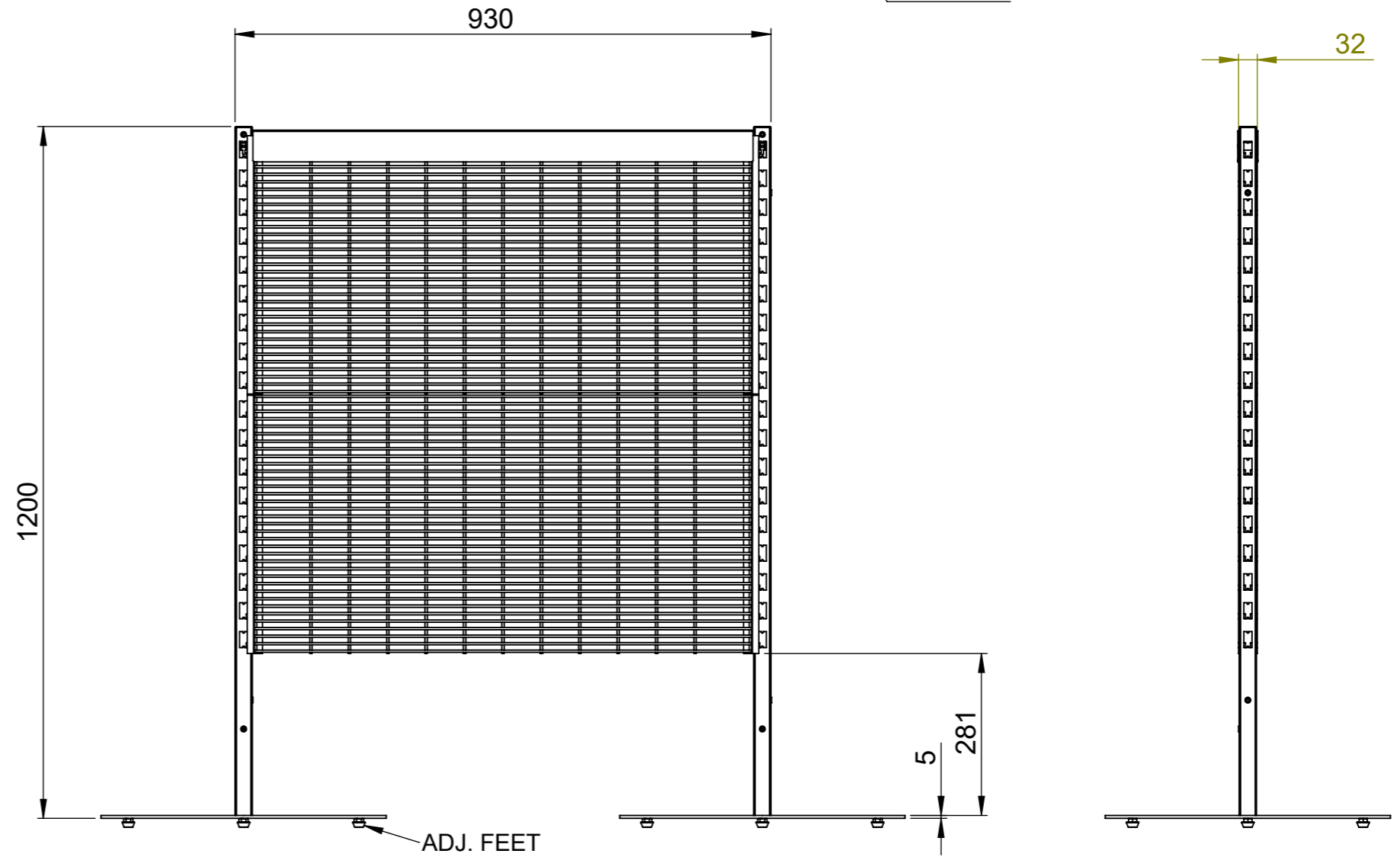
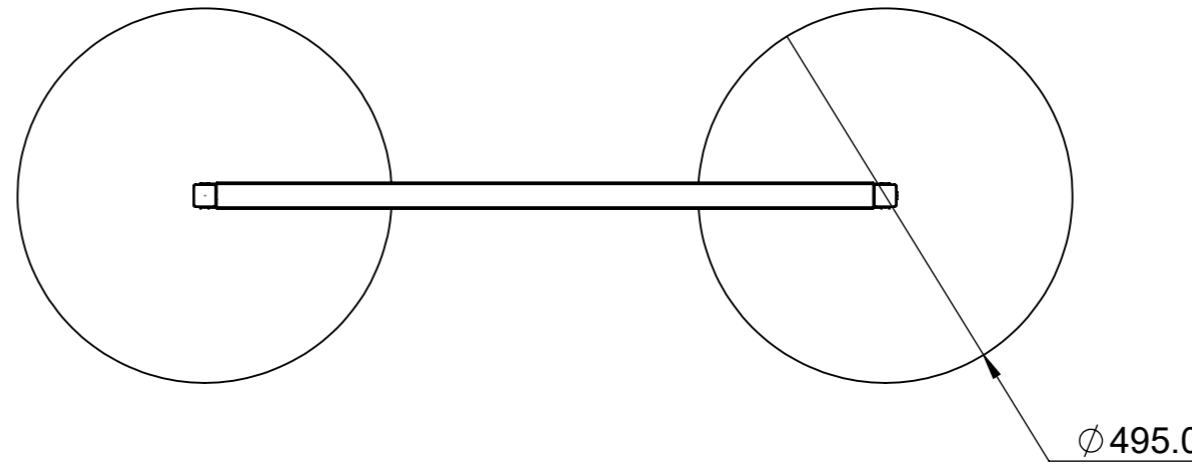
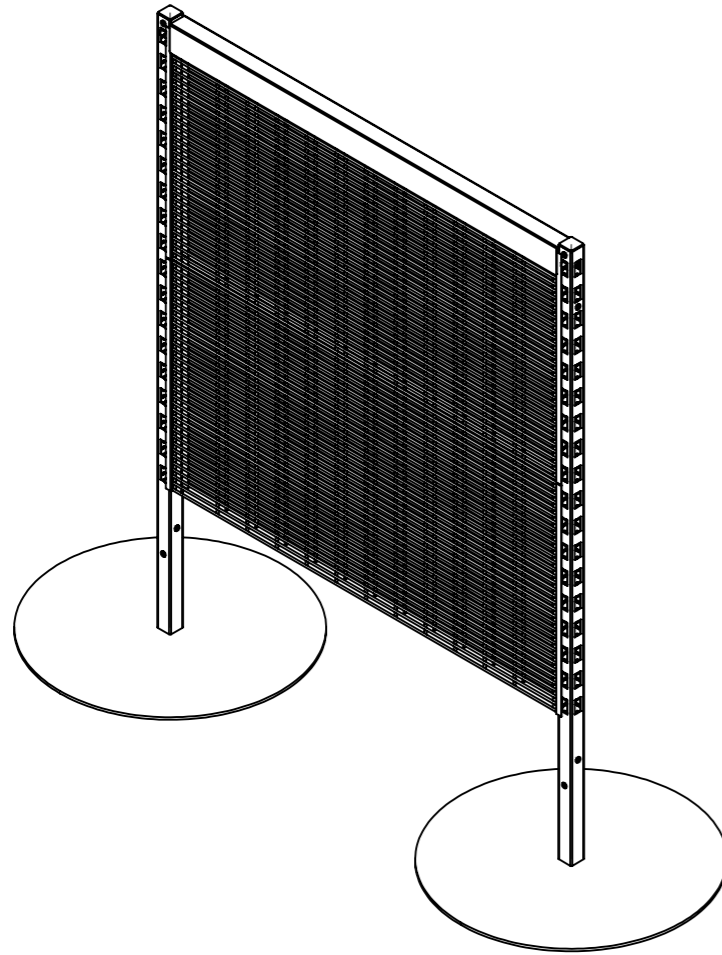

T 03 8787 3000 F 03 8787 3025  
48-58 Cyber Loop, Dandenong South  
VIC 3175 (AUSTRALIA)

© COPYRIGHT. This drawing is the exclusive property of Associated Projects Pty Ltd. It is subject to protection and is strictly confidential. Reproduction in whole or in part is prohibited without obtaining prior permission in writing from the proprietor.

Rev	Date	Description

ALL DIMENSIONS IN (mm)  
UNLESS OTHERWISE SPECIFIED  
BREAK ALL SHARP EDGES

TOLERANCES  
(BEFORE PAINTING  
& AFTER PLATING)  
X ± 1.00  
X.X ± 0.50  
X.XX ± 0.10  
ANGLES ± 0.5°

A02- CLIENT  
CLIENT: -  
PROJ. NO.: TBA  
FINISH: P/C PEARL WHITE  
MAT'L: VARIOUS  
Page 2

ADD BAY - QUEUE GONDOLA - WIRE MESH  
W900 x H1200

PRODUCT CODE: **RFA2115**  
Date: 12/07/2024  
Drawn by DH  
Checked by NP

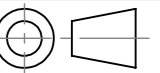
  
DO NOT SCALE  
Scale@A3 1:10

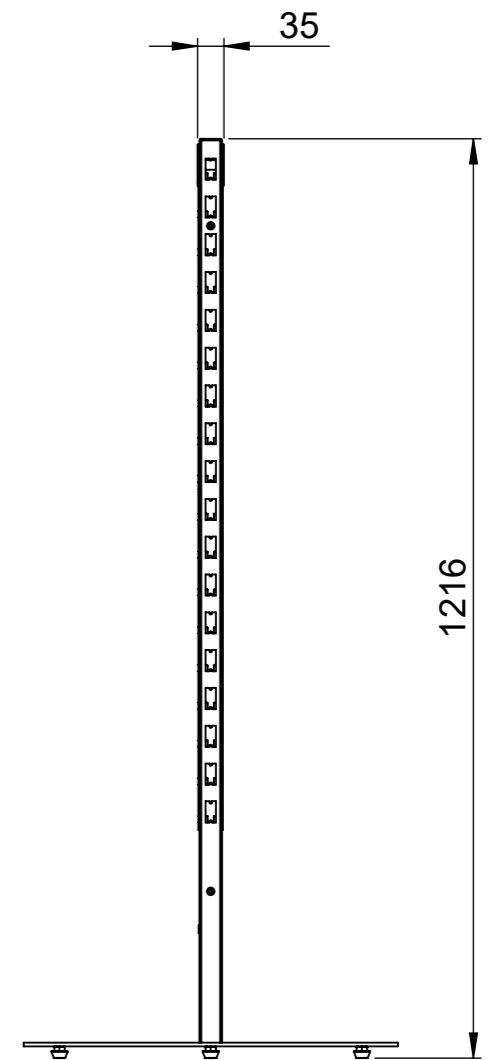
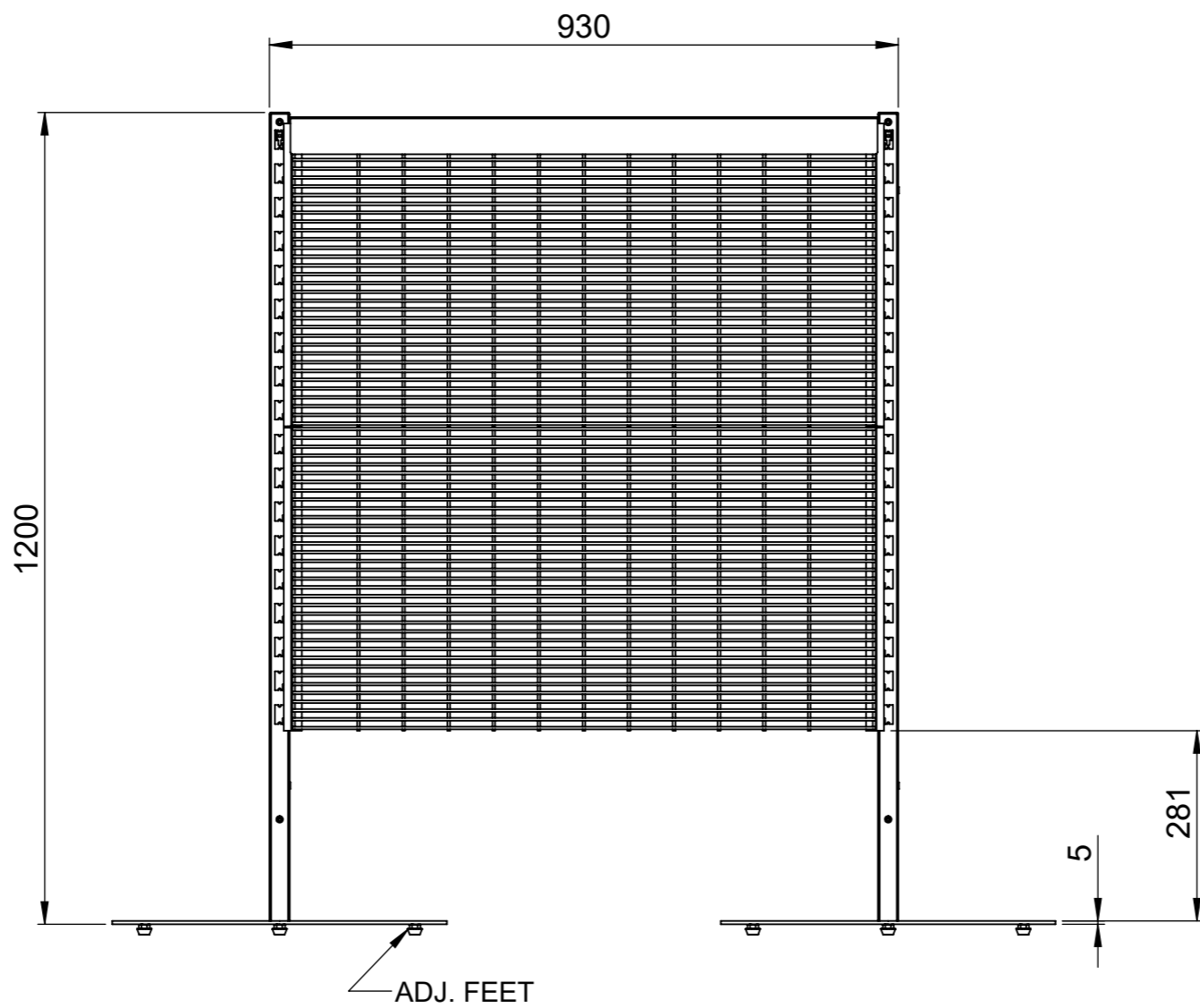
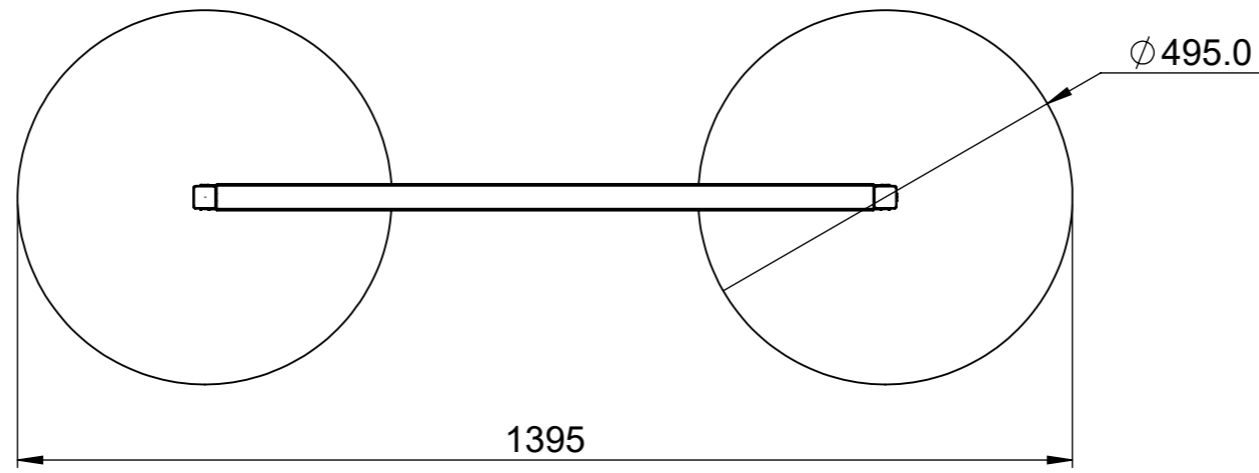

T 03 8787 3000 F 03 8787 3025  
48-58 Cyber Loop, Dandenong South  
VIC 3175 (AUSTRALIA)

© COPYRIGHT. This drawing is the exclusive property of Associated Projects Pty Ltd. It is subject to protection and is strictly confidential. Reproduction in whole or in part is prohibited without obtaining prior permission in writing from the proprietor.

Rev	Date	Description

ALL DIMENSIONS IN (mm)  
UNLESS OTHERWISE SPECIFIED  
BREAK ALL SHARP EDGES

TOLERANCES  
(BEFORE PAINTING  
& AFTER PLATING)  
X ± 1.00  
X.X ± 0.50  
X.XX ± 0.10  
ANGLES ± 0.5°

**A03- COMPONENT**  
CLIENT: -  
PROJ. NO.: TBA  
FINISH: P/C PEARL WHITE  
MAT'L: VARIOUS  
Page 3

ADD BAY - QUEUE GONDOLA - WIRE MESH W900 x H1200		
PRODUCT CODE: <b>RFA2115</b>	Date: 12/07/2024	
Drawn by: DH	Checked by: NP	DO NOT SCALE
Scale@A3 1:10		

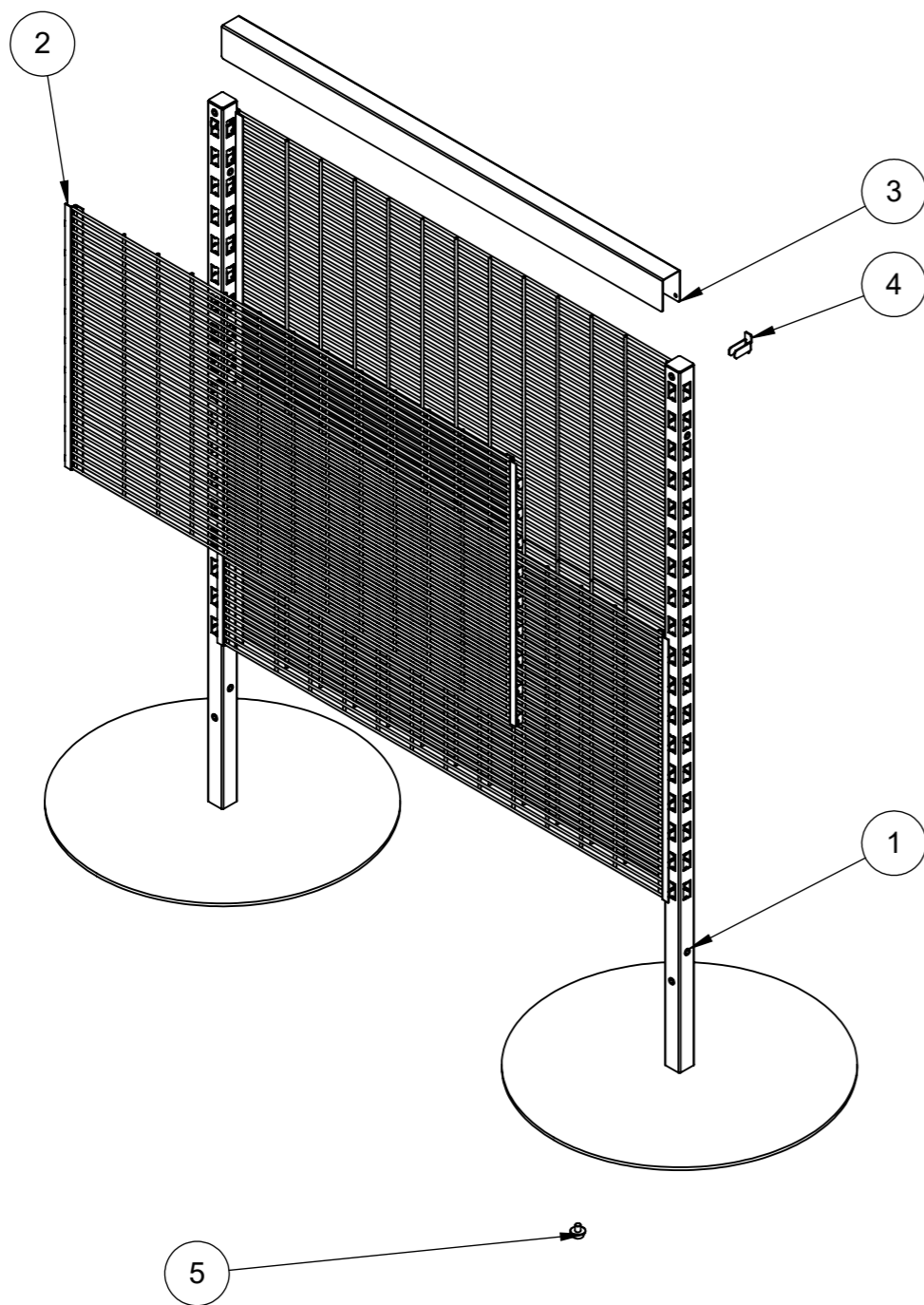

ITEM NO.	PRODUCT CODE	DESCRIPTION	FINISH	QTY.
1	RFA2700	RFA2700 QG POST	P/C PEARL WHITE	2
2	RFA2756	WIRE MESH PANEL - CLIP IN PANEL - W900XH300	P/C PEARL WHITE	4
3	RFA2721	QUEUE GONDOLA - TOP CAP	P/C PEARL WHITE	1
4	RFA2725	QUEUE GONDOLA - LOCKING CLIP	P/C PEARL WHITE	2
5	-	ADJ. FEET, M8 x6mm THD, BASE OD25mm, 5mm THK	RAW	8



T 03 8787 3000 F 03 8787 3025  
48-58 Cyber Loop, Dandenong South  
VIC 3175 (AUSTRALIA)

© COPYRIGHT. This drawing is the exclusive property of Associated Projects Pty Ltd. It is subject to protection and is strictly confidential. Reproduction in whole or in part is prohibited without obtaining prior permission in writing from the proprietor.

Rev	Date	Description

ALL DIMENSIONS IN (mm)  
UNLESS OTHERWISE SPECIFIED  
BREAK ALL SHARP EDGES

TOLERANCES  
(BEFORE PAINTING  
& AFTER PLATING)  
X ± 1.00  
X.X ± 0.50  
X.XX ± 0.10  
ANGLES ± 0.5°

A04- EXPLODED VIEW

CLIENT: -

PROJ. NO.: TBA

FINISH: P/C PEARL WHITE

MAT'L: VARIOUS

Page 4

ADD BAY - QUEUE GONDOLA - WIRE MESH  
W900 x H1200

PRODUCT CODE: **RFA2115**

Date: 12/07/2024

Drawn by DH

Checked by NP

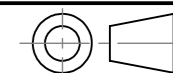

DO NOT SCALE

Scale@A3 1:10