



This product is an Add Bay  
 \* Supplied with (1) post Only  
 \* Connects to the post of the neighboring Bay



T 03 8787 3000 F 03 8787 3025  
 48-58 Cyber Loop, Dandenong South  
 VIC 3175 (AUSTRALIA)

© COPYRIGHT. This drawing is the exclusive property of Associated Projects Pty Ltd. It is subject to protection and is strictly confidential. Reproduction in whole or in part is prohibited without obtaining prior permission in writing from the proprietor.

Rev	Date	Description

ALL DIMENSIONS IN (mm)  
 UNLESS OTHERWISE SPECIFIED  
 BREAK ALL SHARP EDGES

TOLERANCES  
 (BEFORE PAINTING  
 & AFTER PLATING)  
 X ± 1.00  
 X.X ± 0.50  
 X.XX ± 0.10  
 ANGLES ± 0.5°

A01- RENDER  
 CLIENT: -  
 PROJ. NO.: TBA  
 FINISH: P/C PEARL WHITE  
 MAT'L: VARIOUS  
 Page 1

ADD BAY -QUEUE GONDOLA -W900 H1200 -NON -  
 PREFORATED

PRODUCT CODE: **RFA2107**

Date: 18/10/2023

Drawn by DH

Checked by NP

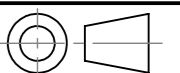

DO NOT SCALE

Scale@A3 1:1

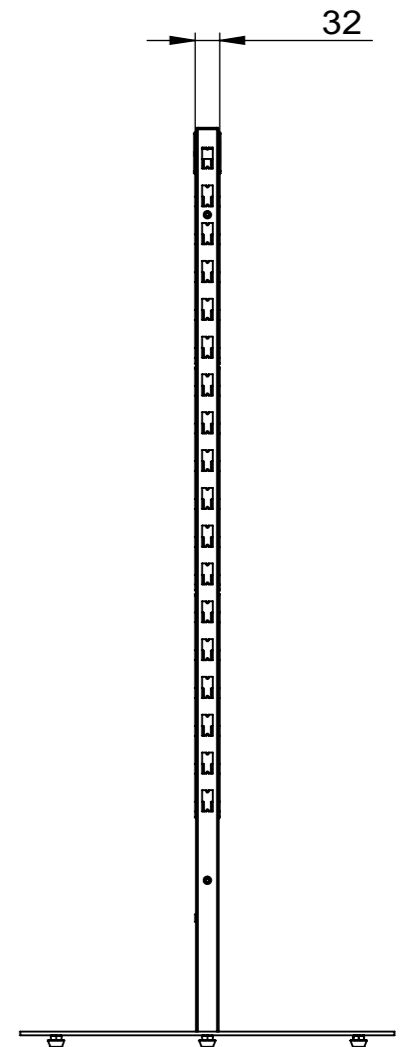
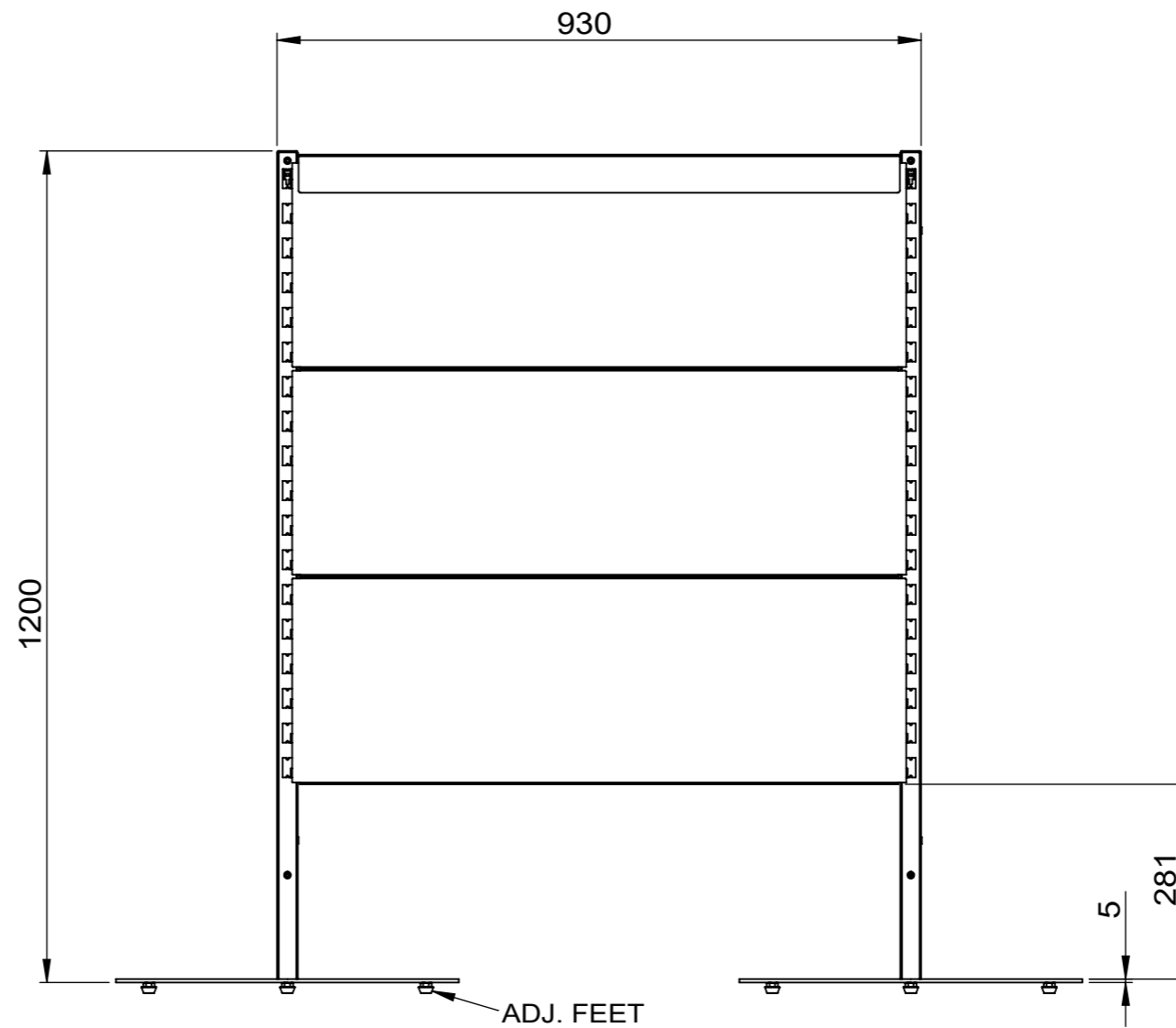
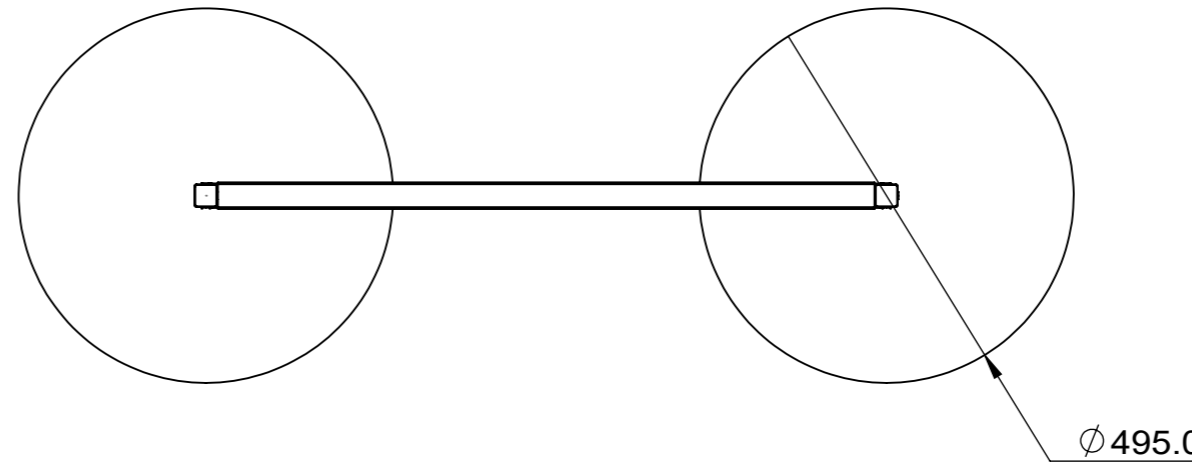
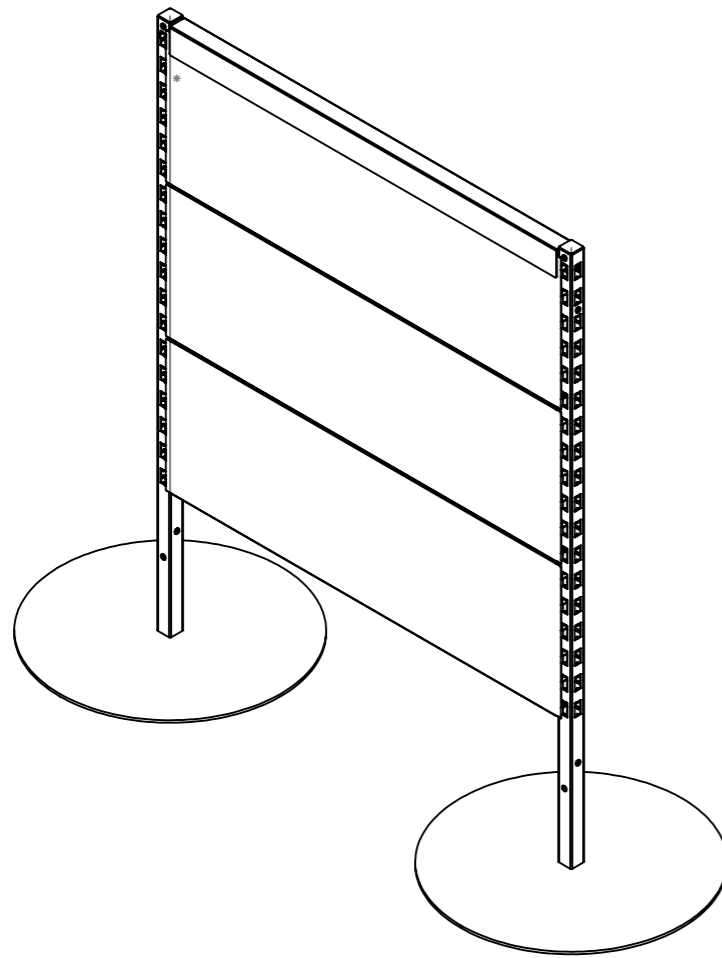

T 03 8787 3000 F 03 8787 3025  
 48-58 Cyber Loop, Dandenong South  
 VIC 3175 (AUSTRALIA)

© COPYRIGHT. This drawing is the exclusive property of Associated Projects Pty Ltd. It is subject to protection and is strictly confidential. Reproduction in whole or in part is prohibited without obtaining prior permission in writing from the proprietor.

Rev	Date	Description

ALL DIMENSIONS IN (mm)  
 UNLESS OTHERWISE SPECIFIED  
 BREAK ALL SHARP EDGES

TOLERANCES  
 (BEFORE PAINTING  
 & AFTER PLATING)  
 X ± 1.00  
 X.X ± 0.50  
 X.XX ± 0.10  
 ANGLES ± 0.5°

A02- CLIENT

CLIENT: -  
 PROJ. NO.: TBA  
 FINISH: P/C PEARL WHITE  
 MAT'L: VARIOUS  
 Page 2

ADD BAY -QUEUE GONDOLA -W900 H1200 -NON -  
 PREFORATED

PRODUCT CODE: **RFA2107**

Date: 18/10/2023

Drawn by DH

Checked by NP

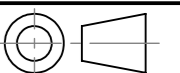

DO NOT SCALE

Scale@A3 1:10

ITEM NO.	PRODUCT CODE	DESCRIPTION	FINISH	QTY.
1	RFA2700	POST - QUEUE GONDOLA	P/C PEARL WHITE	2
2	RFA2752	CLIP IN PANEL - W900XH300 - NON PERFORATED	P/C PEARL WHITE	6
3	RFA2721	QUEUE GONDOLA - TOP CAP	P/C PEARL WHITE	1
4	-	LOCKING CLLP	SAME AS THE POST	2
5	-	ADJ. FEET, M8 x6mm THD, BASE OD25mm, 5mm THK	RAW	8

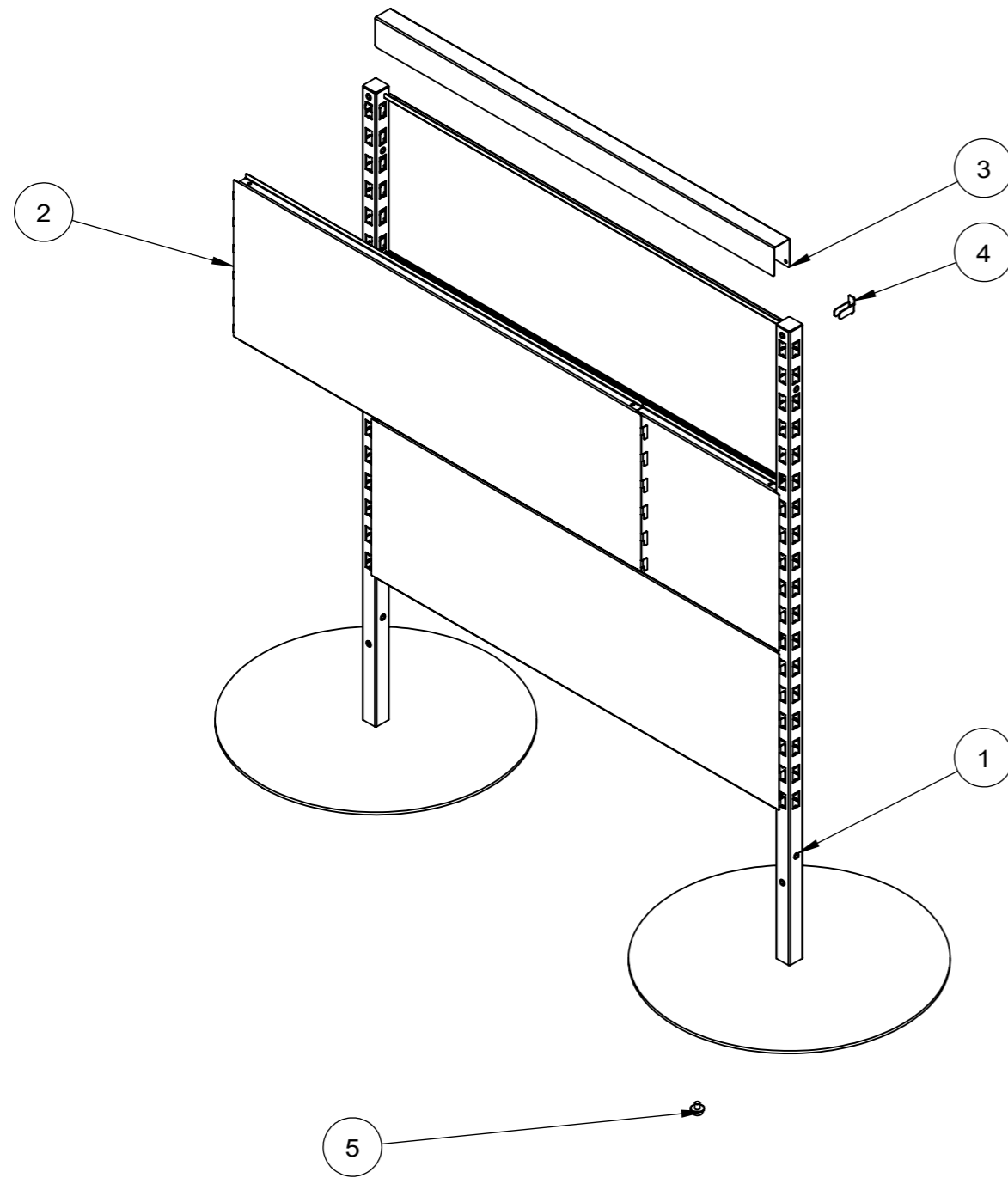

T 03 8787 3000 F 03 8787 3025  
48-58 Cyber Loop, Dandenong South  
VIC 3175 (AUSTRALIA)

© COPYRIGHT. This drawing is the exclusive property of Associated Projects Pty Ltd. It is subject to protection and is strictly confidential. Reproduction in whole or in part is prohibited without obtaining prior permission in writing from the proprietor.

Rev	Date	Description

ALL DIMENSIONS IN (mm)  
UNLESS OTHERWISE SPECIFIED  
BREAK ALL SHARP EDGES

TOLERANCES  
(BEFORE PAINTING  
& AFTER PLATING)  
X ± 1.00  
X.X ± 0.50  
X.XX ± 0.10  
ANGLES ± 0.5°

A04- EXPLODED VIEW

CLIENT: -

PROJ. NO.: TBA

FINISH: P/C PEARL WHITE

MAT'L: VARIOUS

Page 4

ADD BAY -QUEUE GONDOLA -W900 H1200 -NON - PREFORATED

PRODUCT CODE: **RFA2107**

Date: 18/10/2023

Drawn by DH

Checked by NP

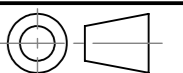

DO NOT SCALE

Scale@A3 1:10