

T 03 8787 3000 F 03 8787 3025  
 48-58 Cyber Loop, Dandenong South  
 VIC 3175 (AUSTRALIA)

© COPYRIGHT. This drawing is the exclusive property of Associated Projects Pty Ltd. It is subject to protection and is strictly confidential. Reproduction in whole or in part is prohibited without obtaining prior permission in writing from the proprietor.

| Rev | Date | Description |
|-----|------|-------------|
|     |      |             |
|     |      |             |
|     |      |             |
|     |      |             |

ALL DIMENSIONS IN (mm)  
 UNLESS OTHERWISE SPECIFIED  
 BREAK ALL SHARP EDGES

TOLERANCES  
 (BEFORE PAINTING  
 & AFTER PLATING)  
 X ± 1.00  
 X.X ± 0.50  
 X.XX ± 0.10  
 ANGLES ± 0.5°

A01- RENDER  
 CLIENT: -  
 PROJ. NO.: TBA  
 FINISH: P/C MATTE BLACK  
 MAT'L: VARIOUS  
 Page 1

GONDOLA END - SOFT SHELL - W900XH1815XD450 -  
 PERFORATED - W/ INTERLOCKER

PRODUCT CODE: **RFA2091**

Date: 2/11/2023

Drawn by DH

Checked by NP

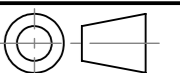

DO NOT SCALE

Scale@A3 1:20

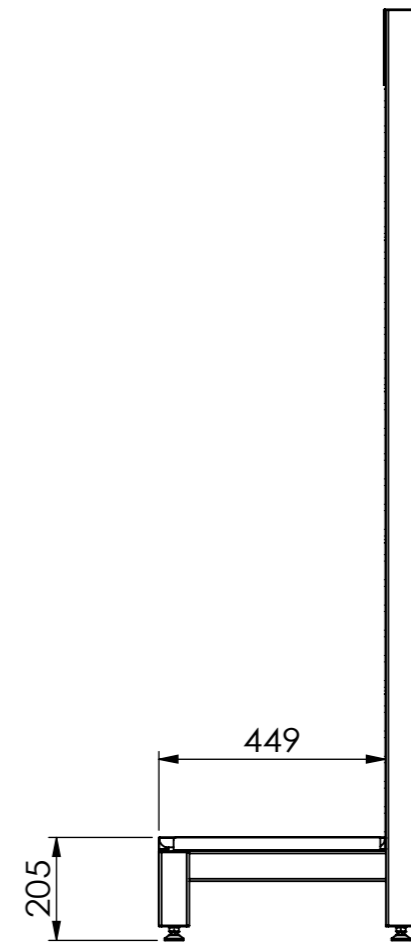
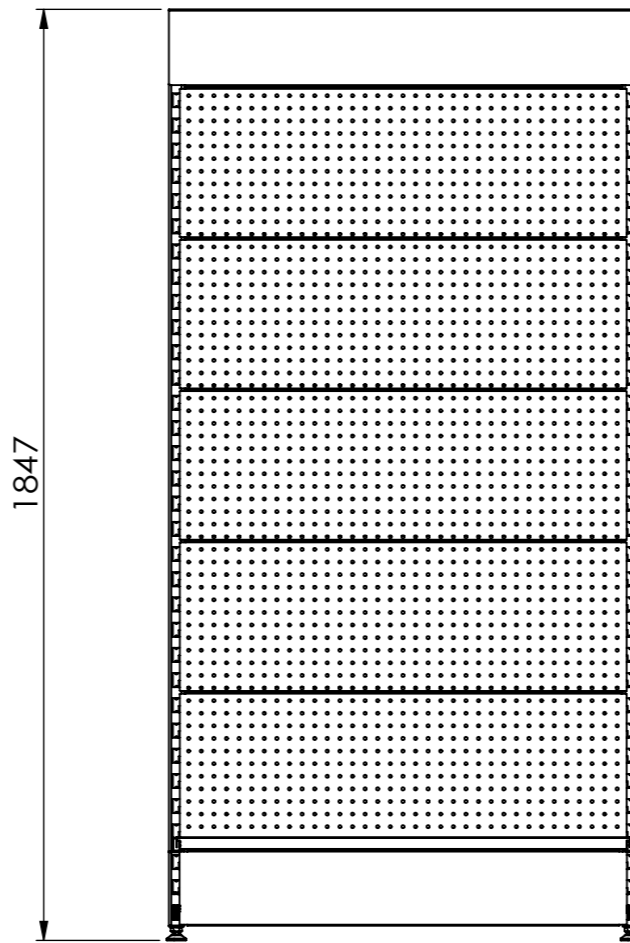
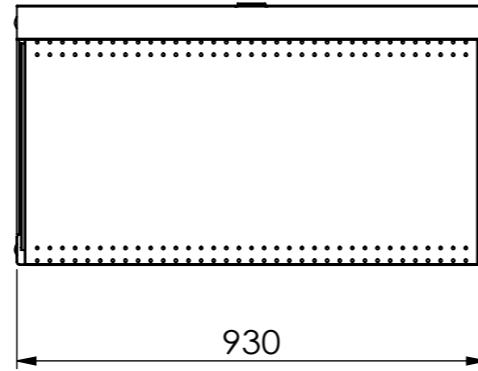
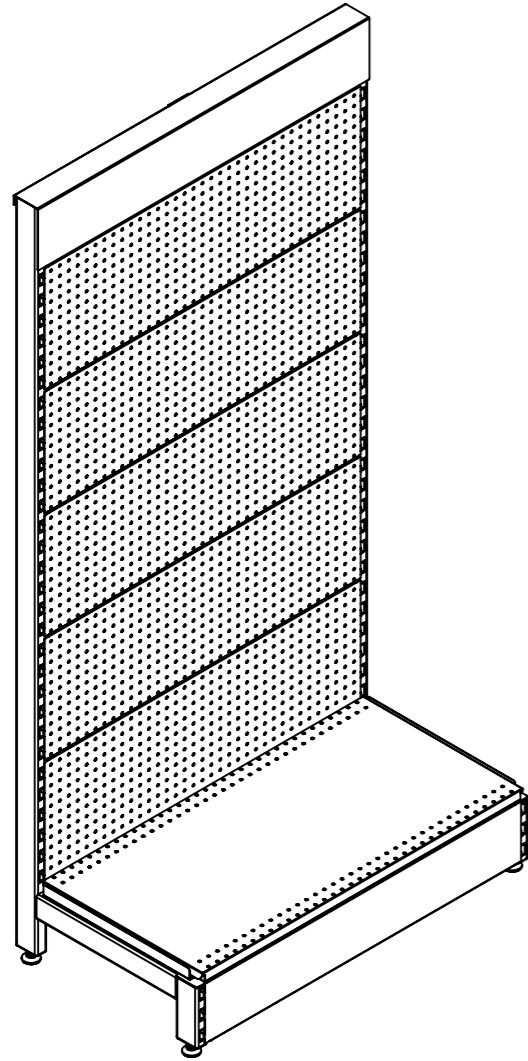

T 03 8787 3000 F 03 8787 3025  
48-58 Cyber Loop, Dandenong South  
VIC 3175 (AUSTRALIA)

© COPYRIGHT. This drawing is the exclusive property of Associated Projects Pty Ltd. It is subject to protection and is strictly confidential. Reproduction in whole or in part is prohibited without obtaining prior permission in writing from the proprietor.

| Rev | Date | Description |
|-----|------|-------------|
|     |      |             |
|     |      |             |
|     |      |             |
|     |      |             |

ALL DIMENSIONS IN (mm)  
UNLESS OTHERWISE SPECIFIED  
BREAK ALL SHARP EDGES

TOLERANCES  
(BEFORE PAINTING  
& AFTER PLATING)  
X ± 1.00  
X.X ± 0.50  
X.XX ± 0.10  
ANGLES ± 0.5°

A02- CLIENT

CLIENT: -

PROJ. NO.: TBA

FINISH: P/C MATTE BLACK

MAT'L: VARIOUS

Page 2

GONDOLA END - SOFT SHELL - W900XH1815XD450 -  
PERFORATED - W/ INTERLOCKER

PRODUCT CODE: **RFA2091**

Date: 2/11/2023

Drawn by DH

Checked by NP

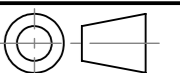

DO NOT SCALE

Scale@A3 1:15

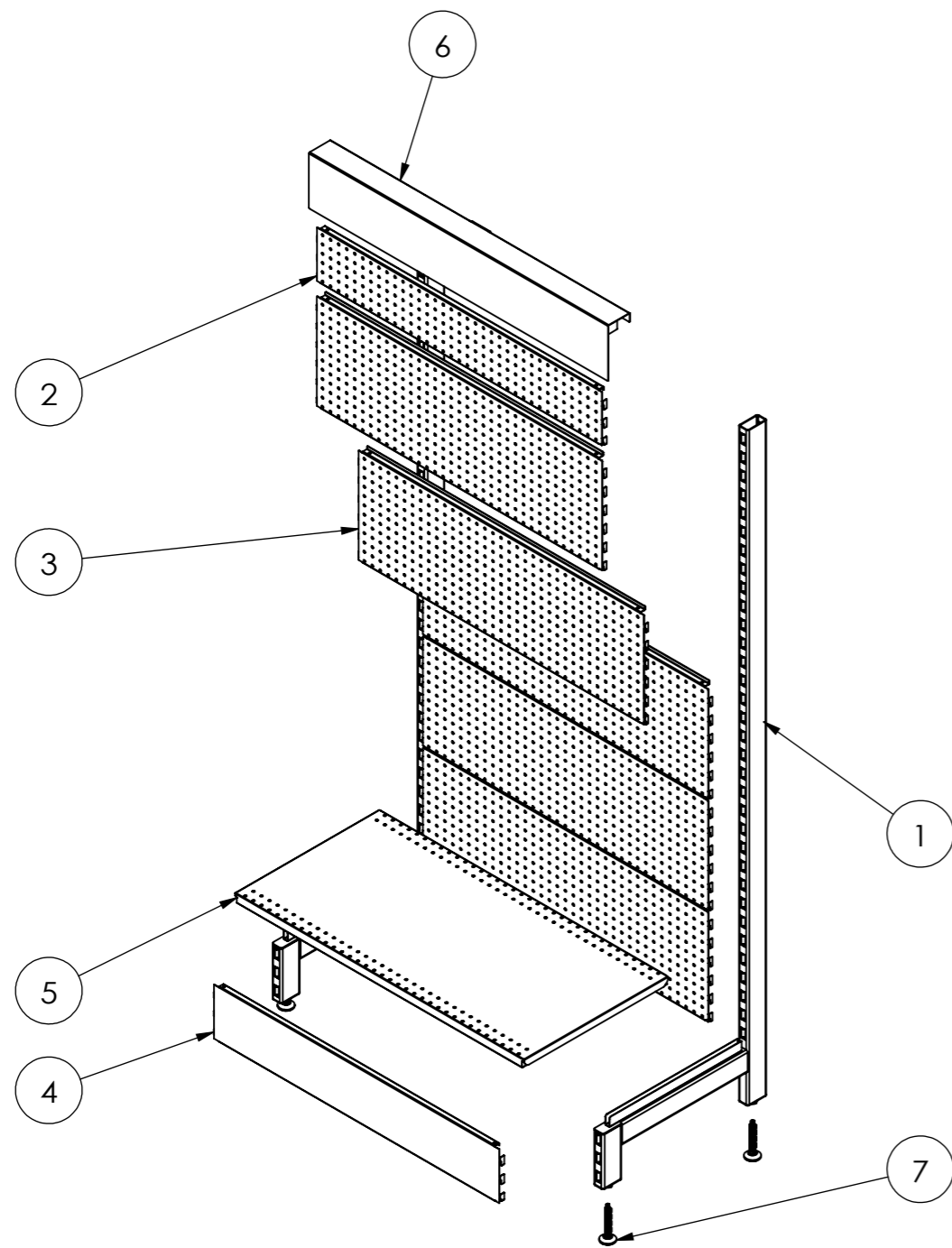

| ITEM NO. | PRODUCT CODE | DESCRIPTION  | FINISH          | QTY. |
|----------|--------------|--|-----------------|------|
| 1        | RFA2344      | POST - GONDOLA END - H1815XD900 - W/D 450 LEGS                     | P/C MATTE BLACK | 2    |
| 2        | RFA2304      | CLIP IN PANEL - W900XH150 - PERFORATED                             | P/C MATTE BLACK | 1    |
| 3        | RFA2307      | CLIP IN PANEL - W900XH300 - PERFORATED                             | P/C MATTE BLACK | 5    |
| 4        | RFA2322      | 900W X 150H SKIRT  | P/C MATTE BLACK | 1    |
| 5        | RFA0411      | SHELF - W900XD450 - W/. DOUBLE STIFFENER                           | P/C MATTE BLACK | 1    |
| 6        | RFA2345      | TOP CAP - W900 - SLIMLINE INTERLOCKER - FOR SOFT SHELL GONDOLA END | P/C MATTE BLACK | 1    |
| 7        | -            | ADJ. FEET OD38_M12_H70THD  | RAW             | 4    |



T 03 8787 3000 F 03 8787 3025  
48-58 Cyber Loop, Dandenong South  
VIC 3175 (AUSTRALIA)

© COPYRIGHT. This drawing is the exclusive property of Associated Projects Pty Ltd. It is subject to protection and is strictly confidential. Reproduction in whole or in part is prohibited without obtaining prior permission in writing from the proprietor.

| Rev | Date | Description |
|-----|------|-------------|
|     |      |             |
|     |      |             |
|     |      |             |
|     |      |             |

ALL DIMENSIONS IN (mm)  
UNLESS OTHERWISE SPECIFIED  
BREAK ALL SHARP EDGES

TOLERANCES  
(BEFORE PAINTING  
& AFTER PLATING)  
X ± 1.00  
X.X ± 0.50  
X.XX ± 0.10  
ANGLES ± 0.5°

A03- EXPLODED VIEW

CLIENT: -

PROJ. NO.: TBA

FINISH: P/C MATTE BLACK

MAT'L: VARIOUS

Page 3

GONDOLA END - SOFT SHELL - W900XH1815XD450 - PERFORATED - W/. INTERLOCKER

PRODUCT CODE: **RFA2091**

Date: 2/11/2023

Drawn by DH

Checked by NP

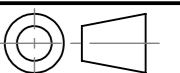

DO NOT SCALE

Scale@A3 1:15