



T 03 8787 3000 F 03 8787 3025  
 48-58 Cyber Loop, Dandenong South  
 VIC 3175 (AUSTRALIA)

© COPYRIGHT. This drawing is the exclusive property of Associated Projects Pty Ltd. It is subject to protection and is strictly confidential. Reproduction in whole or in part is prohibited without obtaining prior permission in writing from the proprietor.

Rev	Date	Description

ALL DIMENSIONS IN (mm)  
 UNLESS OTHERWISE SPECIFIED  
 BREAK ALL SHARP EDGES

TOLERANCES  
 (BEFORE PAINTING  
 & AFTER PLATING)  
 X ± 1.00  
 X.X ± 0.50  
 X.XX ± 0.10  
 ANGLES ± 0.5°

**A01- RENDER**  
**CLIENT: -**  
**PROJ. NO.: TBA**  
**FINISH: P/C MATTE BLACK**  
**MAT'L: Material <not specified>**  
**Page 1**

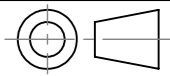
<b>START BAY - DOUBLE SIDED GONDOLA - SOFT SHELL - W1200XH1515XD450 - WIRE ESH PANELS</b>	
<b>PRODUCT CODE: RFA2080</b>	
Date: 11/10/2023	DO NOT SCALE
Drawn by DH	Checked by NP
Scale@A3 1:20	

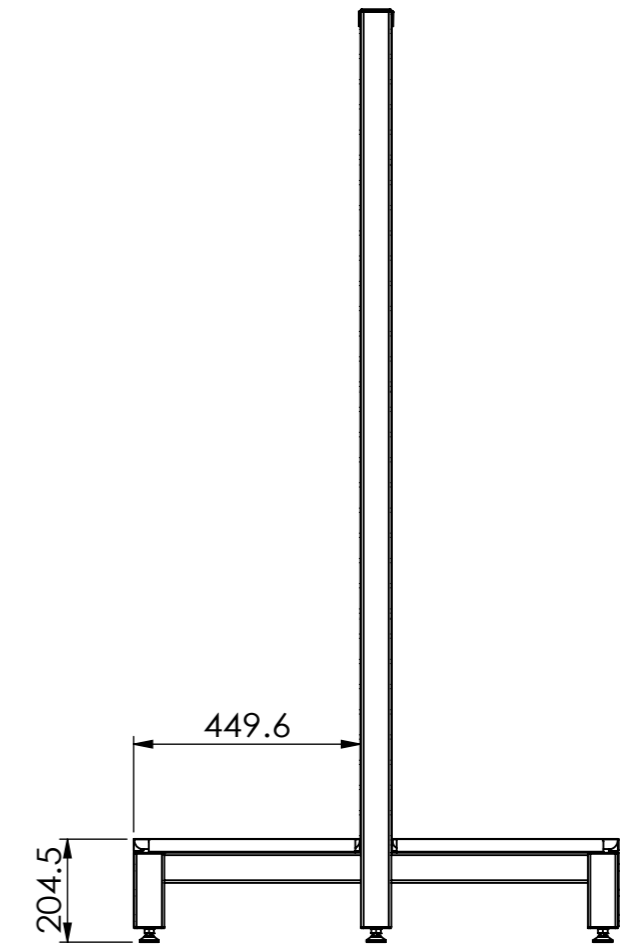
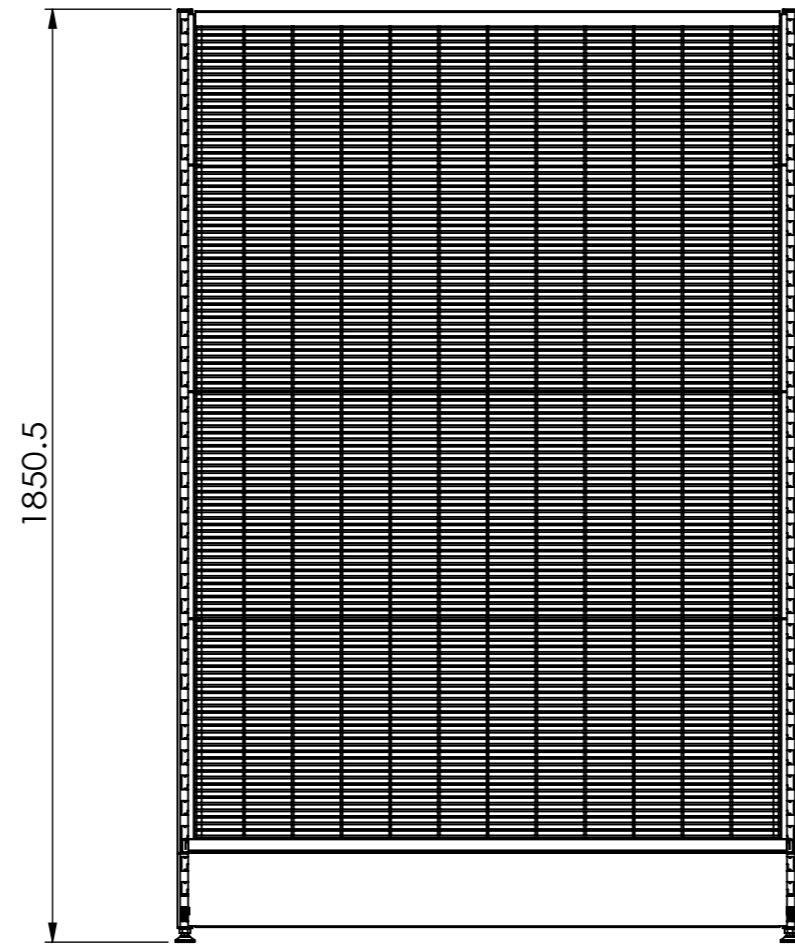
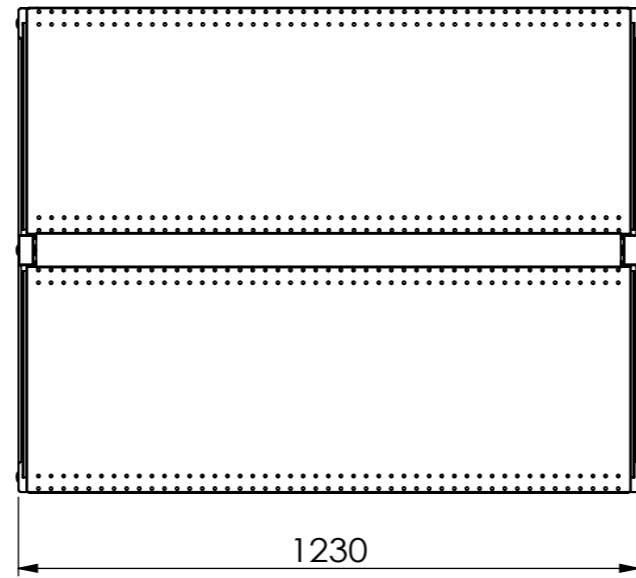
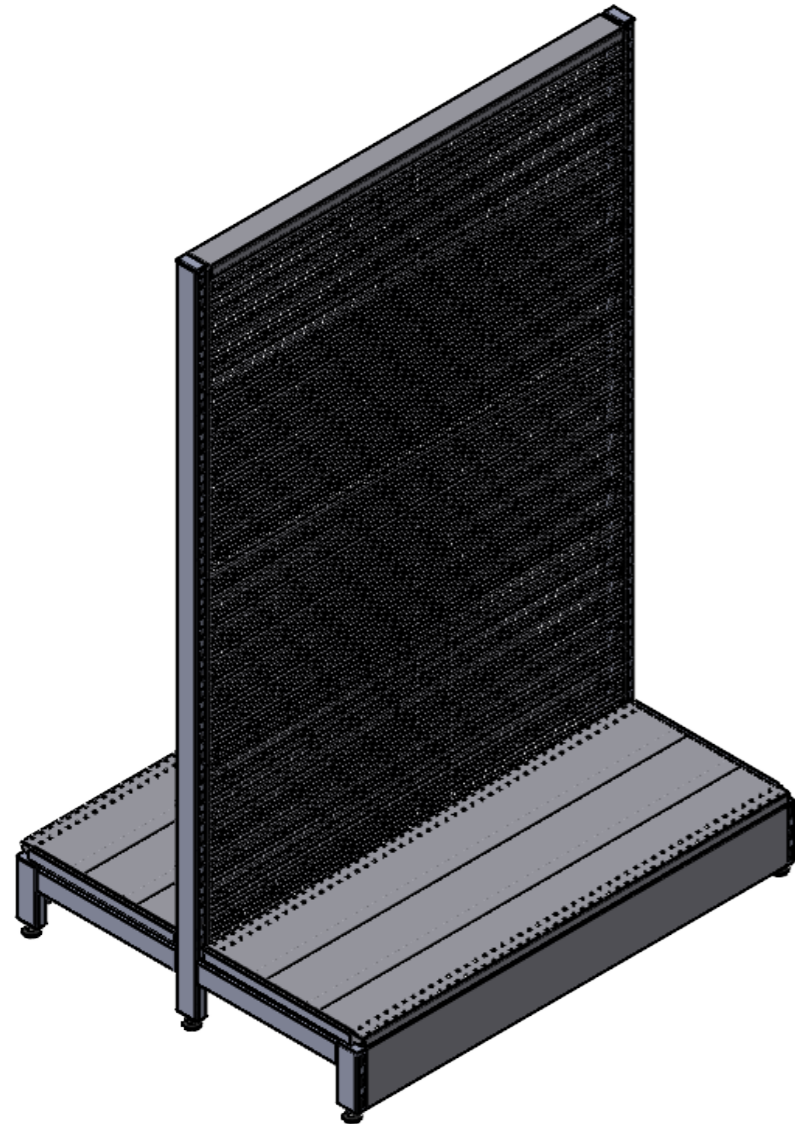

T 03 8787 3000 F 03 8787 3025  
 48-58 Cyber Loop, Dandenong South  
 VIC 3175 (AUSTRALIA)

© COPYRIGHT. This drawing is the exclusive property of Associated Projects Pty Ltd. It is subject to protection and is strictly confidential. Reproduction in whole or in part is prohibited without obtaining prior permission in writing from the proprietor.

Rev	Date	Description

ALL DIMENSIONS IN (mm)  
 UNLESS OTHERWISE SPECIFIED  
 BREAK ALL SHARP EDGES

TOLERANCES  
 (BEFORE PAINTING  
 & AFTER PLATING)  
 X ± 1.00  
 X.X ± 0.50  
 X.XX ± 0.10  
 ANGLES ± 0.5°

A02- CLIENT  
 CLIENT: -  
 PROJ. NO.: TBA  
 FINISH: P/C MATTE BLACK  
 MAT'L: Material <not specified>  
 Page 2

START BAY - DOUBLE SIDED GONDOLA - SOFT SHELL - W1200XH1515XD450 - WIRE ESH PANELS		
PRODUCT CODE: <b>RFA2080</b>	Date: 11/10/2023	
Drawn by: DH	Checked by: NP	Scale@A3 1:15

ITEM NO.	PRODUCT CODE	DESCRIPTION	FINISH	QTY.
1	RFA2332	POST - GONDOLA - DOUBLE SIDED - H1815XD900 - W/.D 450 LEGS	P/C MATTE BLACK	2
2	RFA2354	WIRE MESH PANEL - CLIP IN PANEL - W1200XH300	P/C MATTE BLACK	2
3	RFA2360	WIRE MESH PANEL - CLIP IN PANEL - W1200XH450	P/C MATTE BLACK	6
4	RFA0414	SHELF - W1200XD450 - W/. DOUBLE STIFFENER	P/C MATTE BLACK	2
5	RFA2335	TOP CAP - W1200XH30 - W/. H30 RETURN FOLDS	P/C MATTE BLACK	1
6	RFA2323	1200W X 150H SKIRT	P/C MATTE BLACK	2
7	-	PLASTIC ENDCAP	BLACK	2
8	-	ADJ. FEET OD38_M12_H70THD	RAW	6

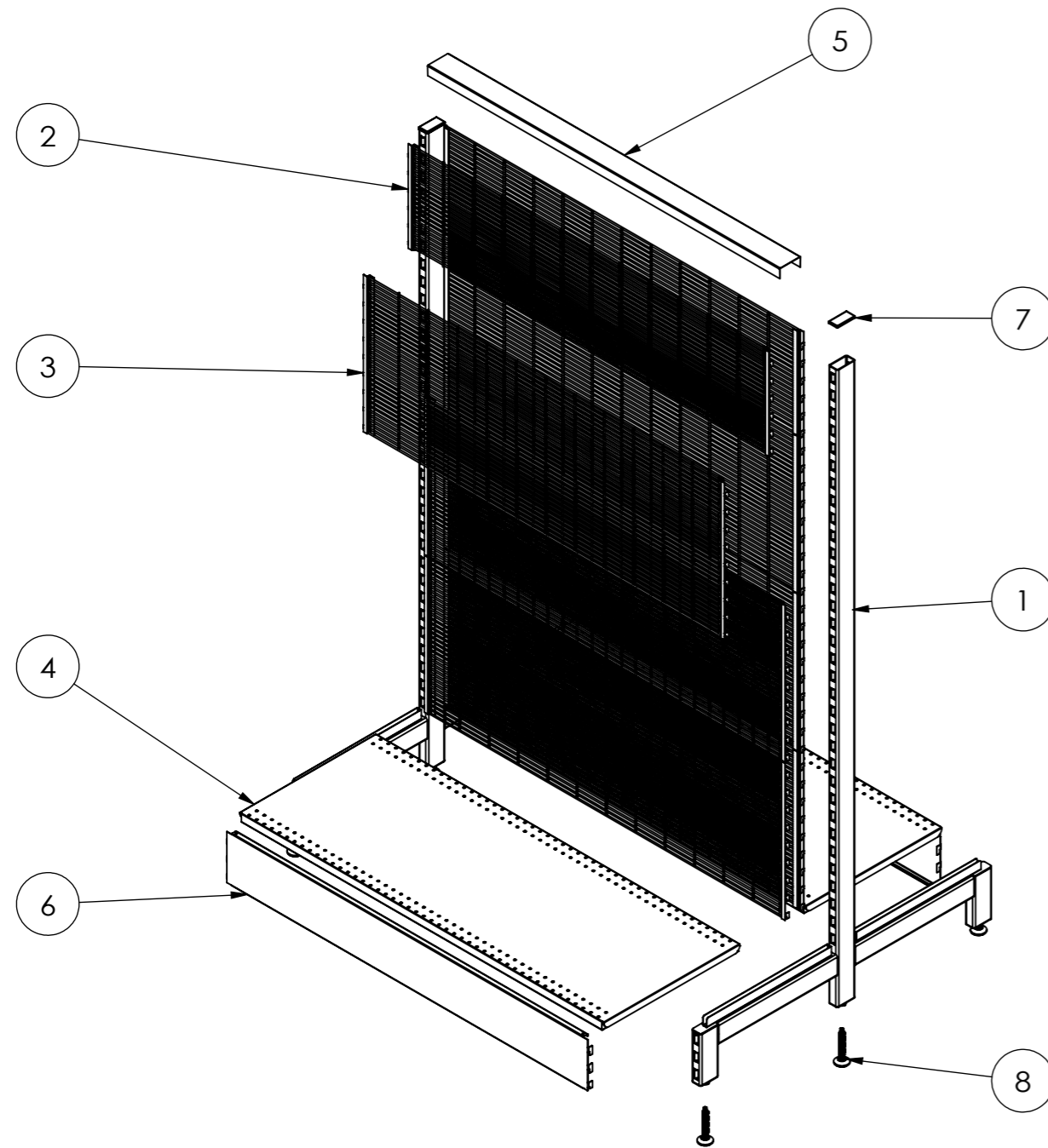

T 03 8787 3000 F 03 8787 3025  
48-58 Cyber Loop, Dandenong South  
VIC 3175 (AUSTRALIA)

© COPYRIGHT. This drawing is the exclusive property of Associated Projects Pty Ltd. It is subject to protection and is strictly confidential. Reproduction in whole or in part is prohibited without obtaining prior permission in writing from the proprietor.

Rev	Date	Description

ALL DIMENSIONS IN (mm)  
UNLESS OTHERWISE SPECIFIED  
BREAK ALL SHARP EDGES

TOLERANCES  
(BEFORE PAINTING  
& AFTER PLATING)  
X ± 1.00  
X.X ± 0.50  
X.XX ± 0.10  
ANGLES ± 0.5°

**A03- EXPLODED VIEW**  
CLIENT: -  
PROJ. NO.: TBA  
FINISH: P/C MATTE BLACK  
MAT'L: Material <not specified>  
Page 3

**START BAY - DOUBLE SIDED GONDOLA - SOFT SHELL - W1200XH1515XD450 - WIRE ESH PANELS**

PRODUCT CODE: **RFA2080**

Date: 11/10/2023

Drawn by: DH

Checked by: NP

DO NOT SCALE

Scale@A3 1:15