



T 03 8787 3000 F 03 8787 3025  
 48-58 Cyber Loop, Dandenong South  
 VIC 3175 (AUSTRALIA)

© COPYRIGHT. This drawing is the exclusive property of Associated Projects Pty Ltd. It is subject to protection and is strictly confidential. Reproduction in whole or in part is prohibited without obtaining prior permission in writing from the proprietor.

Rev	Date	Description

ALL DIMENSIONS IN (mm)  
 UNLESS OTHERWISE SPECIFIED  
 BREAK ALL SHARP EDGES

TOLERANCES  
 (BEFORE PAINTING  
 & AFTER PLATING)  
 X ± 1.00  
 X.X ± 0.50  
 X.XX ± 0.10  
 ANGLES ± 0.5°

**A01- RENDER**  
**CLIENT: -**  
**PROJ. NO.: TBA**  
**FINISH: P/C MATTE BLACK**  
**MAT'L: Material <not specified>**  
**Page 1**

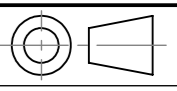
<b>START BAY - DOUBLE SIDED GONDOLA-WIRE MESH</b> W900 x H1515 x D450		
<b>PRODUCT CODE: RFA2050</b>		
Date:	12/07/2024	
Drawn by	DH	DO NOT SCALE
Checked by	NP	Scale@A3 1:20

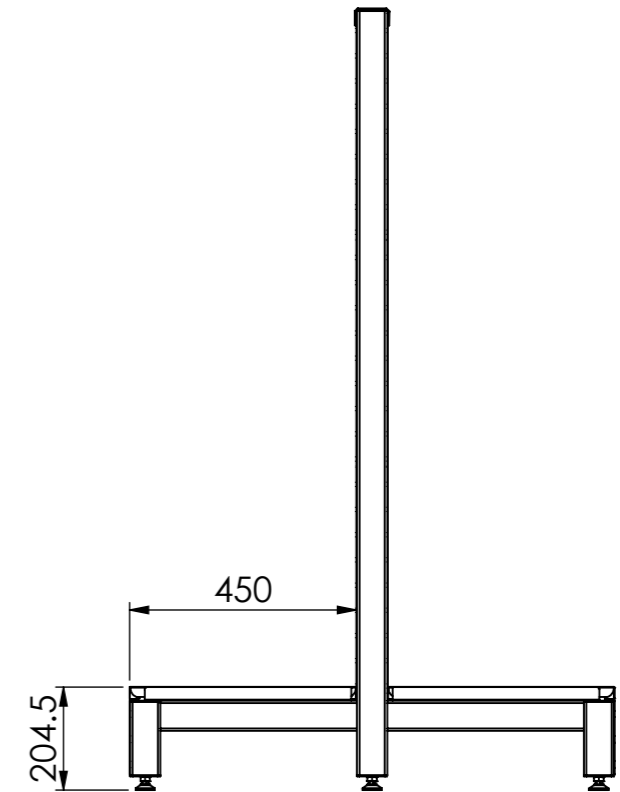
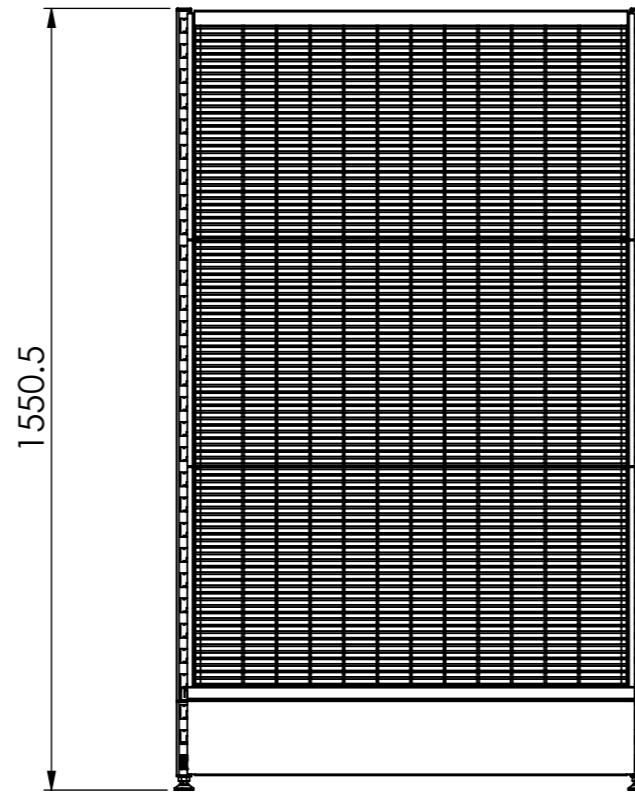
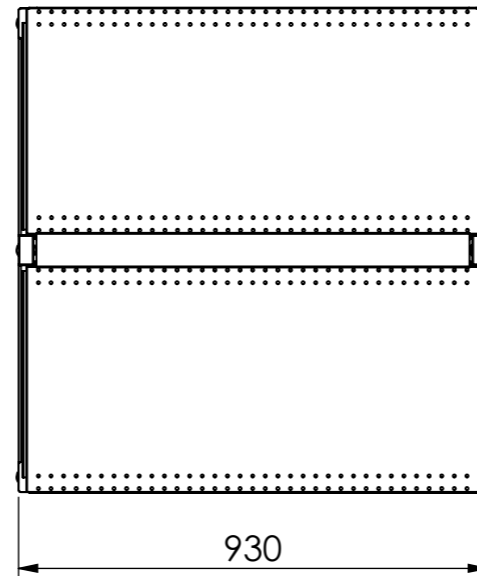
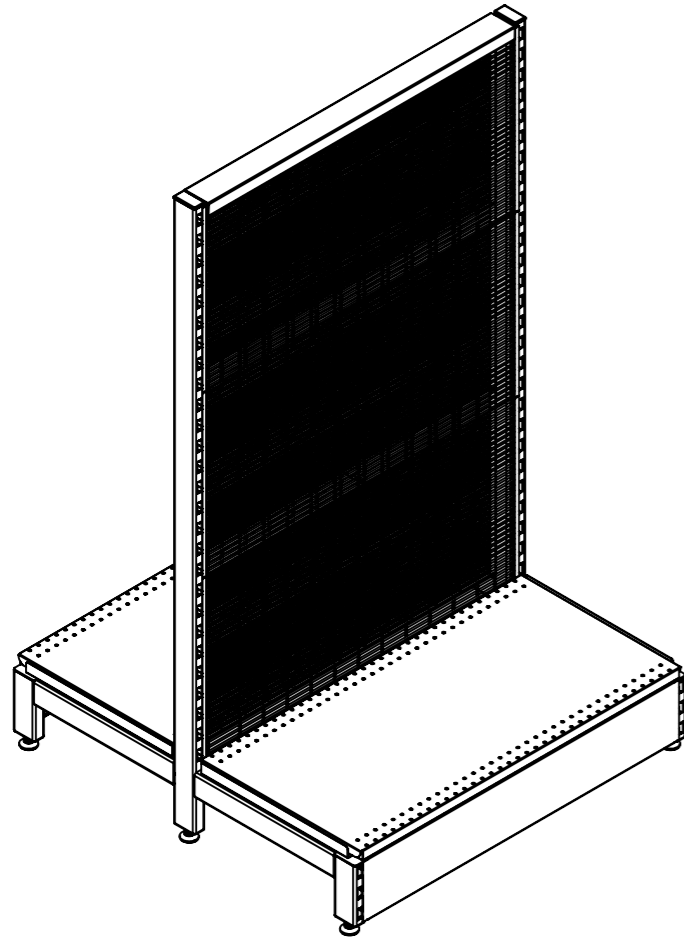

T 03 8787 3000 F 03 8787 3025  
 48-58 Cyber Loop, Dandenong South  
 VIC 3175 (AUSTRALIA)

© COPYRIGHT. This drawing is the exclusive property of Associated Projects Pty Ltd. It is subject to protection and is strictly confidential. Reproduction in whole or in part is prohibited without obtaining prior permission in writing from the proprietor.

Rev	Date	Description

ALL DIMENSIONS IN (mm)  
 UNLESS OTHERWISE SPECIFIED  
 BREAK ALL SHARP EDGES

TOLERANCES  
 (BEFORE PAINTING  
 & AFTER PLATING)  
 X ± 1.00  
 X.X ± 0.50  
 X.XX ± 0.10  
 ANGLES ± 0.5°

A02- CLIENT  
 CLIENT: -  
 PROJ. NO.: TBA  
 FINISH: P/C MATTE BLACK  
 MAT'L: Material <not specified>  
 Page 2

START BAY - DOUBLE SIDED GONDOLA-WIRE MESH  
 W900 x H1515 x D450

PRODUCT CODE: **RFA2050**  
 Date: 12/07/2024  
 Drawn by: DH  
 Checked by: NP

DO NOT SCALE  
 Scale@A3 1:15

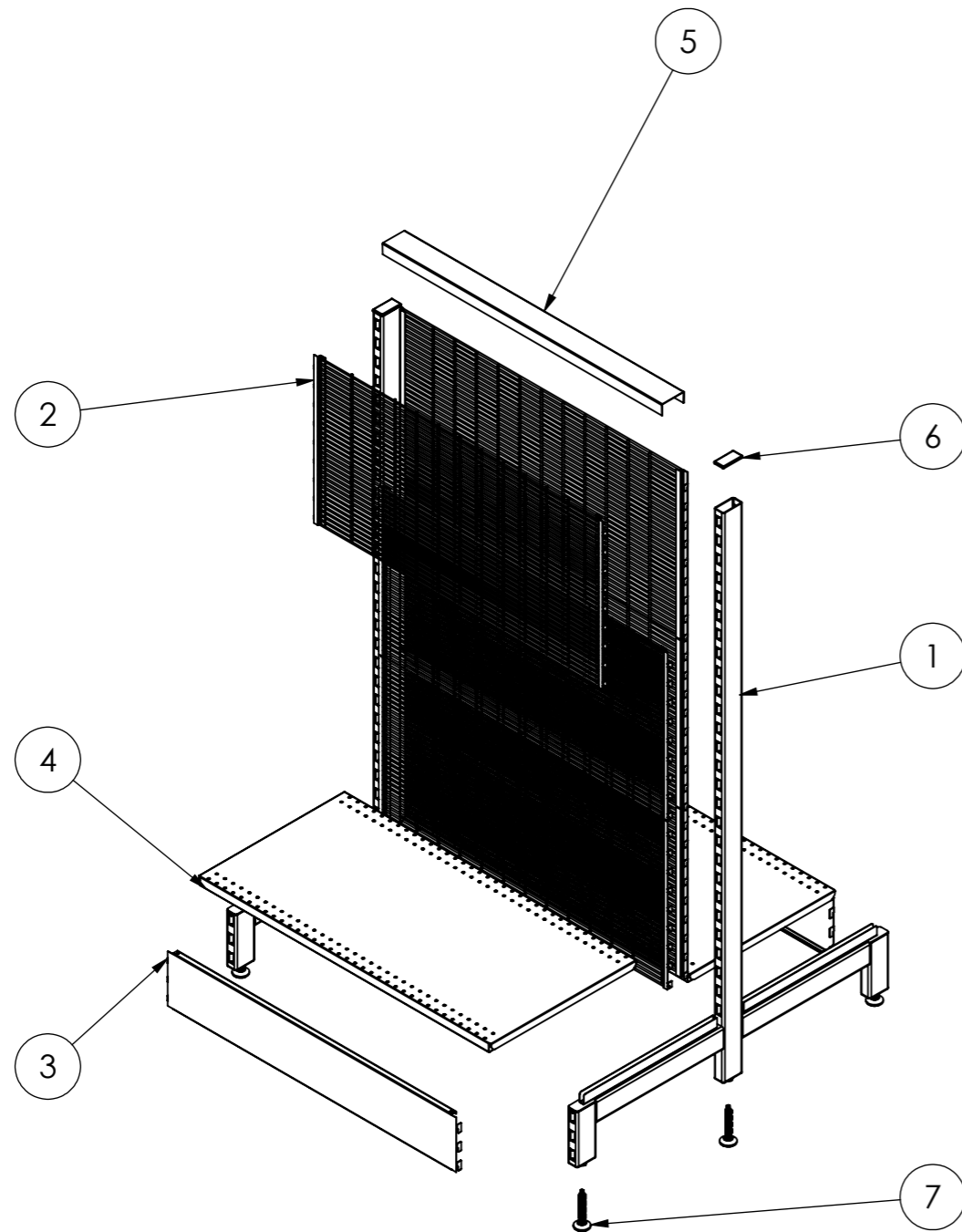

ITEM NO.	PRODUCT CODE	DESCRIPTION	FINISH	QTY.
1	RFA2331	POST - GONDOLA - DOUBLE SIDED - H1515XD900	P/C MATTE BLACK	2
2	RFA2359	WIRE MESH PANEL - CLIP IN PANEL - W900XH450	P/C MATTE BLACK	6
3	RFA2322	900W X 150H SKIRT	P/C MATTE BLACK	2
4	RFA0411	SHELF - W900XD450 - W/. DOUBLE STIFFENER	P/C MATTE BLACK	2
5	RFA2334	TOP CAP - W900XH30 - W/. H30 RETURN FOLDS	P/C MATTE BLACK	1
6	-	PLASTIC ENDCAP	BLACK	2
7	-	ADJ. FEET OD38_M12_H70THD	RAW	6



T 03 8787 3000 F 03 8787 3025  
48-58 Cyber Loop, Dandenong South  
VIC 3175 (AUSTRALIA)

© COPYRIGHT. This drawing is the exclusive property of Associated Projects Pty Ltd. It is subject to protection and is strictly confidential. Reproduction in whole or in part is prohibited without obtaining prior permission in writing from the proprietor.

Rev	Date	Description

ALL DIMENSIONS IN (mm)  
UNLESS OTHERWISE SPECIFIED  
BREAK ALL SHARP EDGES

TOLERANCES  
(BEFORE PAINTING  
& AFTER PLATING)  
X ± 1.00  
X.X ± 0.50  
X.XX ± 0.10  
ANGLES ± 0.5°

**A03- EXPLODED VIEW**  
CLIENT: -  
PROJ. NO.: TBA  
FINISH: P/C MATTE BLACK  
MAT'L: Material <not specified>  
Page 3

**START BAY - DOUBLE SIDED GONDOLA-WIRE MESH**  
W900 x H1515 x D450

PRODUCT CODE: **RFA2050**

Date: 12/07/2024

Drawn by DH

Checked by NP

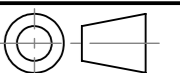

DO NOT SCALE

Scale@A3 1:15