



**This product is an Add Bay**

\*Supplied with (1) post only  
 \*Add Bay connects to the post of the neighboring Bay



T 03 8787 3000 F 03 8787 3025  
 48-58 Cyber Loop, Dandenong South  
 VIC 3175 (AUSTRALIA)

© COPYRIGHT. This drawing is the exclusive property of Associated Projects Pty Ltd. It is subject to protection and is strictly confidential. Reproduction in whole or in part is prohibited without obtaining prior permission in writing from the proprietor.

Rev	Date	Description

ALL DIMENSIONS IN (mm)  
 UNLESS OTHERWISE SPECIFIED  
 BREAK ALL SHARP EDGES

TOLERANCES  
 (BEFORE PAINTING  
 & AFTER PLATING)  
 X ± 1.00  
 X.X ± 0.50  
 X.XX ± 0.10  
 ANGLES ± 0.5°

**A01- RENDER**  
**CLIENT: -**  
**PROJ. NO.: TBA**  
**FINISH: P/C MATTE BLACK**  
**MAT'L: Material <not specified>**  
**Page 1**

**ADD BAY - DOUBLE SIDED GONDOLA-WIRE MESH**  
**W600 x H1515 x D450**

<b>PRODUCT CODE: RFA2049</b>		
Date:	11/07/2024	
Drawn by	DH	DO NOT SCALE
Checked by	NP	Scale@A3 1:20

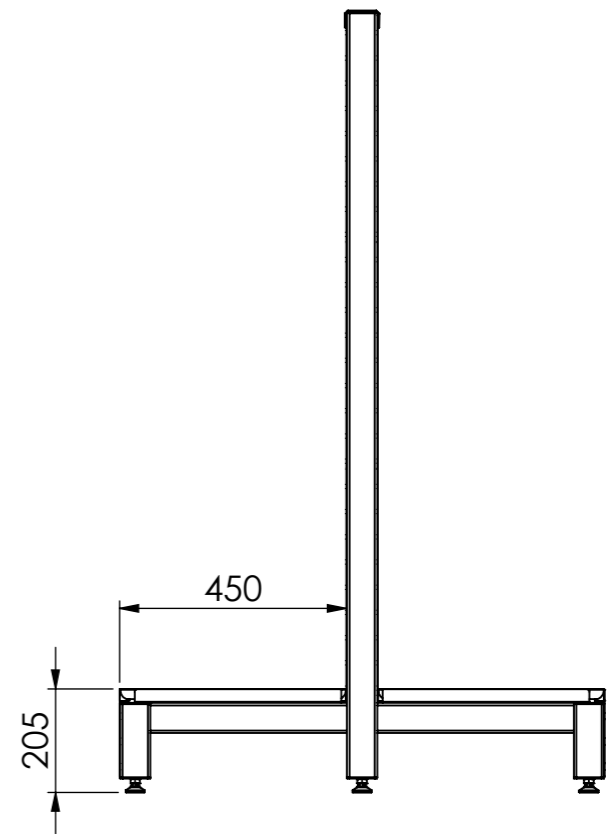
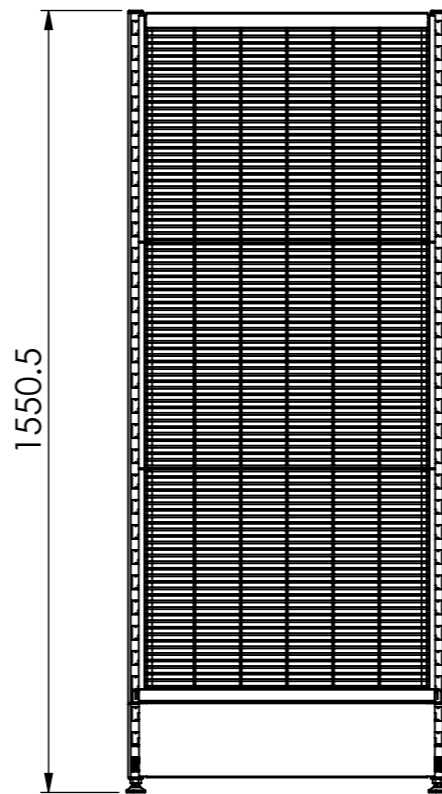
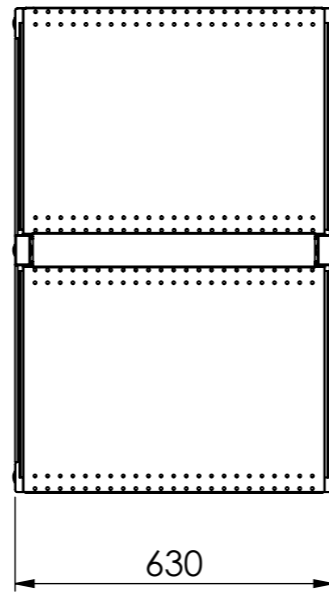
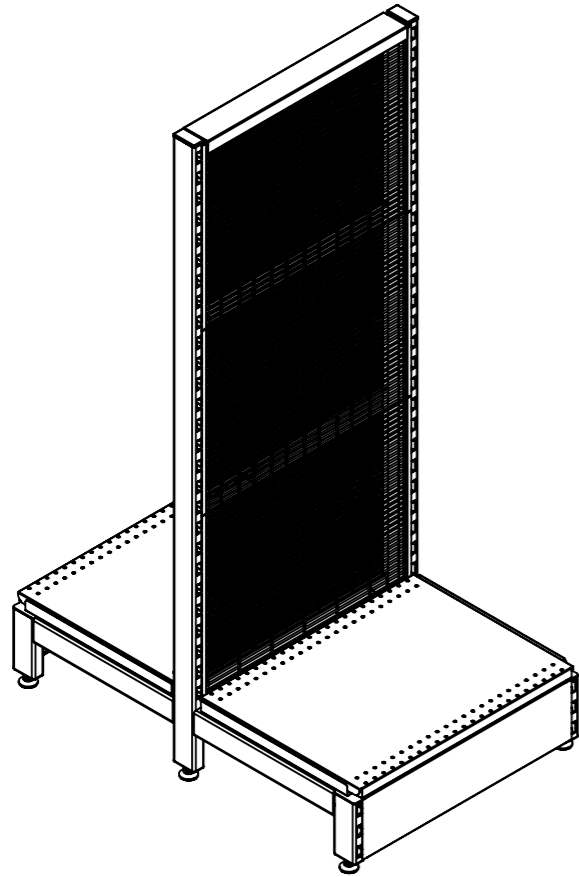

T 03 8787 3000 F 03 8787 3025  
 48-58 Cyber Loop, Dandenong South  
 VIC 3175 (AUSTRALIA)

© COPYRIGHT. This drawing is the exclusive property of Associated Projects Pty Ltd. It is subject to protection and is strictly confidential. Reproduction in whole or in part is prohibited without obtaining prior permission in writing from the proprietor.

Rev	Date	Description

ALL DIMENSIONS IN (mm)  
 UNLESS OTHERWISE SPECIFIED  
 BREAK ALL SHARP EDGES

TOLERANCES  
 (BEFORE PAINTING  
 & AFTER PLATING)  
 X ± 1.00  
 X.X ± 0.50  
 X.XX ± 0.10  
 ANGLES ± 0.5°

A02- CLIENT  
 CLIENT: -  
 PROJ. NO.: TBA  
 FINISH: P/C MATTE BLACK  
 MAT'L: Material <not specified>  
 Page 2

ADD BAY -DOUBLE SIDED GONDOLA-WIRE MESH W600 x H1515 x D450		
PRODUCT CODE: <b>RFA2049</b>		
Date: 11/07/2024		
Drawn by: DH	DO NOT SCALE	
Checked by: NP	Scale@A3 1:15	

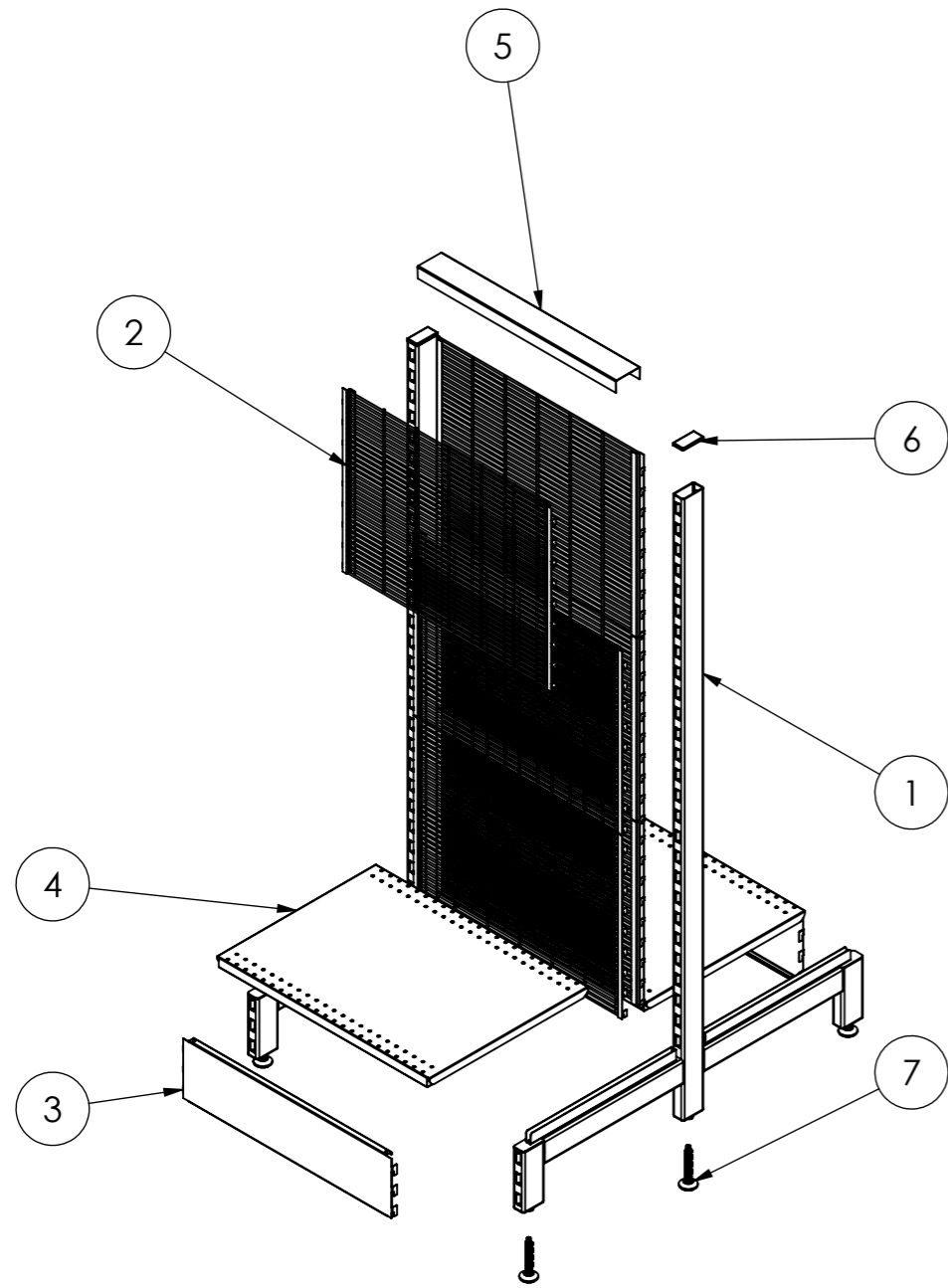

ITEM NO.	PRODUCT CODE	DESCRIPTION	FINISH	QTY.
1	RFA2331	POST - GONDOLA - DOUBLE SIDED - H1515XD900	P/C MATTE BLACK	2
2	RFA2757	WIRE MESH PANEL - CLIP IN PANEL - W1200XH300	P/C PEARL WHITE	6
3	RFA2321	W600 X H150 SKIRT	P/C MATTE BLACK	2
4	RFA0408	SHELF - W600XD450 - W/. DOUBLE STIFFENER	P/C MATTE BLACK	2
5	RFA2333	TOP CAP - W600XH30 - W/. H30 RETURN FOLDS	P/C MATTE BLACK	1
6	-	PLASTIC ENDCAP	BLACK	2
7	-	ADJ. FEET OD38_M12_H70THD	RAW	6



T 03 8787 3000 F 03 8787 3025  
48-58 Cyber Loop, Dandenong South  
VIC 3175 (AUSTRALIA)

© COPYRIGHT. This drawing is the exclusive property of Associated Projects Pty Ltd. It is subject to protection and is strictly confidential. Reproduction in whole or in part is prohibited without obtaining prior permission in writing from the proprietor.

Rev	Date	Description

ALL DIMENSIONS IN (mm)  
UNLESS OTHERWISE SPECIFIED  
BREAK ALL SHARP EDGES

TOLERANCES  
(BEFORE PAINTING  
& AFTER PLATING)  
X ± 1.00  
X.X ± 0.50  
X.XX ± 0.10  
ANGLES ± 0.5°

A03- EXPLODED VIEW

CLIENT: -

PROJ. NO.: TBA

FINISH: P/C MATTE BLACK

MAT'L: Material <not specified>

Page 3

ADD BAY - DOUBLE SIDED GONDOLA-WIRE MESH  
W600 x H1515 x D450

PRODUCT CODE: **RFA2049**

Date: 11/07/2024

Drawn by DH

Checked by NP

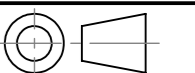

DO NOT SCALE

Scale@A3 1:15