

T 03 8787 3000 F 03 8787 3025  
 48-58 Cyber Loop, Dandenong South  
 VIC 3175 (AUSTRALIA)

© COPYRIGHT. This drawing is the exclusive property of Associated Projects Pty Ltd. It is subject to protection and is strictly confidential. Reproduction in whole or in part is prohibited without obtaining prior permission in writing from the proprietor.

Rev	Date	Description

ALL DIMENSIONS IN (mm)  
 UNLESS OTHERWISE SPECIFIED  
 BREAK ALL SHARP EDGES

TOLERANCES  
 (BEFORE PAINTING  
 & AFTER PLATING)  
 X ± 1.00  
 X.X ± 0.50  
 X.XX ± 0.10  
 ANGLES ± 0.5°

A01- RENDER

CLIENT: -

PROJ. NO.: TBA

FINISH: P/C MATTE BLACK

MAT'L: "SW-  
 Material@@W1200\_NON  
 Page @Part2/SLDPRT"

START BAY -WALL BAY-SOFTSHELL -  
 W1200XH2400XD450 -NON PERFORATED

PRODUCT CODE: **RFA2012**

Date: 4/10/2023

Drawn by DH

Checked by NP

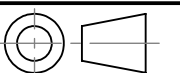

DO NOT SCALE

Scale@A3 1:20

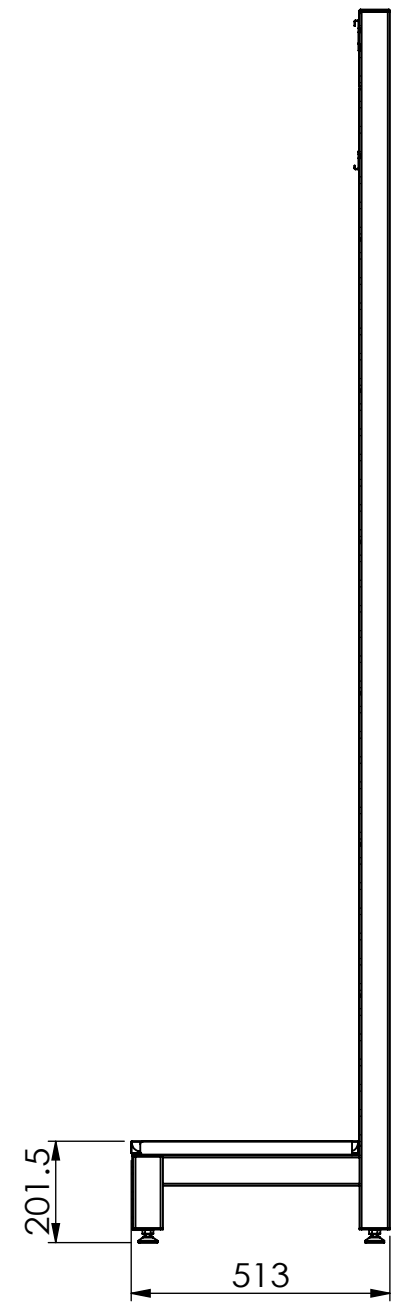
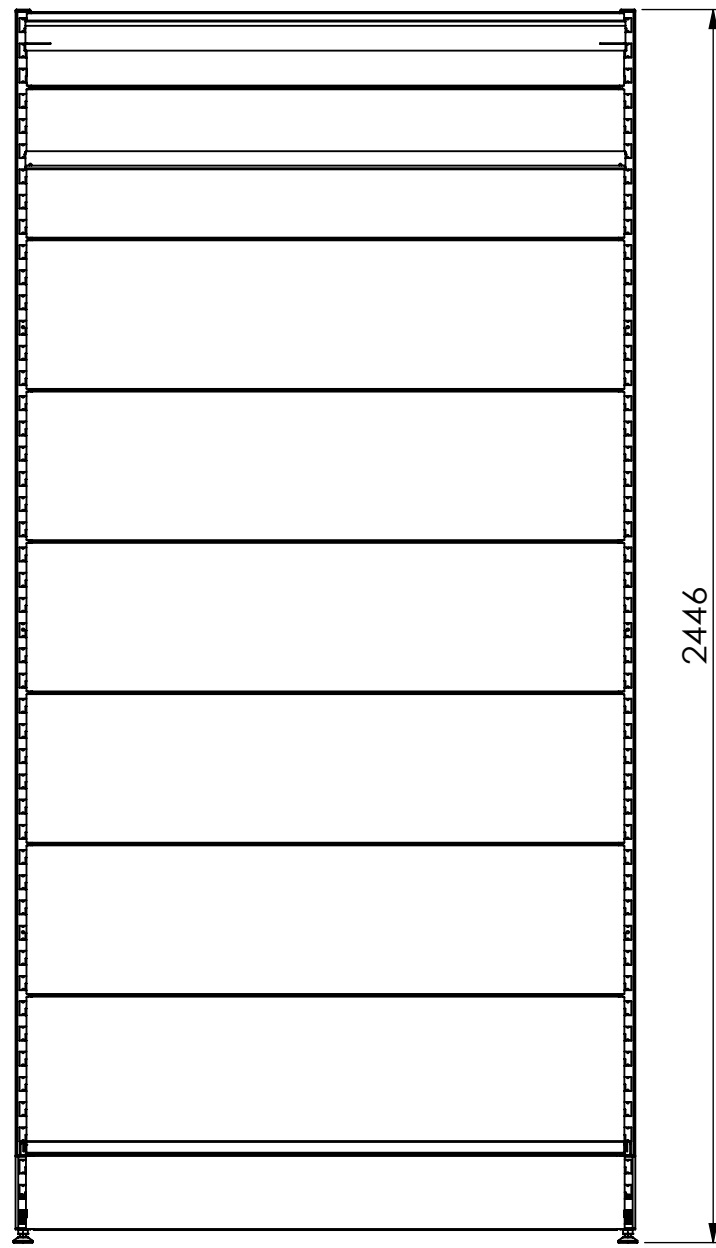
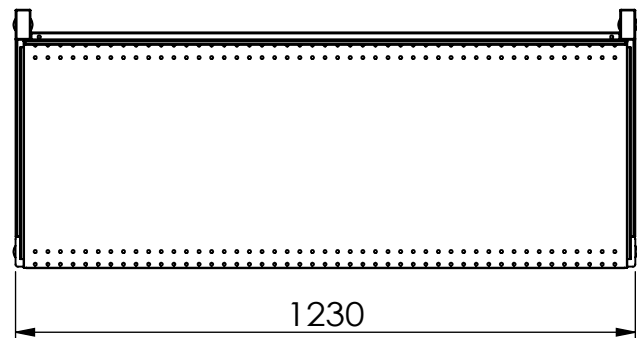
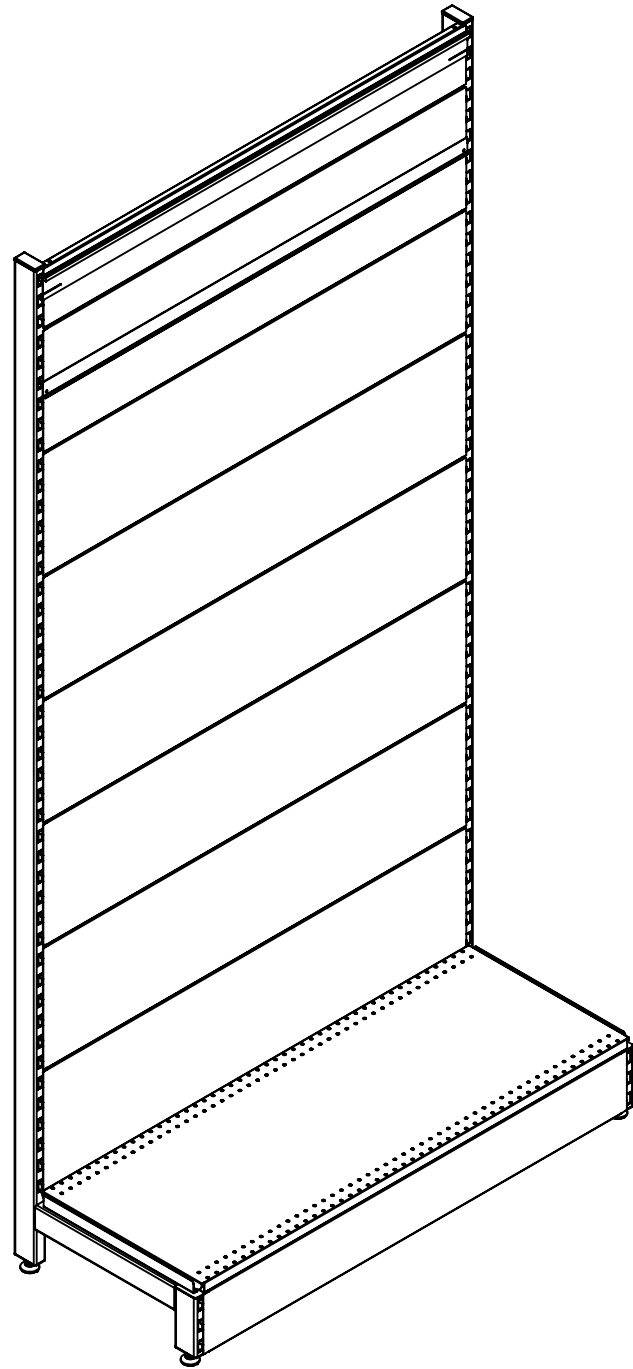

T 03 8787 3000 F 03 8787 3025  
 48-58 Cyber Loop, Dandenong South  
 VIC 3175 (AUSTRALIA)

© COPYRIGHT. This drawing is the exclusive property of Associated Projects Pty Ltd. It is subject to protection and is strictly confidential. Reproduction in whole or in part is prohibited without obtaining prior permission in writing from the proprietor.

Rev	Date	Description

ALL DIMENSIONS IN (mm)  
 UNLESS OTHERWISE SPECIFIED  
 BREAK ALL SHARP EDGES

TOLERANCES  
 (BEFORE PAINTING  
 & AFTER PLATING)  
 X ± 1.00  
 X.X ± 0.50  
 X.XX ± 0.10  
 ANGLES ± 0.5°

A02- CLIENT  
 CLIENT: -  
 PROJ. NO.: TBA  
 FINISH: P/C MATTE BLACK  
 MAT'L: "SW-  
 Material@@W1200\_NON  
 Page @PartZSLDPRT"

START BAY -WALL BAY-SOFTSHELL - W1200XH2400XD450 -NON PERFORATED		
PRODUCT CODE: <b>RFA2012</b>	Date: 4/10/2023	
Drawn by: DH	Checked by: NP	DO NOT SCALE
Scale@A3 1:15		

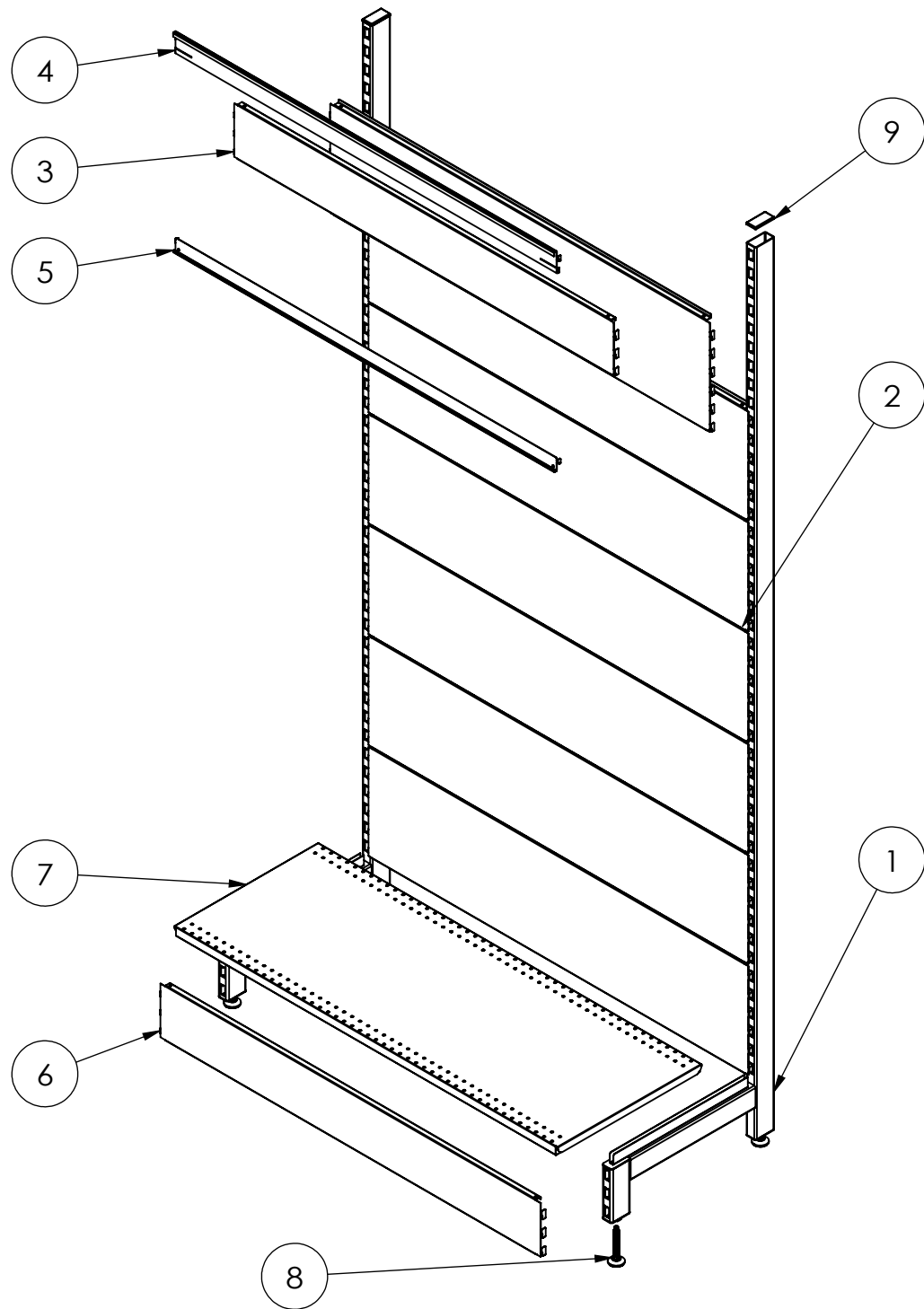

ITEM NO.	PRODUCT CODE	DESCRIPTION	FINISH	QTY.
1	RFA2302	-	P/C MATTE BLACK	2
2	RFA2314	CLIP IN PANEL - W1200XH300 - NON PERFORATED	P/C MATTE BLACK	7
3	RFA2311	CLIP IN PANEL - W1200XH150 - NON PERFORATED	P/C MATTE BLACK	1
4	RFA2328	SIGNAGE SUPPORT (SLIDER) BRACKET - W1200 - TOP BRACKET	P/C MATTE BLACK	1
5	RFA2329	SIGNAGE SUPPORT (SLIDER) BRACKET - W1200 - BOTTOM BRACKET	P/C MATTE BLACK	1
6	RFA2323	1200W X 150H SKIRT	P/C MATTE BLACK	1
7	RFA0414	SHELF - W1200XD450 - W/. DOUBLE STIFFENER	P/C MATTE BLACK	1
8	-	ADJ. FEET OD38_M12_H70THD	RAW	4
9	-	PLASTIC ENDCAP	BLACK	2



T 03 8787 3000 F 03 8787 3025  
48-58 Cyber Loop, Dandenong South  
VIC 3175 (AUSTRALIA)

© COPYRIGHT. This drawing is the exclusive property of Associated Projects Pty Ltd. It is subject to protection and is strictly confidential. Reproduction in whole or in part is prohibited without obtaining prior permission in writing from the proprietor.

Rev	Date	Description

ALL DIMENSIONS IN (mm)  
UNLESS OTHERWISE SPECIFIED  
BREAK ALL SHARP EDGES

TOLERANCES  
(BEFORE PAINTING  
& AFTER PLATING)  
X ± 1.00  
X.X ± 0.50  
X.XX ± 0.10  
ANGLES ± 0.5°

A03- EXPLODED VIEW

CLIENT: -

PROJ. NO.: TBA

FINISH: P/C MATTE BLACK

MAT'L: "SW-  
Material@@W1200\_NON  
Page @Part2SLDPRT"

START BAY -WALL BAY-SOFTSHELL -  
W1200XH2400XD450 -NON PERFORATED

PRODUCT CODE: **RFA2012**

Date: 4/10/2023

Drawn by DH

Checked by NP

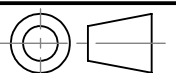

DO NOT SCALE

Scale@A3 1:15