

FINISH: P/C PEARL WHITE

**AP ASSOCIATED PROJECTS** COMMERCIAL BUILDERS,  
PROJECT MANAGERS,  
PLANNERS & DESIGNERS

T 03 8787 3000 F 03 8787 3025  
48-58 Cyber Loop, Dandenong South VIC 3175

Rev	Date	Description

ALL DIMENSIONS IN (mm)  
UNLESS OTHERWISE SPECIFIED  
BREAK ALL SHARP EDGES

TOLERANCES  
(BEFORE PAINTING  
& AFTER PLATING)  
X ± 1.00  
X.X ± 0.50  
X.XX ± 0.10  
ANGLES ± 0.5°

A01- RENDER

CLIENT: RFA

PROJ. NO.: TBA

PART NO.: --

Revision --

Page 1

START BAY - DOUBLE SIDED GONDOLA - NON  
PERFORATED - W/ SKIRT DRAWER - SPECIAL

W600 x H2115 x D270

PRODUCT CODE: **RFA1526**

Date: 10/07/2024

Drawn by PS

Checked by --

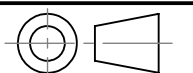

DO NOT SCALE

Scale@A3 1:20

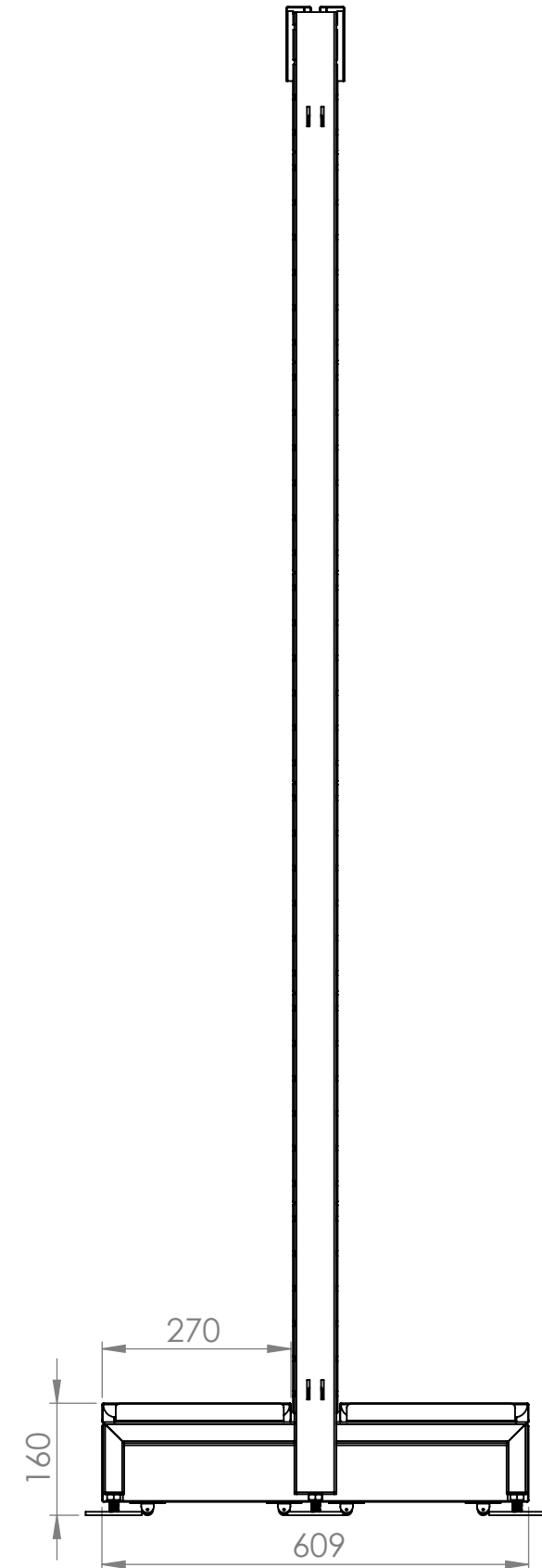
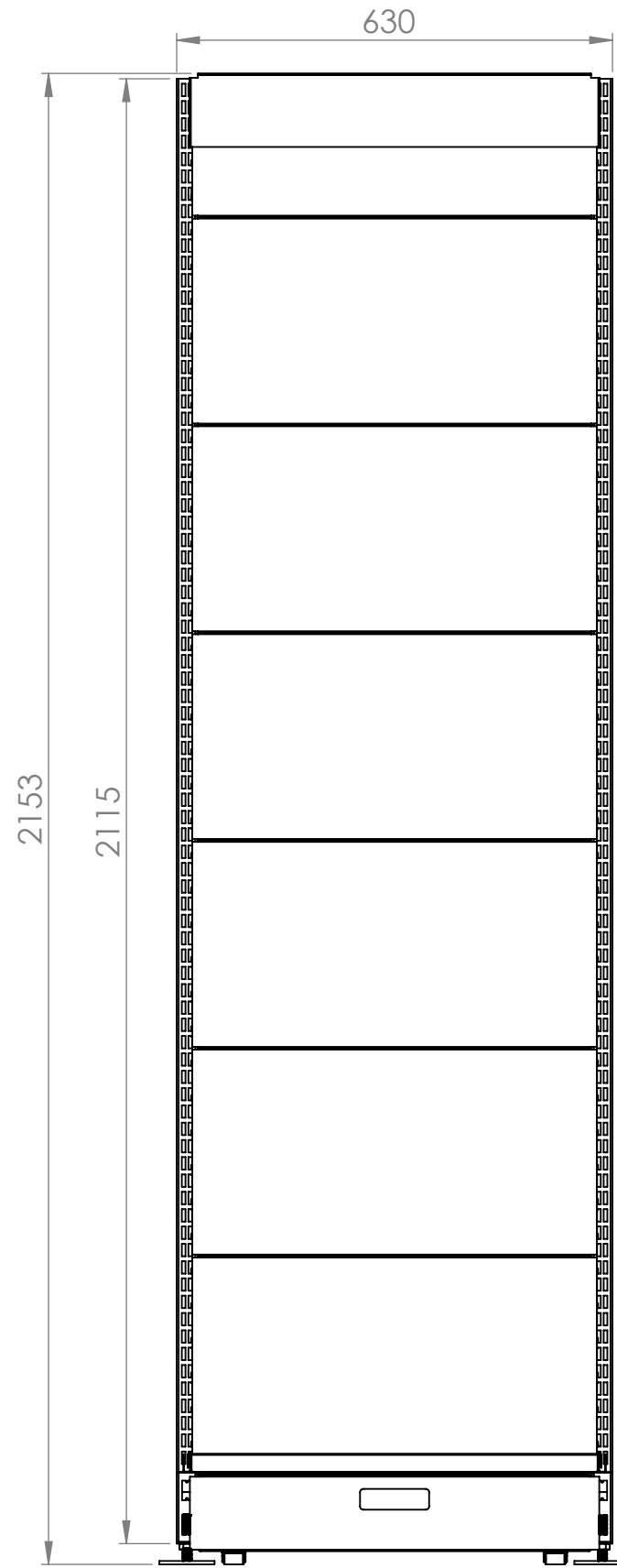
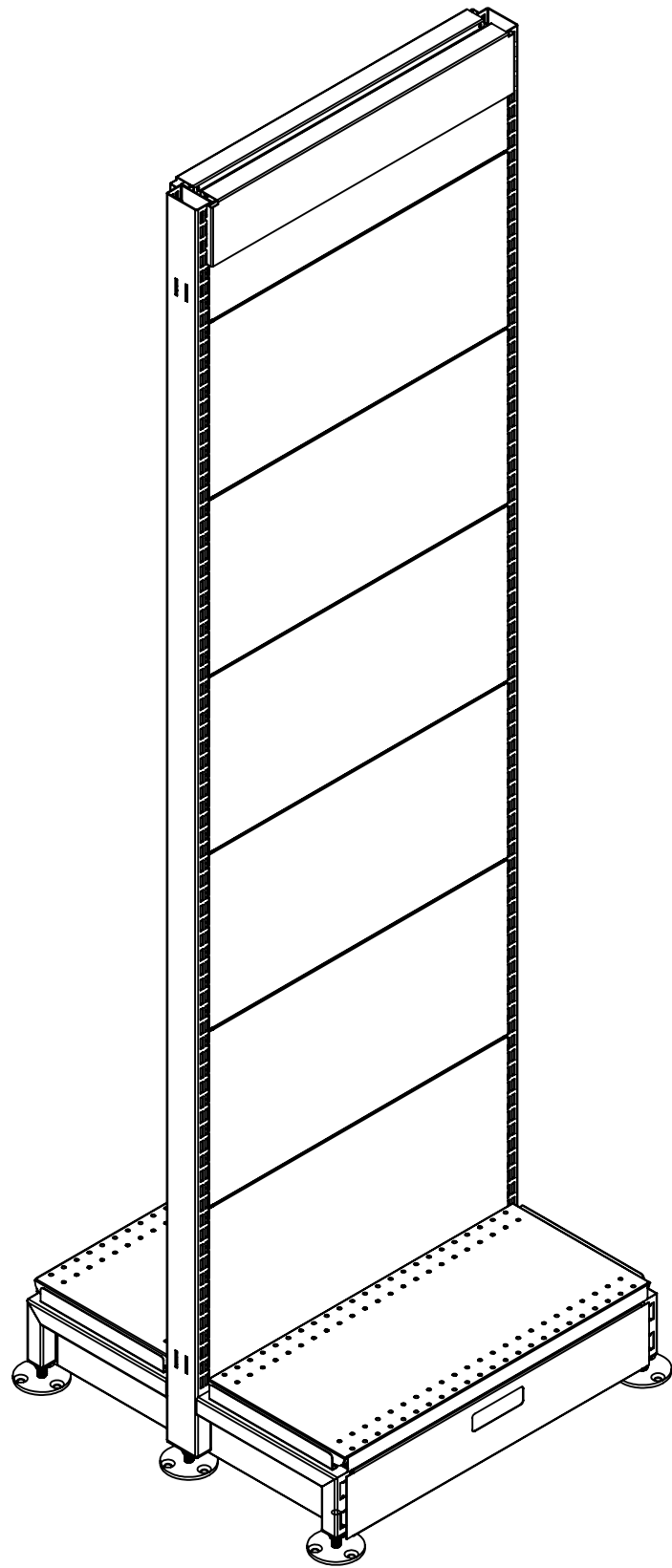

Rev	Date	Description

ALL DIMENSIONS IN (mm)  
UNLESS OTHERWISE SPECIFIED  
BREAK ALL SHARP EDGES

TOLERANCES  
(BEFORE PAINTING  
& AFTER PLATING)  
X ± 1.00  
X.X ± 0.50  
X.XX ± 0.10  
ANGLES ± 0.5°

**A02- DIMENSIONS**

CLIENT: RFA  
PROJ. NO.: TBA  
PART NO.: --  
Revision --  
Page 2

START BAY - DOUBLE SIDED GONDOLA - NON  
PERFORATED - W/ SKIRT DRAWER - SPECIAL  
W600 x H2115 x D270

PRODUCT CODE: **RFA1526**

Date: 10/07/2024

Drawn by PS

Checked by --

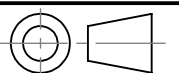

DO NOT SCALE

Scale@A3 1:10

ITEM NO.	PartNo	DESCRIPTION	QTY.
1	RFA1152	2115mm (H) WALL BAY POST	2
2	RFA1153	BOLT DOWN LEVELLER DIA 80-3 HOLE	6
3	RFA1106	CLIP IN PANEL - 600(W) X 300(H) - NON PERFORATED - PEARL WHITE	12
4	RFA1105	CLIP IN PANEL - 600(W) X 200(H) - NON PERFORATED - PEARL WHITE	2
5	RFA1114	SKIRT DRAWER BOX	2
6	RFA0400	600mm(W)x270mm(D) STEEL SHELF	2
7	RFA1123	SNAP IN TOP CAP_BLACK	2
8	RFA1137	POST - SPACER BRACKET	2

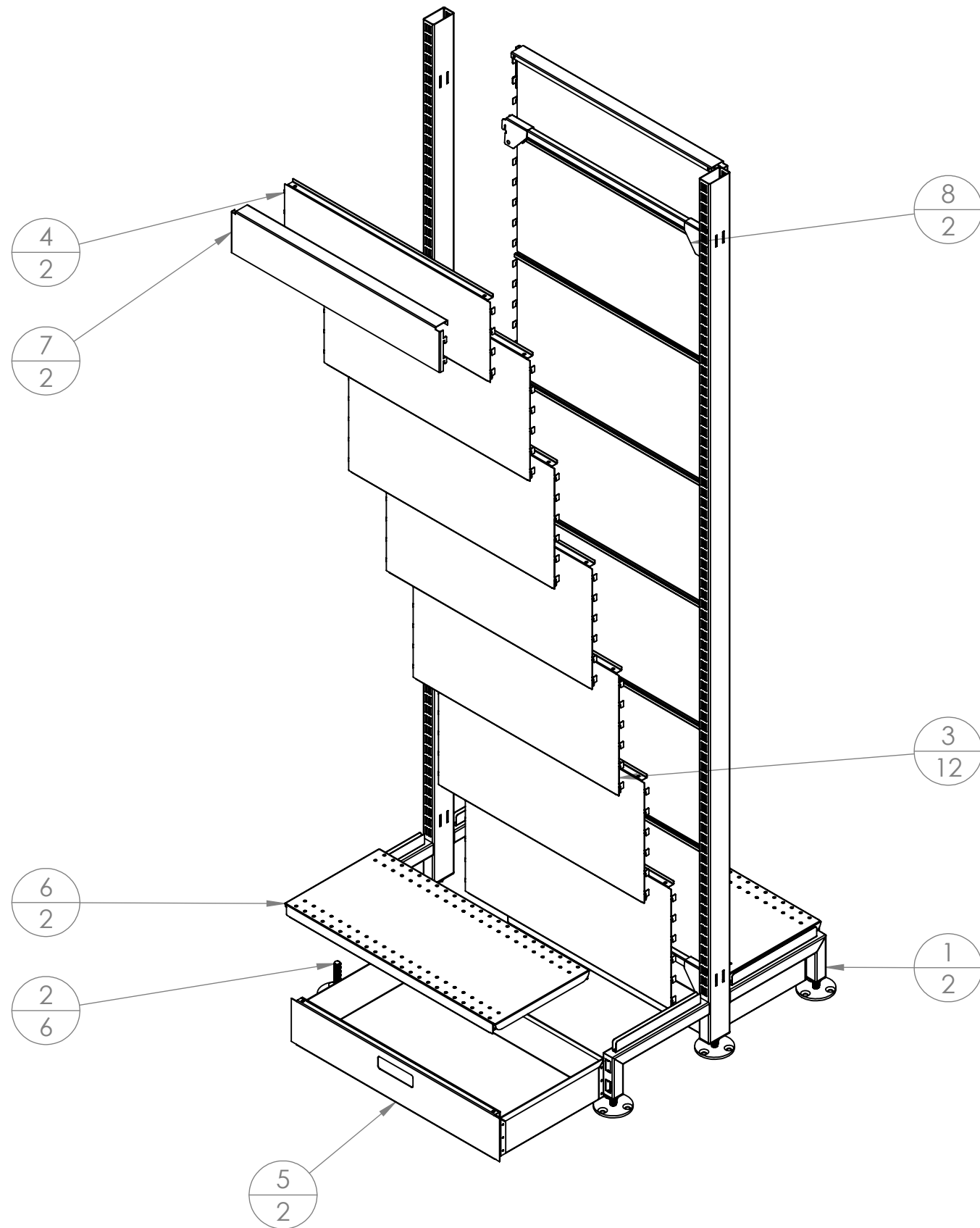

Rev	Date	Description

ALL DIMENSIONS IN (mm)  
UNLESS OTHERWISE SPECIFIED  
BREAK ALL SHARP EDGES

TOLERANCES  
(BEFORE PAINTING  
& AFTER PLATING)  
X ± 1.00  
X.X ± 0.50  
X.XX ± 0.10  
ANGLES ± 0.5°

A03- EXPLODED

CLIENT: RFA  
PROJ. NO.: TBA  
PART NO.: --  
Revision --  
Page 3

START BAY - DOUBLE SIDED GONDOLA - NON PERFORATED - W/ SKIRT DRAWER - SPECIAL  
W600 x H2115 x D270

PRODUCT CODE: **RFA1526**

Date: 10/07/2024

Drawn by PS

Checked by --

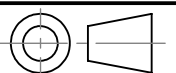

DO NOT SCALE

Scale@A3 1:10