

FINISH: P/C PEARL WHITE

AP ASSOCIATED PROJECTS COMMERCIAL BUILDERS,
PROJECT MANAGERS,
PLANNERS & DESIGNERS

T 03 8787 3000 F 03 8787 3025
48-58 Cyber Loop, Dandenong South VIC 3175

Rev	Date	Description

ALL DIMENSIONS IN (mm)
UNLESS OTHERWISE SPECIFIED
BREAK ALL SHARP EDGES

TOLERANCES
(BEFORE PAINTING
& AFTER PLATING)
X ± 1.00
X.X ± 0.50
X.XX ± 0.10
ANGLES ± 0.5°

A01- RENDER

CLIENT: RFA

PROJ. NO.: TBA

PART NO.: --

Revision --

Page 1

START BAY - DOUBLE SIDED GONDOLA - NON
PERFORATED - SPECIAL

W600 x H2115 x D270

PRODUCT CODE: **RFA1524**

Date: 9/07/2024

Drawn by PS

Checked by --

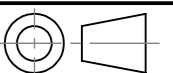

DO NOT SCALE

Scale@A3 1:20

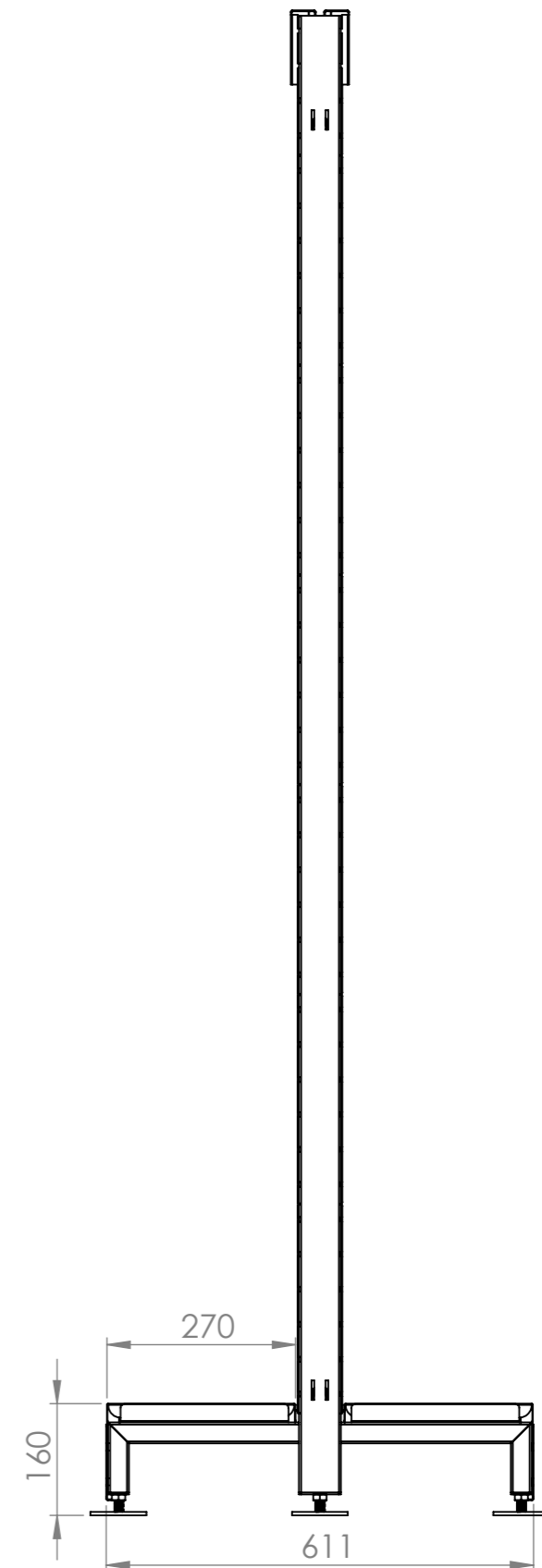
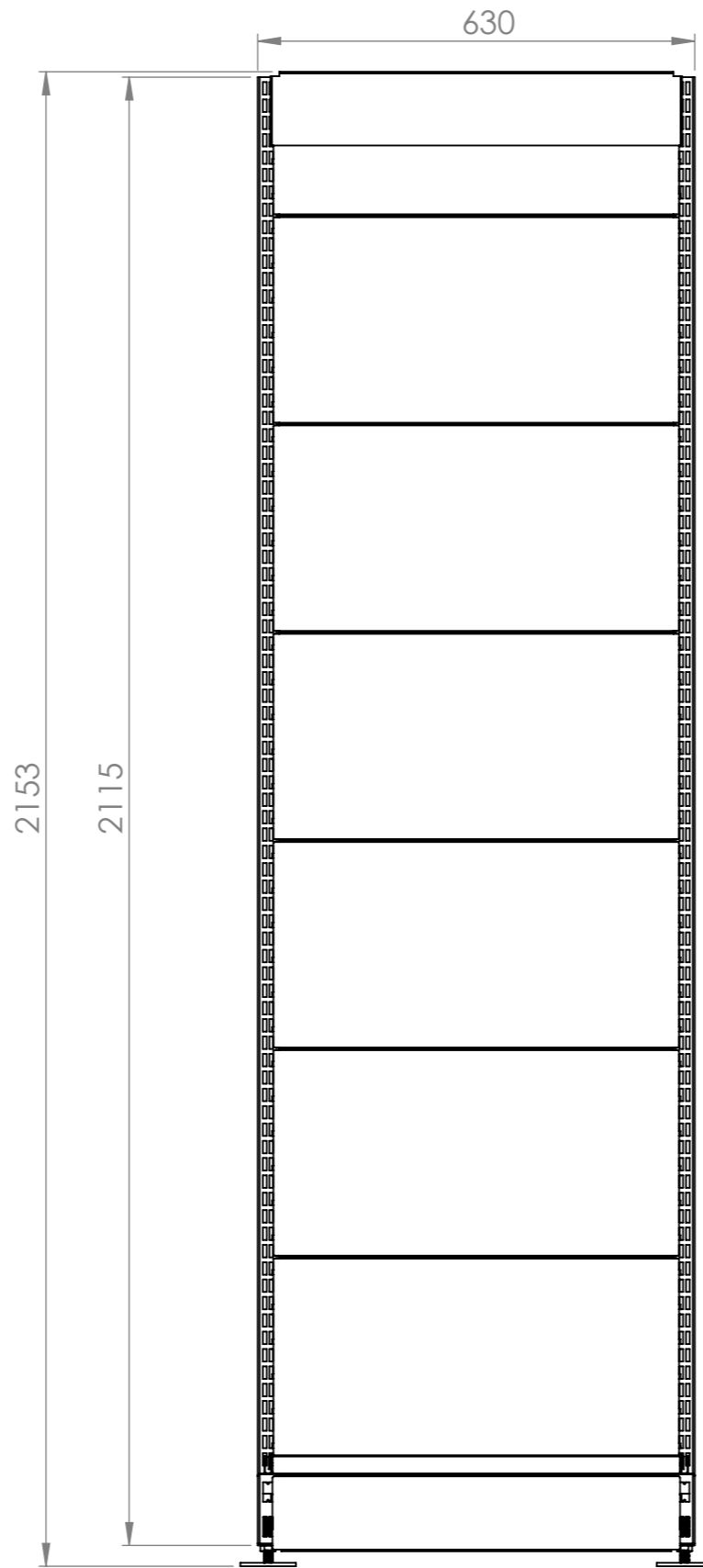
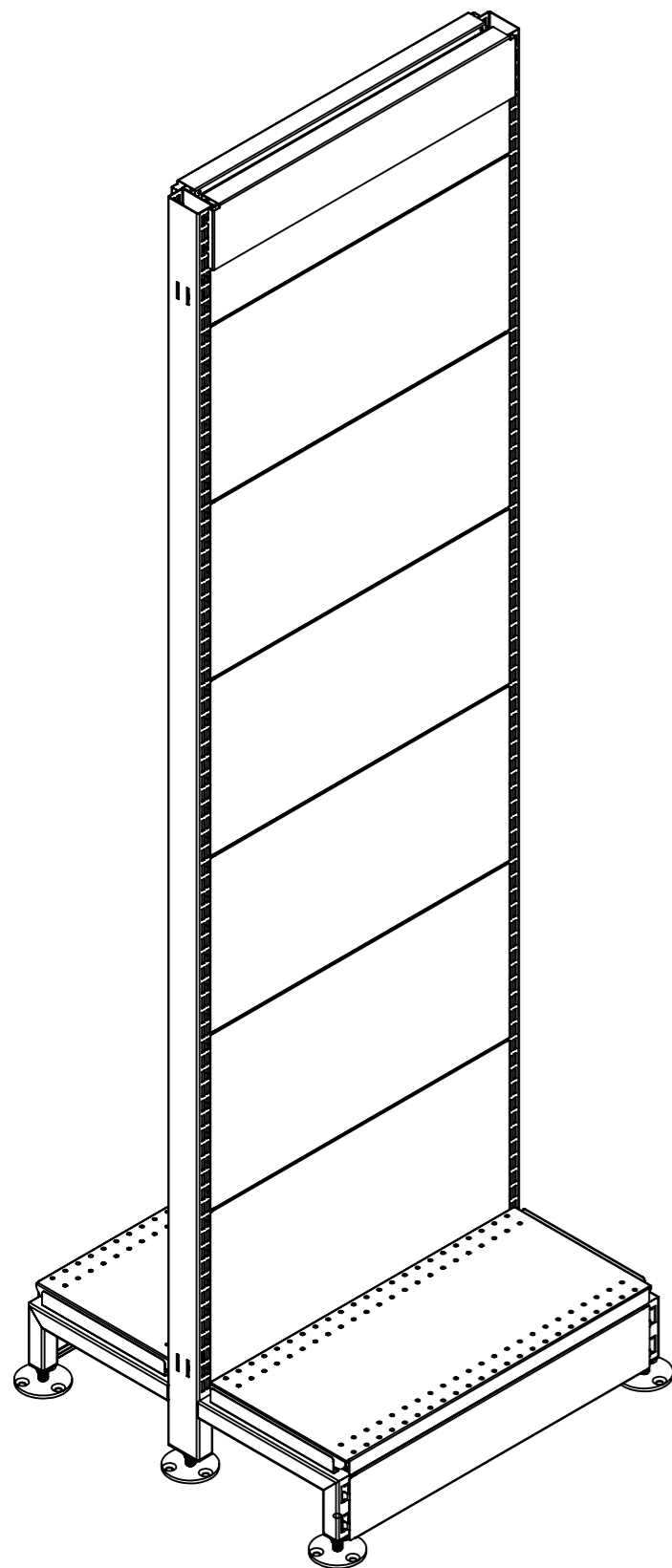

Rev	Date	Description

ALL DIMENSIONS IN (mm)
UNLESS OTHERWISE SPECIFIED
BREAK ALL SHARP EDGES

TOLERANCES
(BEFORE PAINTING
& AFTER PLATING)
X ± 1.00
X.X ± 0.50
X.XX ± 0.10
ANGLES ± 0.5°

A02- DIMENSIONS

CLIENT: RFA
PROJ. NO.: TBA
PART NO.: --
Revision --
Page 2

START BAY - DOUBLE SIDED GONDOLA - NON PERFORATED - SPECIAL

W600 x H2115 x D270

PRODUCT CODE: **RFA1524**

Date: 9/07/2024

Drawn by PS

Checked by --

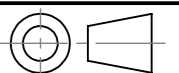

DO NOT SCALE

Scale@A3 1:10

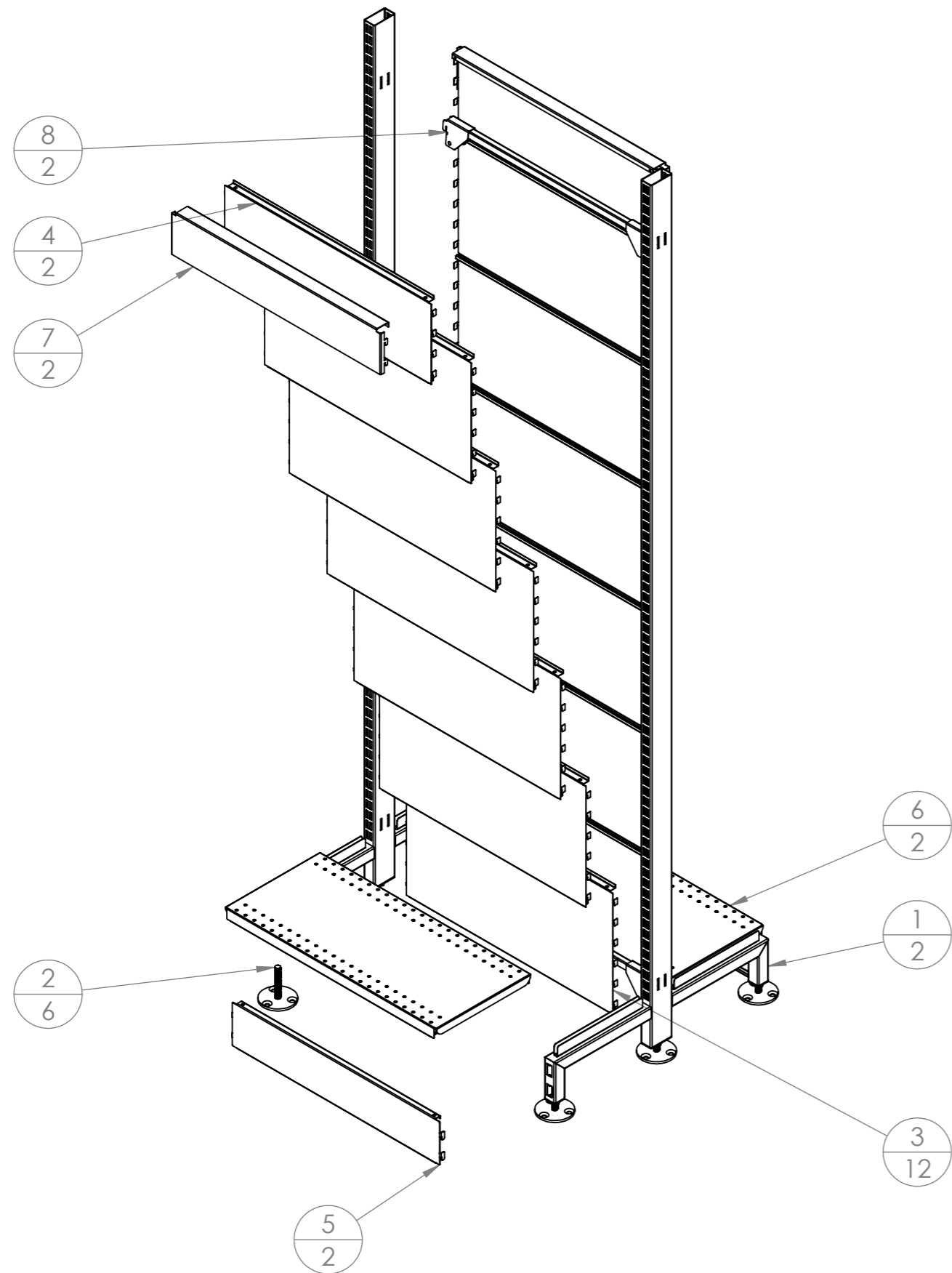

ITEM NO.	PartNo	DESCRIPTION	QTY.
1	RFA1152	2115mm (H) WALL BAY POST	2
2	RFA1153	BOLT DOWN LEVELLER DIA 80-3 HOLE	6
3	RFA1106	CLIP IN PANEL - 600(W) X 300(H) - NON PERFORATED - PEARL WHITE	12
4	RFA1105	CLIP IN PANEL - 600(W) X 200(H) - NON PERFORATED - PEARL WHITE	2
5	RFA1109	600 BOTTOM SKIRT	2
6	RFA0400	600mm(W)x270mm(D) STEEL SHELF	2
7	RFA1123	SNAP IN TOP CAP_BLACK	2
8	RFA1137	POST - SPACER BRACKET	2

Rev	Date	Description

ALL DIMENSIONS IN (mm)
UNLESS OTHERWISE SPECIFIED
BREAK ALL SHARP EDGES

TOLERANCES
(BEFORE PAINTING
& AFTER PLATING)
X ± 1.00
X.X ± 0.50
X.XX ± 0.10
ANGLES ± 0.5°

A03- EXPLODED

CLIENT: RFA
PROJ. NO.: TBA
PART NO.: --
Revision --
Page 3

START BAY - DOUBLE SIDED GONDOLA - NON PERFORATED - SPECIAL

W600 x H2115 x D270

PRODUCT CODE: **RFA1524**

Date: 9/07/2024

Drawn by PS

Checked by --

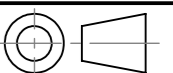

DO NOT SCALE

Scale@A3 1:10