

FINISH: P/C PEARL WHITE

**AP ASSOCIATED PROJECTS** COMMERCIAL BUILDERS,  
PROJECT MANAGERS,  
PLANNERS & DESIGNERS

T 03 8787 3000 F 03 8787 3025  
48-58 Cyber Loop, Dandenong South VIC 3175

Rev	Date	Description

ALL DIMENSIONS IN (mm)  
UNLESS OTHERWISE SPECIFIED  
BREAK ALL SHARP EDGES

TOLERANCES  
(BEFORE PAINTING  
& AFTER PLATING)  
X ± 1.00  
X.X ± 0.50  
X.XX ± 0.10  
ANGLES ± 0.5°

A01- RENDER

CLIENT: RFA

PROJ. NO.: TBA

PART NO.: --

Revision --

Page 1

ADD BAY - DOUBLE SIDED GONDOLA -  
PERFORATED - W/ SKIRT DRAWER - SPECIAL  
W900 x H2115 x D270

PRODUCT CODE: **RFA1523**

Date: 9/07/2024

Drawn by PS

Checked by --

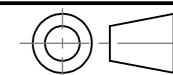

DO NOT SCALE

Scale@A3 1:20

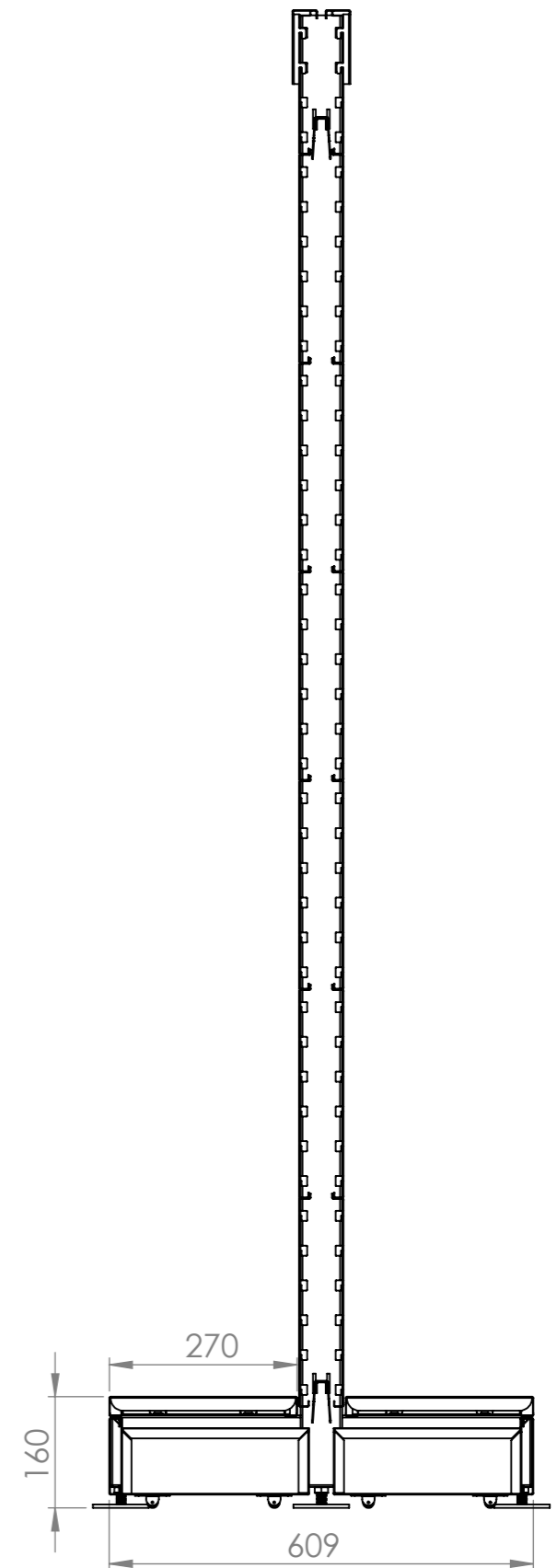
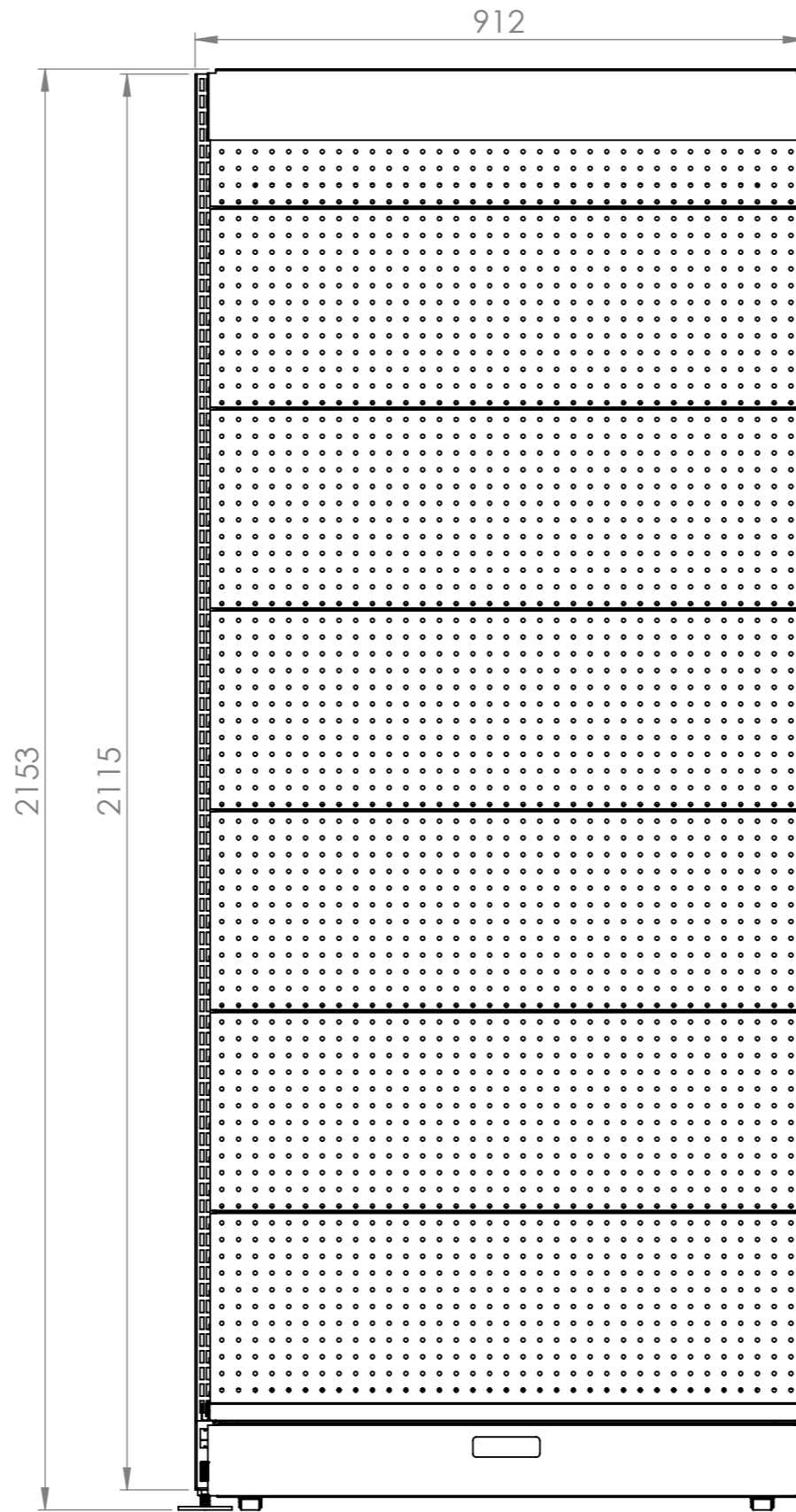
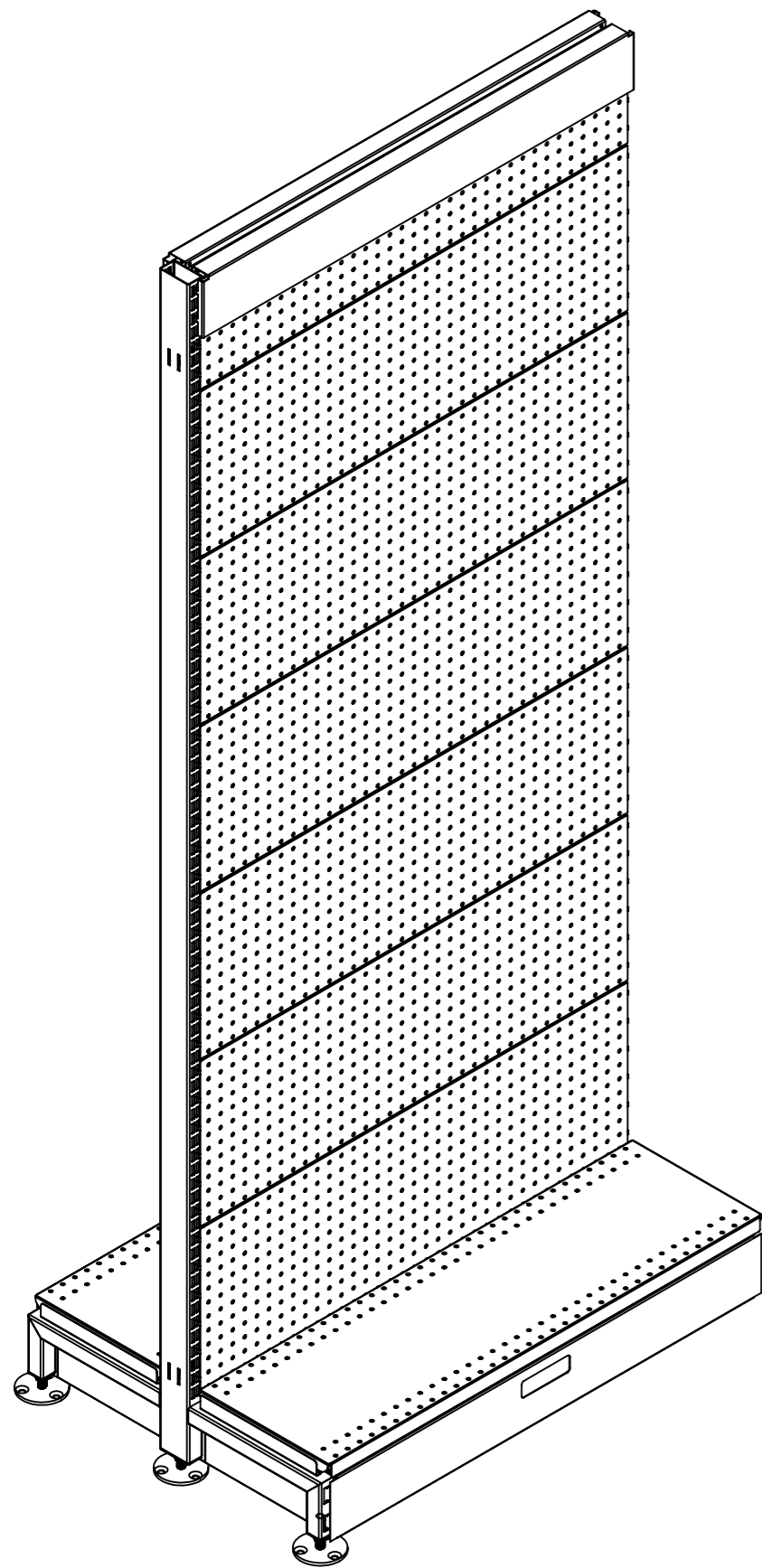

Rev	Date	Description

ALL DIMENSIONS IN (mm)  
UNLESS OTHERWISE SPECIFIED  
BREAK ALL SHARP EDGES

TOLERANCES  
(BEFORE PAINTING  
& AFTER PLATING)  
X ± 1.00  
X.X ± 0.50  
X.XX ± 0.10  
ANGLES ± 0.5°

**A02- DIMENSIONS**

CLIENT: RFA  
PROJ. NO.: TBA  
PART NO.: --  
Revision --  
Page 2

ADD BAY - DOUBLE SIDED GONDOLA -  
PERFORATED - W/ SKIRT DRAWER - SPECIAL  
W900 x H2115 x D270

PRODUCT CODE: **RFA1523**

Date: 9/07/2024

Drawn by PS

Checked by --

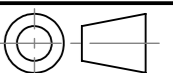

DO NOT SCALE

Scale@A3 1:10

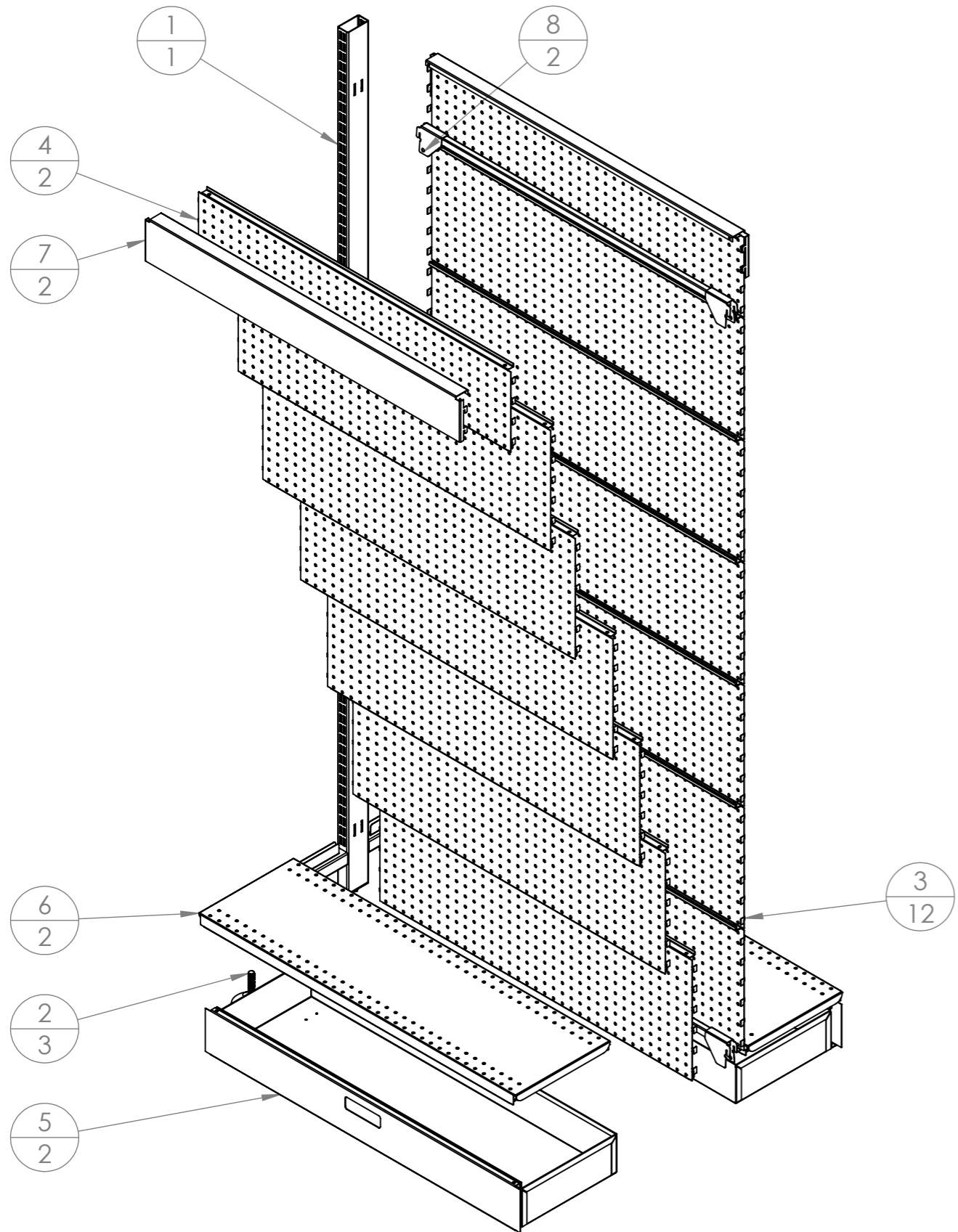

ITEM NO.	PartNo	DESCRIPTION	QTY.
1	RFA1152	2115mm (H) WALL BAY POST	1
2	RFA1153	BOLT DOWN LEVELLER DIA 80-3 HOLE	3
3	RFA1104	CLIP IN PANEL - 900(W) X 300 H) - PERFORATED - MATTE BLACK	12
4	RFA1103	CLIP IN PANEL - W900 X H200 - PERFORATED - MATTE BLACK	2
5	RFA1115	SKIRT DRAWER BOX - 900mm	2
6	RFA0402	SHELF-STEEL-W900xD270	2
7	RFA1124	SNAP IN TOP CAP_BLACK	2
8	RFA1138	POST - SPACER BRACKET	2

**AP ASSOCIATED PROJECTS** COMMERCIAL BUILDERS, PROJECT MANAGERS, PLANNERS & DESIGNERS  
 T 03 8787 3000 F 03 8787 3025  
 48-58 Cyber Loop, Dandenong South VIC 3175

Rev	Date	Description

ALL DIMENSIONS IN (mm)  
 UNLESS OTHERWISE SPECIFIED  
 BREAK ALL SHARP EDGES

TOLERANCES  
 (BEFORE PAINTING  
 & AFTER PLATING)  
 X ± 1.00  
 X.X ± 0.50  
 X.XX ± 0.10  
 ANGLES ± 0.5°

**A03- EXPLODED**  
 CLIENT: RFA  
 PROJ. NO.: TBA  
 PART NO.: --  
 Revision --  
 Page 3

ADD BAY - DOUBLE SIDED GONDOLA - PERFORATED - W/ SKIRT DRAWER - SPECIAL  
 W900 x H2115 x D270

PRODUCT CODE: **RFA1523**

Date: 9/07/2024  
 Drawn by PS  
 Checked by --

DO NOT SCALE  
 Scale@A3 1:10