

FINISH: P/C PEARL WHITE

AP ASSOCIATED PROJECTS COMMERCIAL BUILDERS,
PROJECT MANAGERS,
PLANNERS & DESIGNERS

T 03 8787 3000 F 03 8787 3025
48-58 Cyber Loop, Dandenong South VIC 3175

Rev	Date	Description

ALL DIMENSIONS IN (mm)
UNLESS OTHERWISE SPECIFIED
BREAK ALL SHARP EDGES

TOLERANCES
(BEFORE PAINTING
& AFTER PLATING)
X ± 1.00
X.X ± 0.50
X.XX ± 0.10
ANGLES ± 0.5°

A01- RENDER

CLIENT: RFA

PROJ. NO.: TBA

PART NO.: --

Revision --

Page 1

ADD BAY - DOUBLE SIDED GONDOLA -
PERFORATED - SPECIAL

W900 x H2115 x D270

PRODUCT CODE: **RFA1521**

Date: 9/07/2024

Drawn by PS

Checked by --

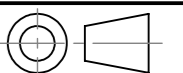

DO NOT SCALE

Scale@A3 1:20

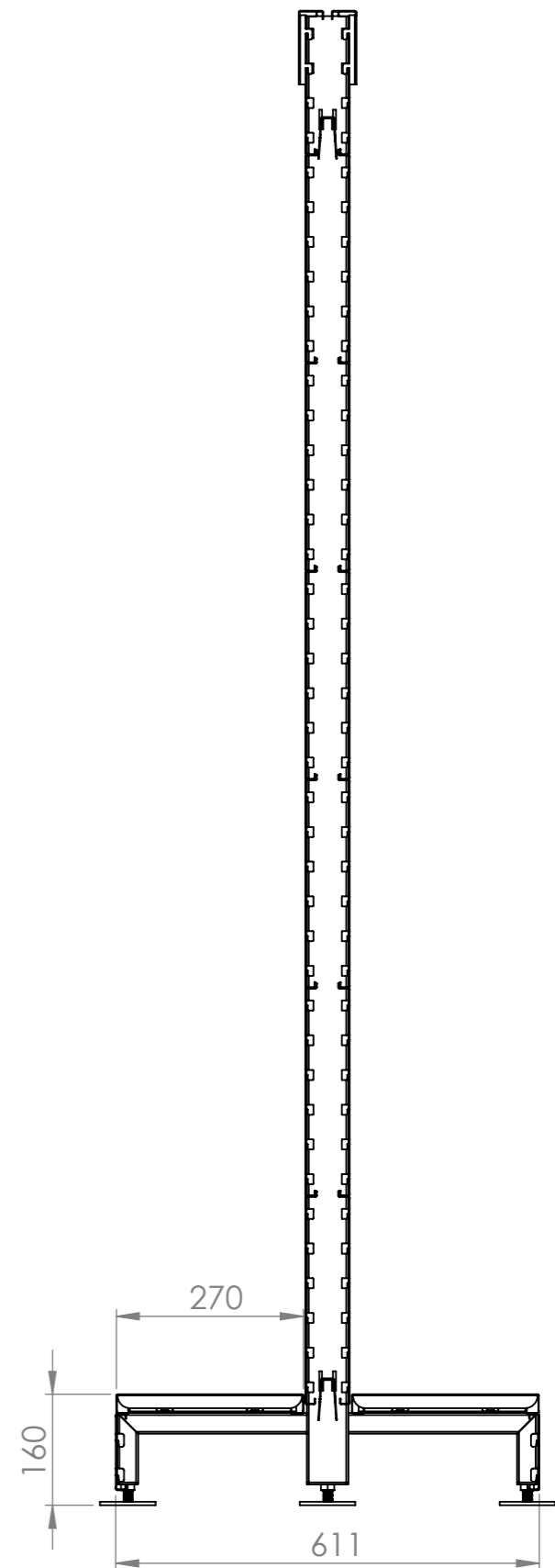
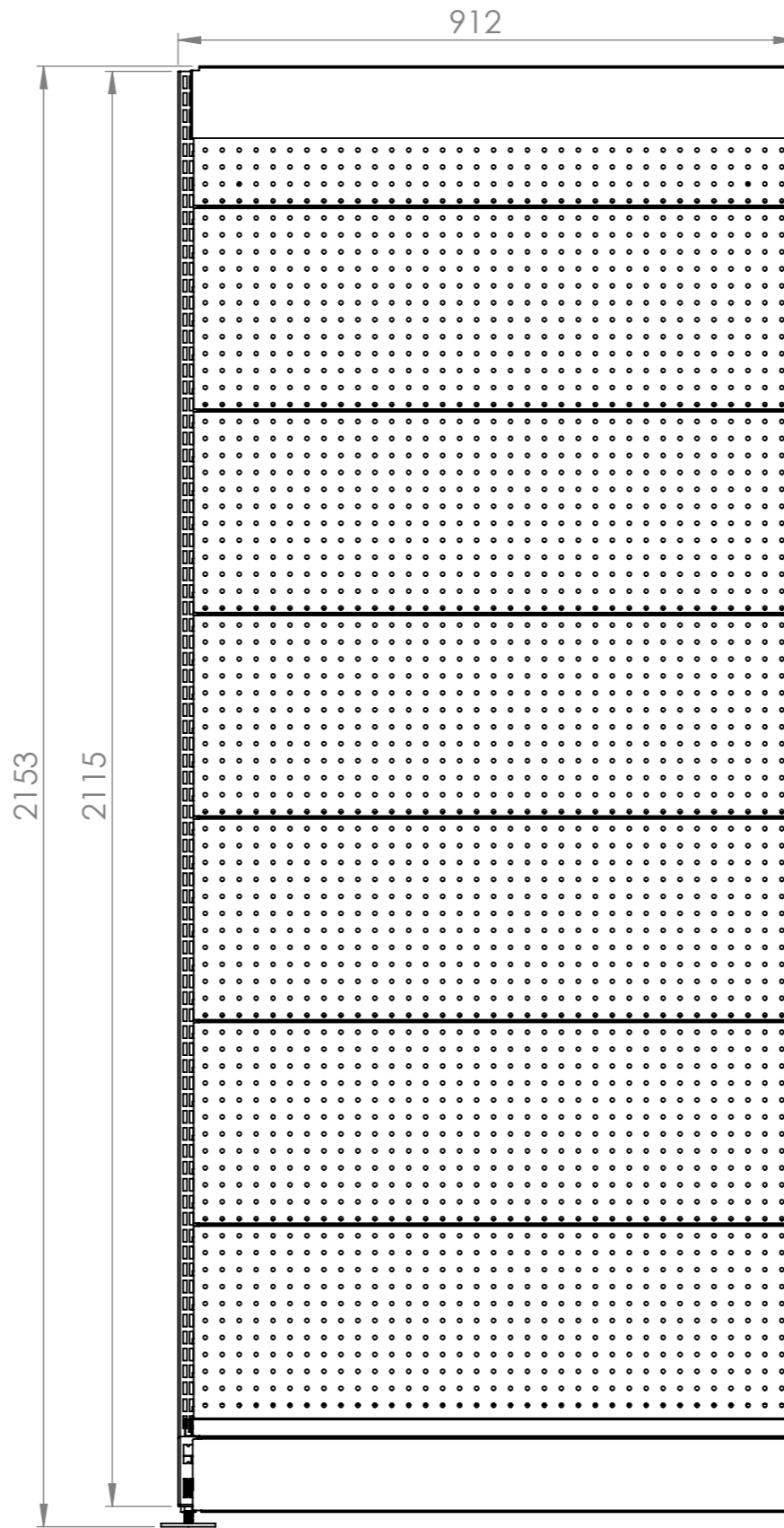
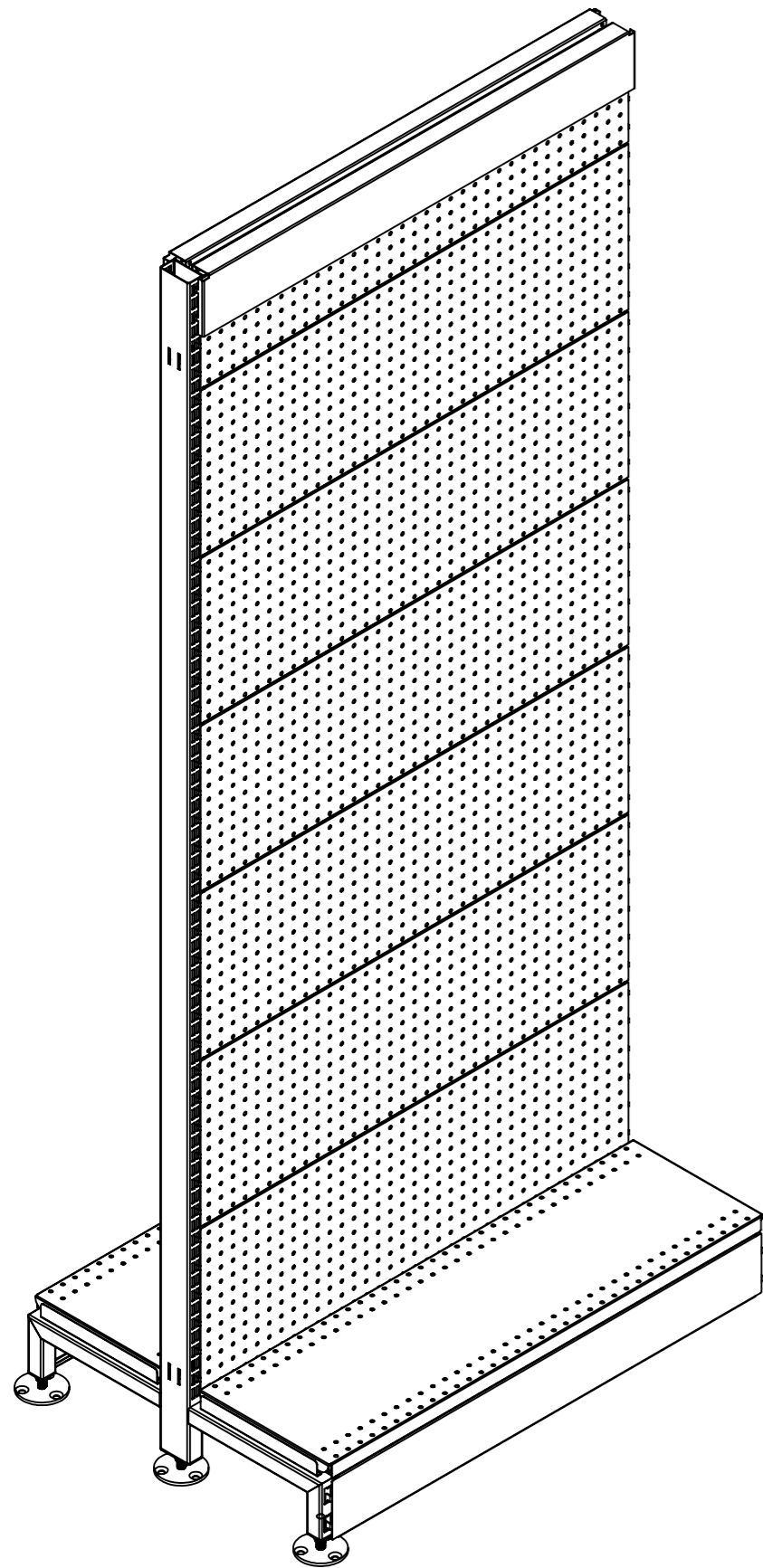

Rev	Date	Description

ALL DIMENSIONS IN (mm)
UNLESS OTHERWISE SPECIFIED
BREAK ALL SHARP EDGES

TOLERANCES
(BEFORE PAINTING
& AFTER PLATING)
X ± 1.00
X.X ± 0.50
X.XX ± 0.10
ANGLES ± 0.5°

A02- DIMENSIONS
CLIENT: RFA
PROJ. NO.: TBA
PART NO.: --
Revision --
Page 2

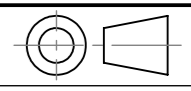
ADD BAY - DOUBLE SIDED GONDOLA - PERFORATED - SPECIAL		
W900 x H2115 x D270		
PRODUCT CODE: RFA1521		DO NOT SCALE
Date:	9/07/2024	
Drawn by	PS	
Checked by	--	Scale@A3 1:10

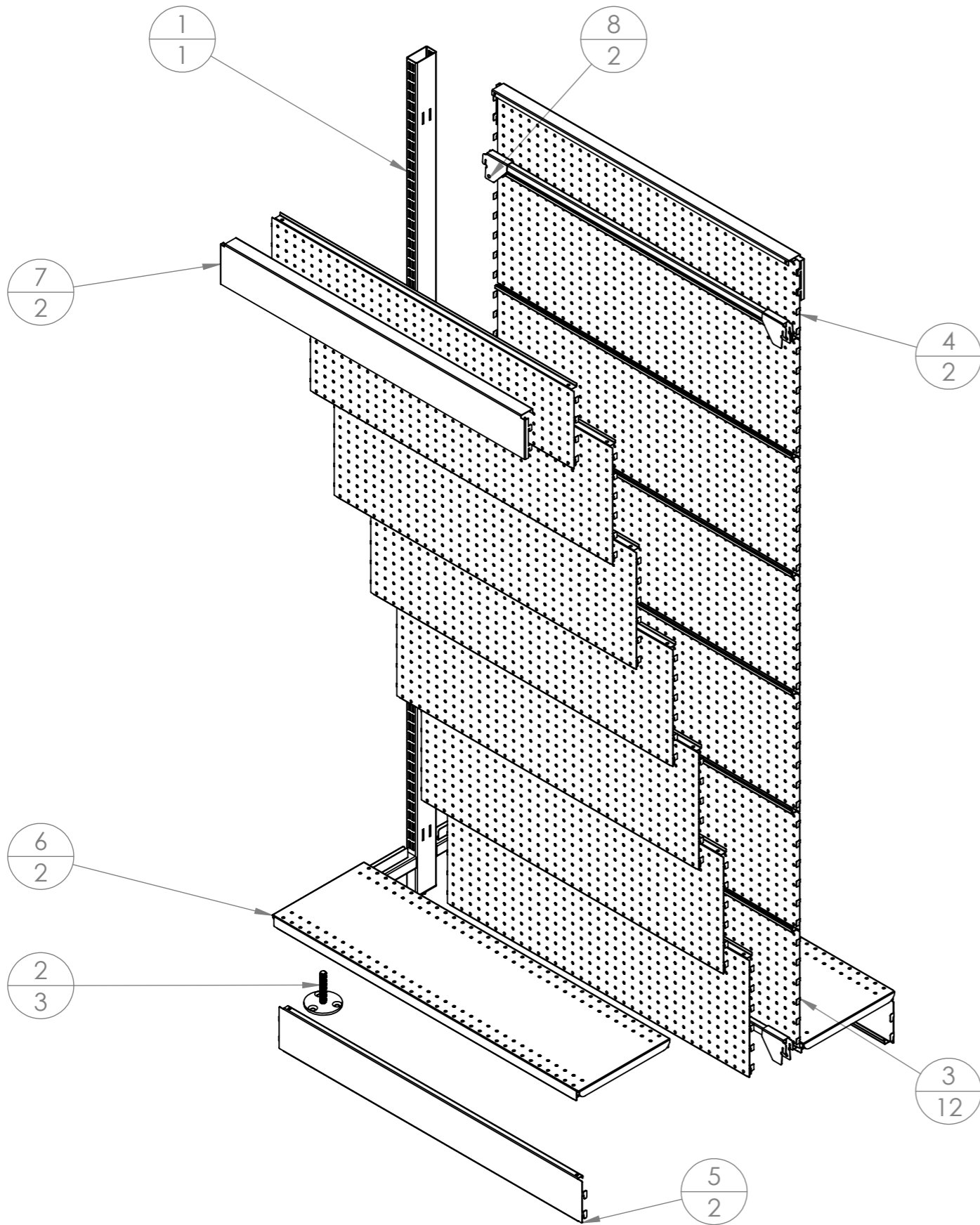

ITEM NO.	PartNo	DESCRIPTION	QTY.
1	RFA1152	2115mm (H) WALL BAY POST	1
2	RFA1153	BOLT DOWN LEVELLER DIA 80-3 HOLE	3
3	RFA1104	CLIP IN PANEL - 900(W) X 300 (H) - PERFORATED - MATTE BLACK	12
4	RFA1103	CLIP IN PANEL - W900 X H200 - PERFORATED - MATTE BLACK	2
5	RFA1110	900 BOTTOM SKIRT	2
6	RFA0402	SHELF-STEEL-W900xD270	2
7	RFA1124	SNAP IN TOP CAP_BLACK	2
8	RFA1138	POST - SPACER BRACKET	2

Rev	Date	Description

ALL DIMENSIONS IN (mm)
 UNLESS OTHERWISE SPECIFIED
 BREAK ALL SHARP EDGES

TOLERANCES
 (BEFORE PAINTING
 & AFTER PLATING)
 X ± 1.00
 X.X ± 0.50
 X.XX ± 0.10
 ANGLES ± 0.5°

A03- EXPLODED
 CLIENT: RFA
 PROJ. NO.: TBA
 PART NO.: --
 Revision --
 Page 3

ADD BAY - DOUBLE SIDED GONDOLA - PERFORATED - SPECIAL
 W900 x H2115 x D270

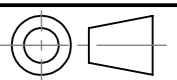
PRODUCT CODE: RFA1521		 DO NOT SCALE
Date:	9/07/2024	
Drawn by	PS	Scale@A3 1:10
Checked by	--	