

FINISH: P/C PEARL WHITE

AP ASSOCIATED PROJECTS COMMERCIAL BUILDERS,
PROJECT MANAGERS,
PLANNERS & DESIGNERS

T 03 8787 3000 F 03 8787 3025
48-58 Cyber Loop, Dandenong South VIC 3175

Rev	Date	Description

ALL DIMENSIONS IN (mm)
UNLESS OTHERWISE SPECIFIED
BREAK ALL SHARP EDGES

TOLERANCES
(BEFORE PAINTING
& AFTER PLATING)
X ± 1.00
X.X ± 0.50
X.XX ± 0.10
ANGLES ± 0.5°

A01- RENDER

CLIENT: RFA

PROJ. NO.: TBA

PART NO.: --

Revision --

Page 1

START BAY - DOUBLE SIDED GONDOLA - NON PERF
W./ SKIRT DRAWER
W600 x H1815 x D270

PRODUCT CODE: **RFA1510**

Date: 8/07/2024

Drawn by PS

Checked by --

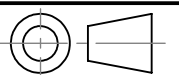

DO NOT SCALE

Scale@A3 1:20

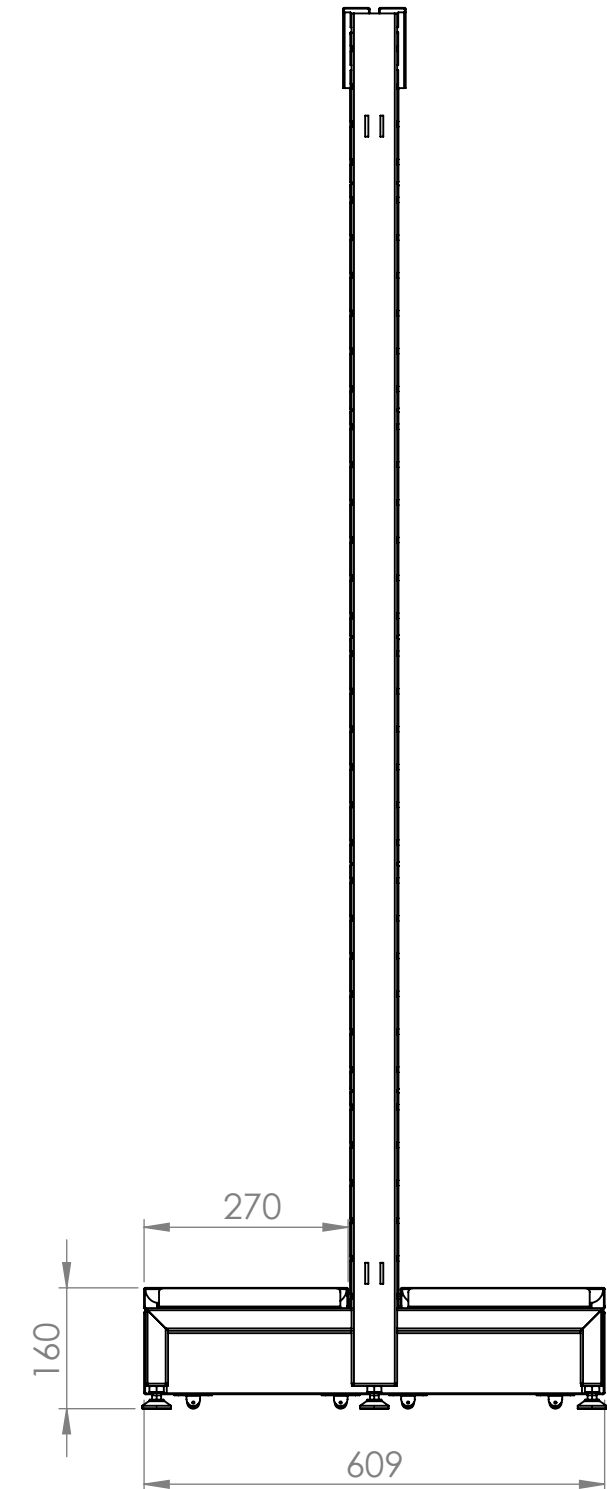
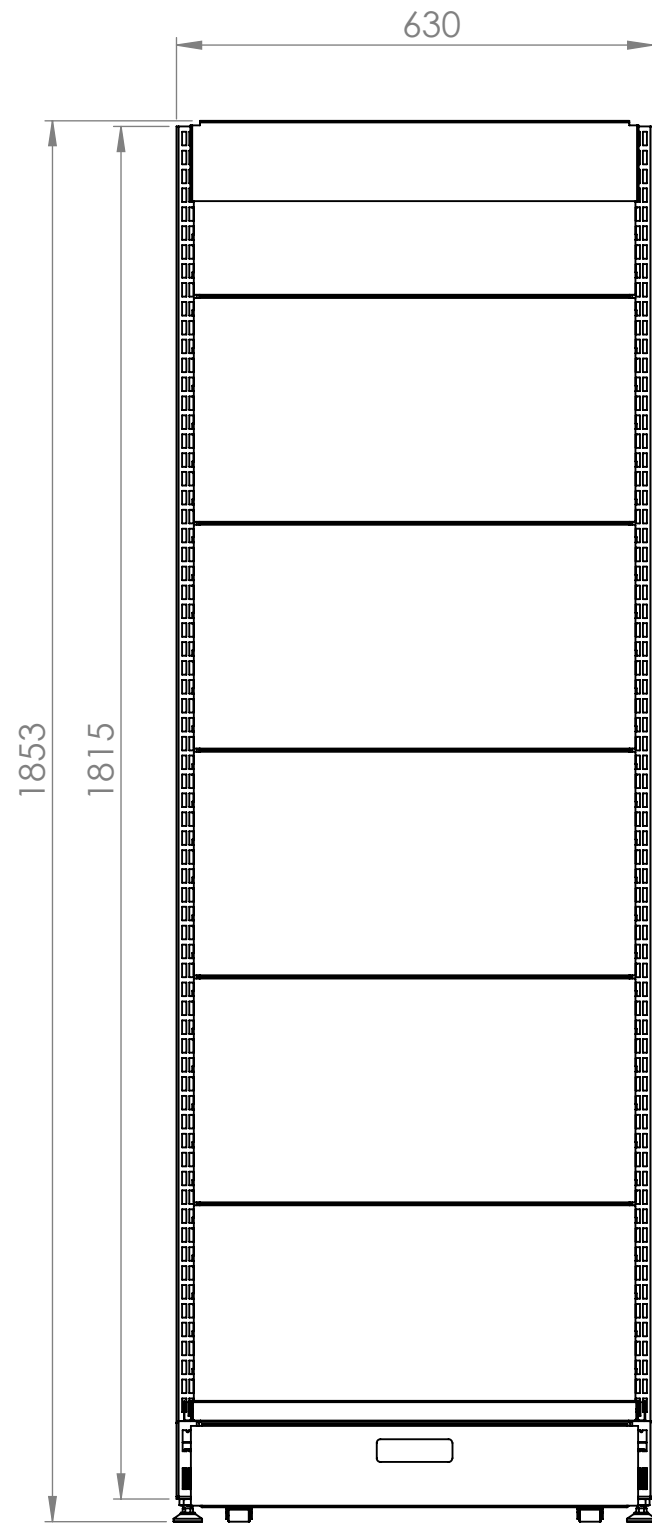
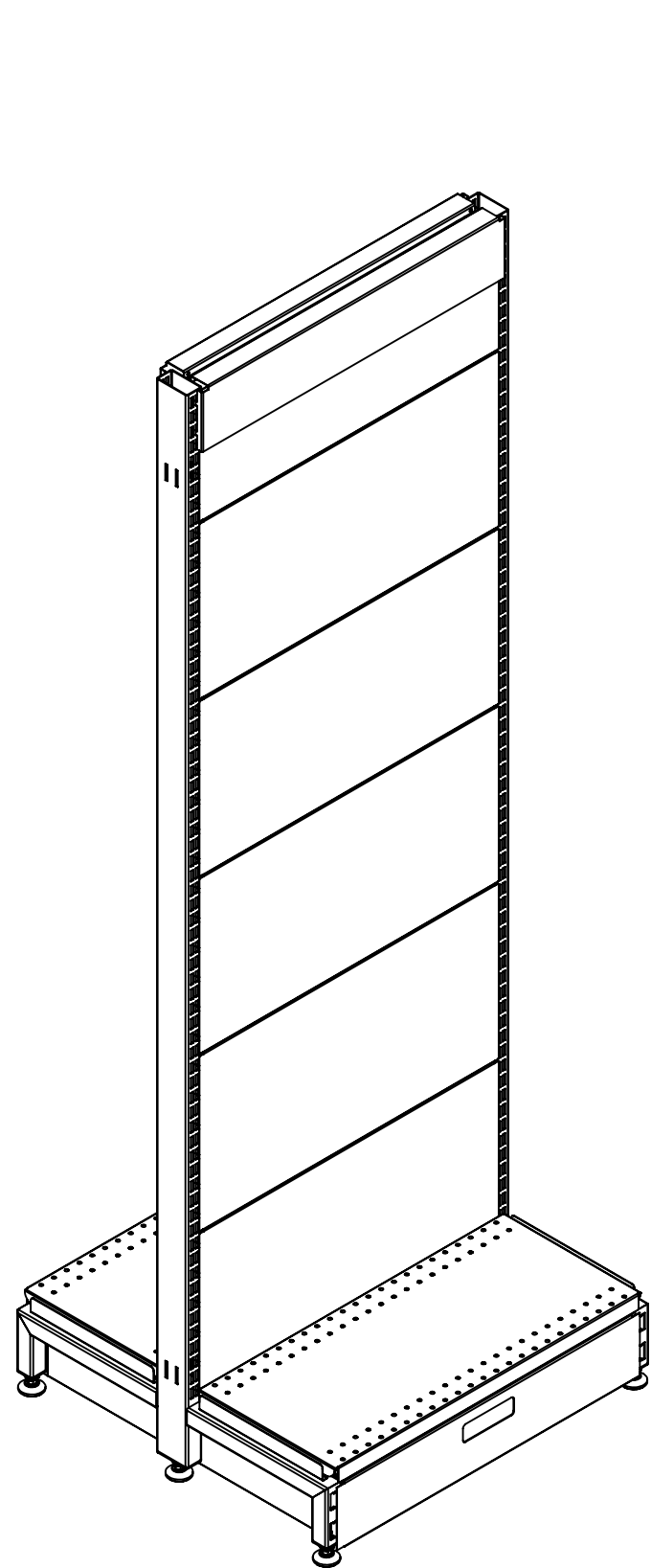

Rev	Date	Description

ALL DIMENSIONS IN (mm)
UNLESS OTHERWISE SPECIFIED
BREAK ALL SHARP EDGES

TOLERANCES
(BEFORE PAINTING
& AFTER PLATING)
X ± 1.00
X.X ± 0.50
X.XX ± 0.10
ANGLES ± 0.5°

A02- DIMENSIONS

CLIENT: RFA
PROJ. NO.: TBA
PART NO.: --
Revision --
Page 2

START BAY - DOUBLE SIDED GONDOLA - NON PERF
W./ SKIRT DRAWER
W600 x H1815 x D270

PRODUCT CODE: **RFA1510**

Date: 8/07/2024

Drawn by PS

Checked by --

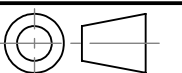

DO NOT SCALE

Scale@A3 1:10

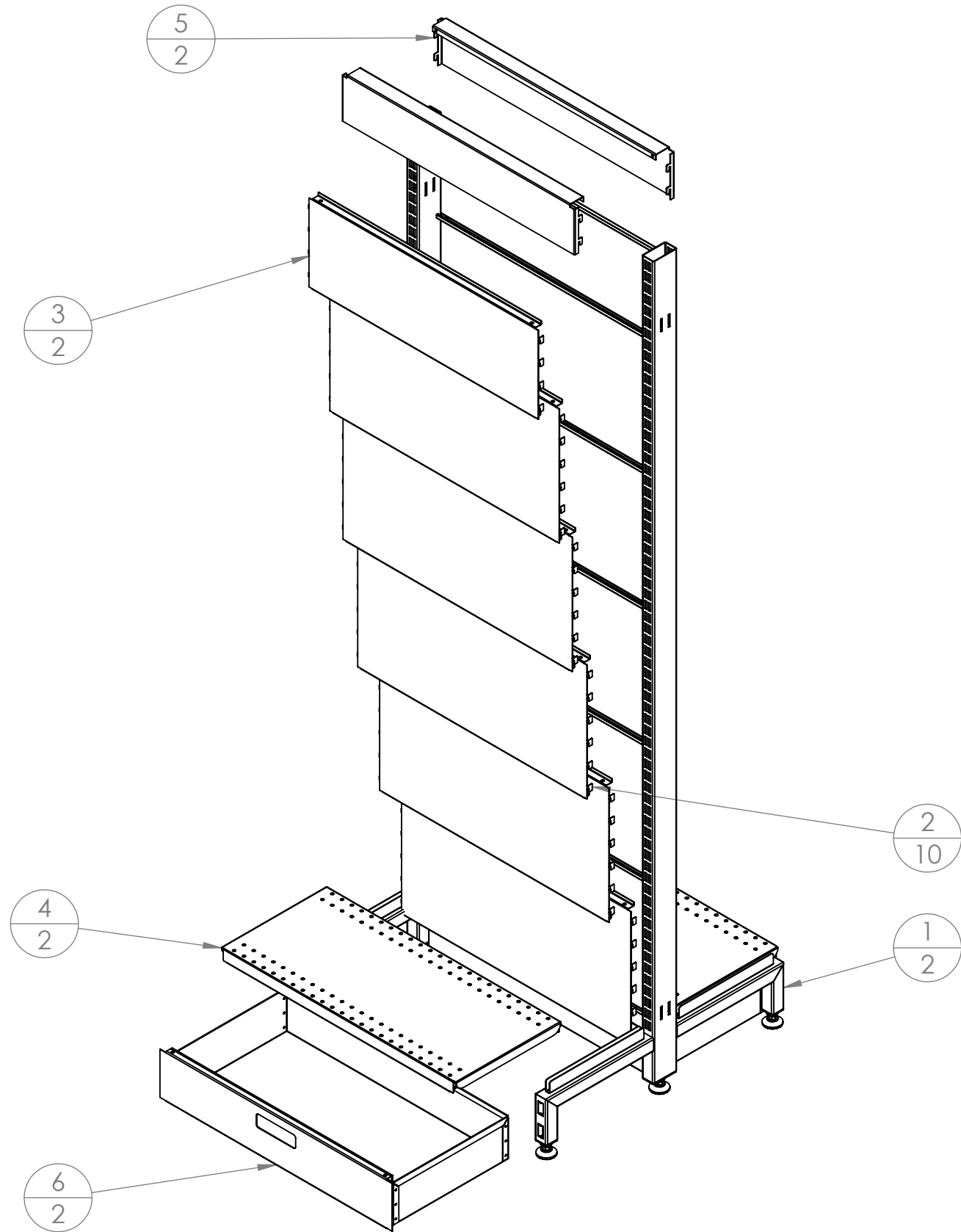

ITEM NO.	PartNo	DESCRIPTION	QTY.
1	RFA1150	1815mm (H) WALL BAY POST	2
2	RFA1106	CLIP IN PANEL - 600(W) X 300(H) - NON PERFORATED - PEARL WHITE	10
3	RFA1105	CLIP IN PANEL - 600(W) X 200(H) - NON PERFORATED - PEARL WHITE	2
4	RFA0400	600mm(W)x270mm(D) STEEL SHELF	2
5	RFA1123	SNAP IN TOP CAP	2
6	RFA1114	SKIRT DRAWER BOX	2

Rev	Date	Description

ALL DIMENSIONS IN (mm)
UNLESS OTHERWISE SPECIFIED
BREAK ALL SHARP EDGES

TOLERANCES
(BEFORE PAINTING
& AFTER PLATING)
X ± 1.00
X.X ± 0.50
X.XX ± 0.10
ANGLES ± 0.5°

A03- EXPLODED

CLIENT: RFA
PROJ. NO.: TBA
PART NO.: --
Revision --
Page 3

**START BAY - DOUBLE SIDED GONDOLA - NON PERF
W./ SKIRT DRAWER**
W600 x H1815 x D270

PRODUCT CODE: **RFA1510**

Date: 8/07/2024

Drawn by PS

Checked by --

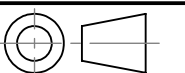

DO NOT SCALE

Scale@A3 1:10