

FINISH: P/C PEARL WHITE

AP ASSOCIATED PROJECTS COMMERCIAL BUILDERS,
PROJECT MANAGERS,
PLANNERS & DESIGNERS

T 03 8787 3000 F 03 8787 3025
48-58 Cyber Loop, Dandenong South VIC 3175

Rev	Date	Description

ALL DIMENSIONS IN (mm)
UNLESS OTHERWISE SPECIFIED
BREAK ALL SHARP EDGES

TOLERANCES
(BEFORE PAINTING
& AFTER PLATING)
X ± 1.00
X.X ± 0.50
X.XX ± 0.10
ANGLES ± 0.5°

A01- RENDER

CLIENT: RFA

PROJ. NO.: TBA

PART NO.: --

Revision --

Page 1

START BAY - DOUBLE SIDED GONDOLA - DRAWER
W900 x H1815 x D270

PRODUCT CODE: **RFA1506**

Date: 5/07/2024

Drawn by PS

Checked by --

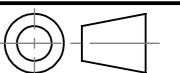

DO NOT SCALE

Scale@A3 1:20

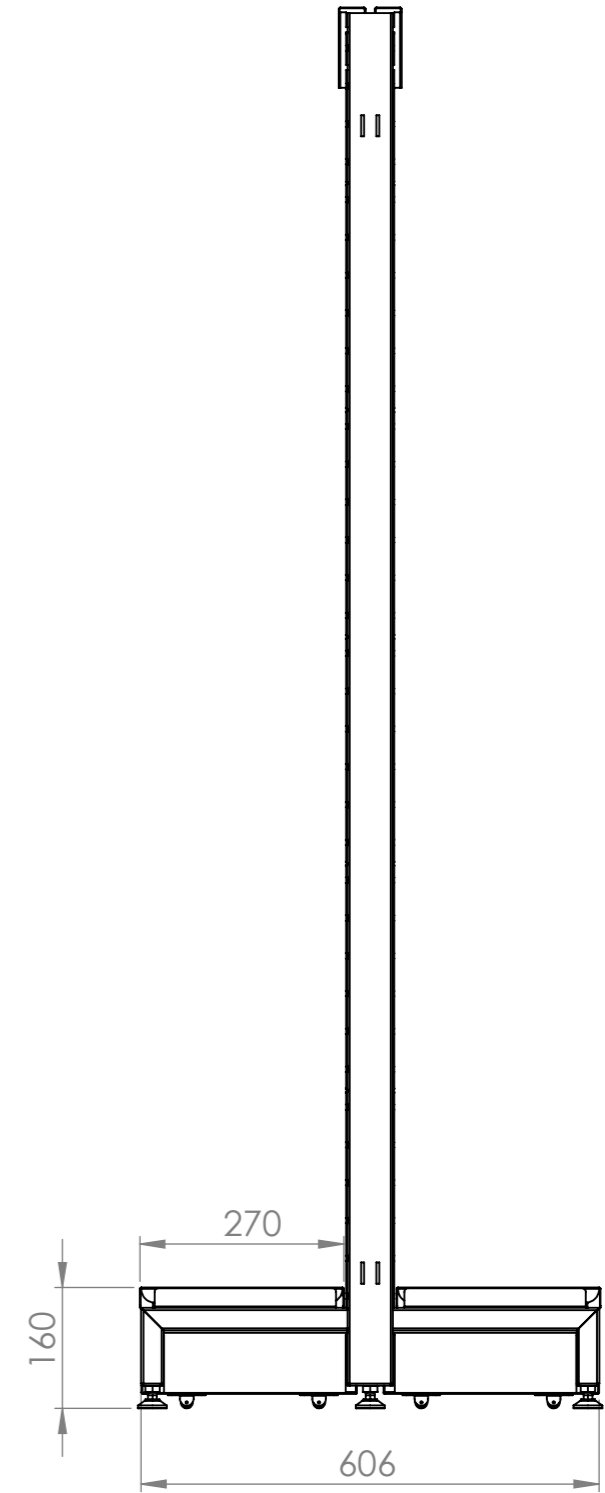
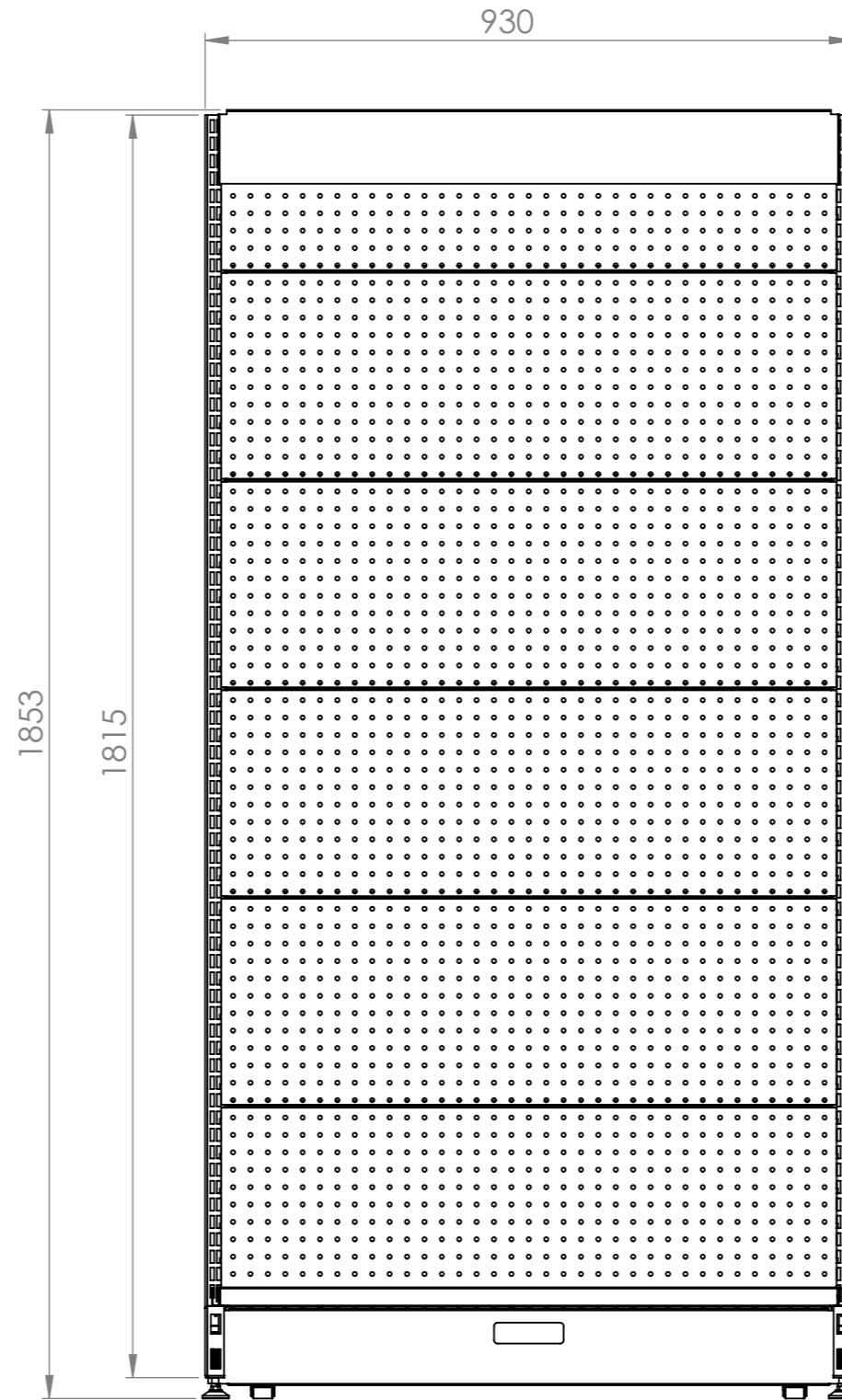
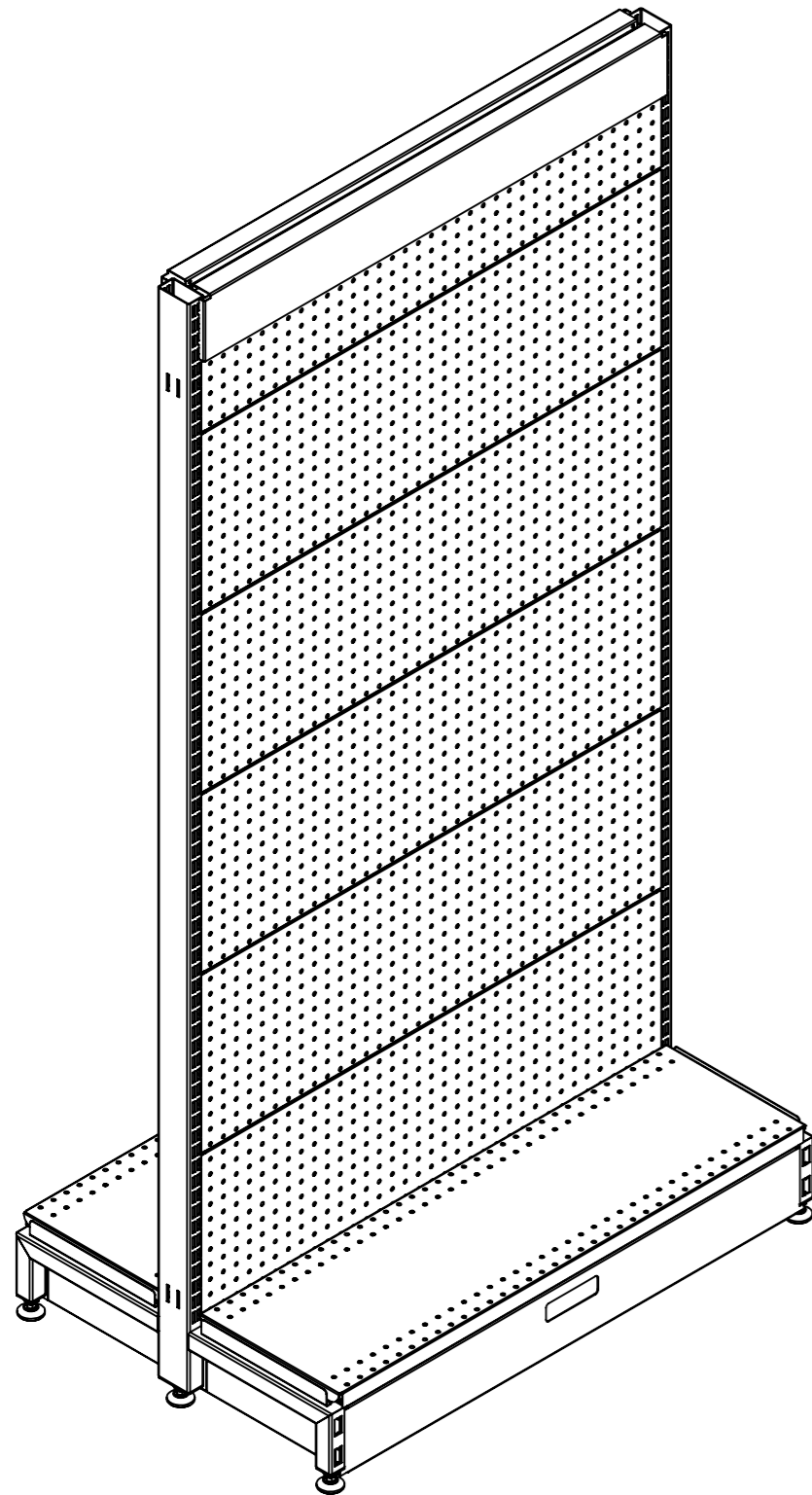

Rev	Date	Description

ALL DIMENSIONS IN (mm)
UNLESS OTHERWISE SPECIFIED
BREAK ALL SHARP EDGES

TOLERANCES
(BEFORE PAINTING
& AFTER PLATING)
X ± 1.00
X.X ± 0.50
X.XX ± 0.10
ANGLES ± 0.5°

A02- DIMENSIONS

CLIENT: RFA
PROJ. NO.: TBA
PART NO.: --
Revision --
Page 2

START BAY - DOUBLE SIDED GONDOLA - DRAWER
W900 x H1815 x D270

PRODUCT CODE: **RFA1506**

Date: 5/07/2024

Drawn by PS

Checked by --

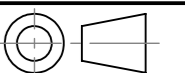

DO NOT SCALE

Scale@A3 1:10

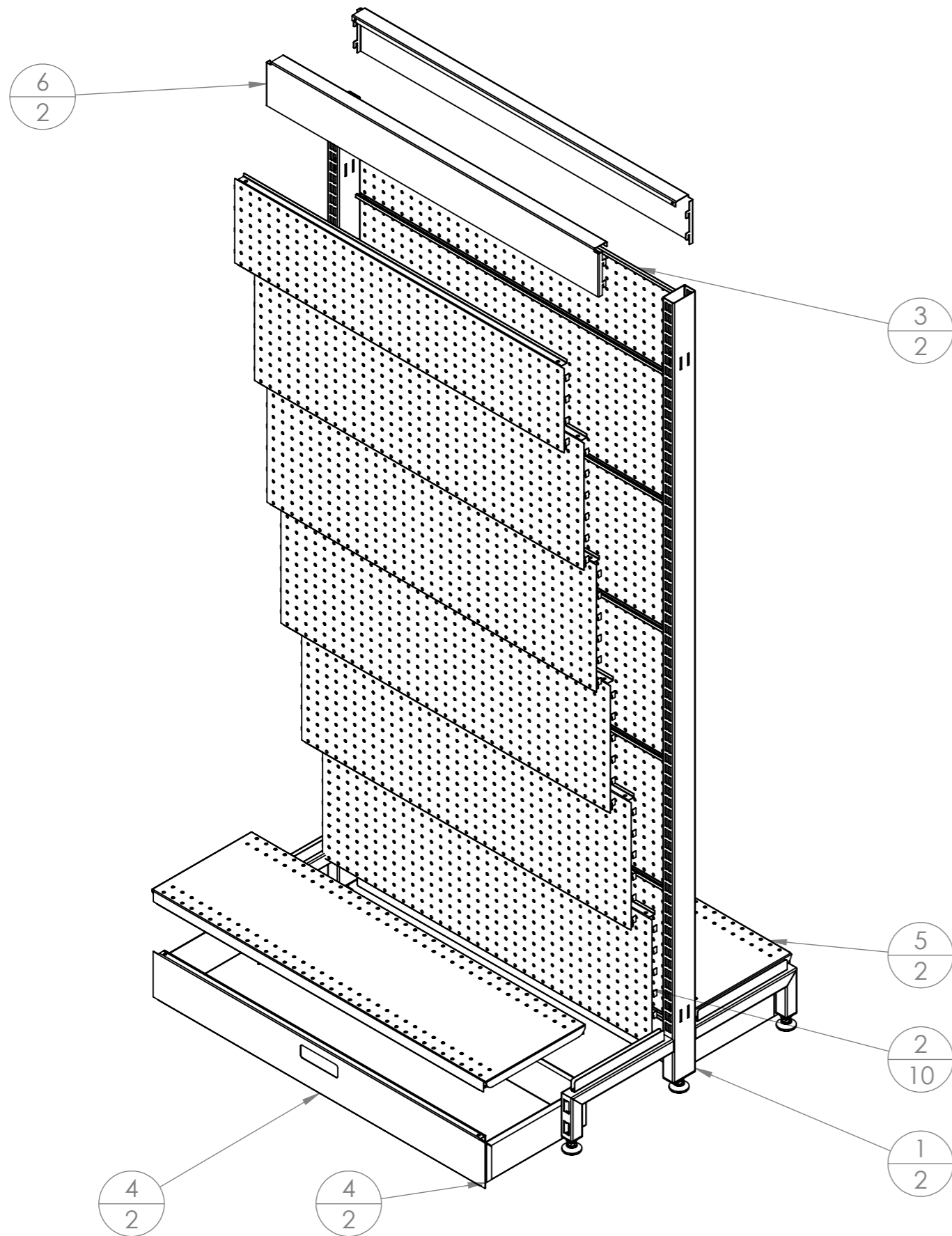

ITEM NO.	PartNo	DESCRIPTION	QTY.
1	RFA1150	1815mm (H) WALL BAY POST	2
2	RFA1104	CLIP IN PANEL - 900(W) X 300 H) - PERFORATED - MATTE BLACK	10
3	RFA1103	CLIP IN PANEL - W900 X H200 - PERFORATED - MATTE BLACK	2
4	RFA1115	SKIRT DRAWER BOX - 900mm	2
5	RFA0402	SHELF-STEEL-W900xD270	2
6	RFA1124	SNAP IN TOP CAP_BLACK	2

Rev	Date	Description

ALL DIMENSIONS IN (mm)
 UNLESS OTHERWISE SPECIFIED
 BREAK ALL SHARP EDGES

TOLERANCES
 (BEFORE PAINTING
 & AFTER PLATING)
 X ± 1.00
 X.X ± 0.50
 X.XX ± 0.10
 ANGLES ± 0.5°

A03- EXPLODED
 CLIENT: RFA
 PROJ. NO.: TBA
 PART NO.: --
 Revision --
 Page 3

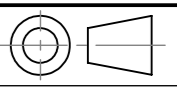
START BAY - DOUBLE SIDED GONDOLA - DRAWER W900 x H1815 x D270		 DO NOT SCALE
PRODUCT CODE: RFA1506	Date: 5/07/2024	
Drawn by PS	Checked by --	Scale@A3 1:10