

FINISH: P/C PEARL WHITE

**AP ASSOCIATED PROJECTS** COMMERCIAL BUILDERS,  
PROJECT MANAGERS,  
PLANNERS & DESIGNERS

T 03 8787 3000 F 03 8787 3025  
48-58 Cyber Loop, Dandenong South VIC 3175

Rev	Date	Description

ALL DIMENSIONS IN (mm)  
UNLESS OTHERWISE SPECIFIED  
BREAK ALL SHARP EDGES

TOLERANCES  
(BEFORE PAINTING  
& AFTER PLATING)  
X ± 1.00  
X.X ± 0.50  
X.XX ± 0.10  
ANGLES ± 0.5°

A01- RENDER

CLIENT: RFA

PROJ. NO.: TBA

PART NO.: --

Revision --

Page 1

ADD BAY - DOUBLE SIDED GONDOLA - PERF.  
W900 x H1815 x D270

PRODUCT CODE: **RFA1505**

Date: 5/07/2024

Drawn by PS

Checked by --

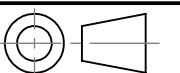

DO NOT SCALE

Scale@A3 1:20

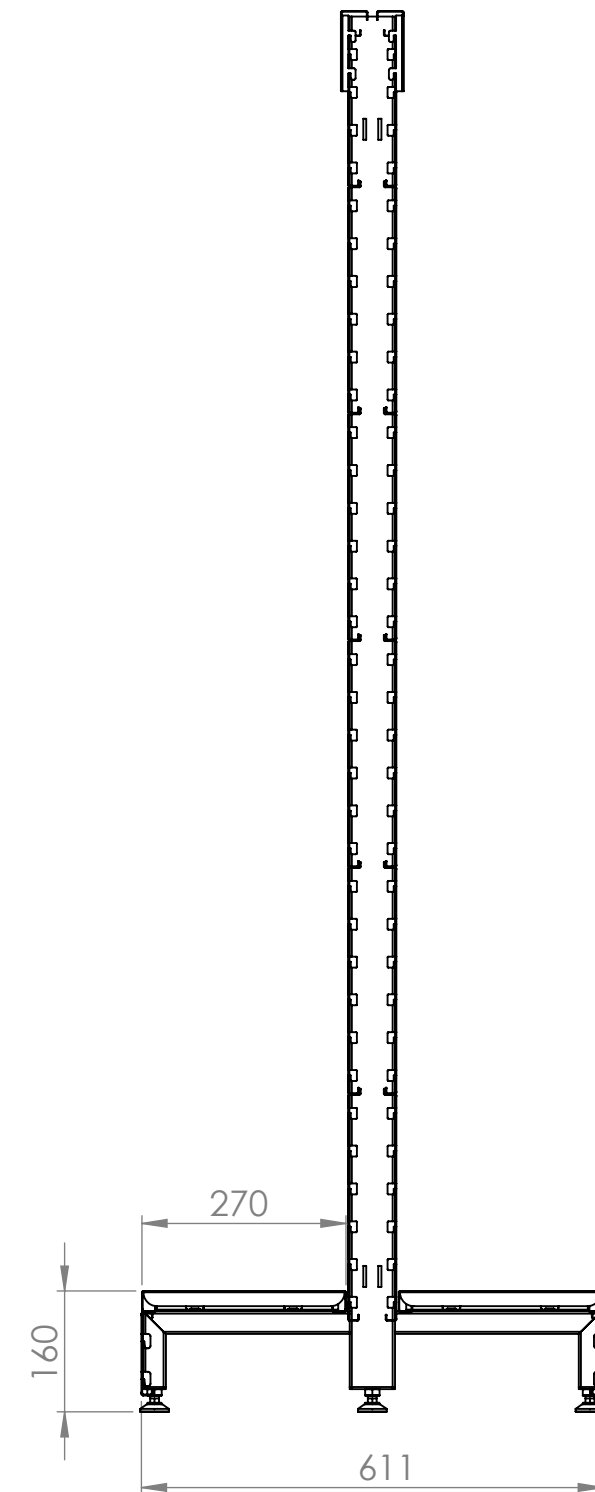
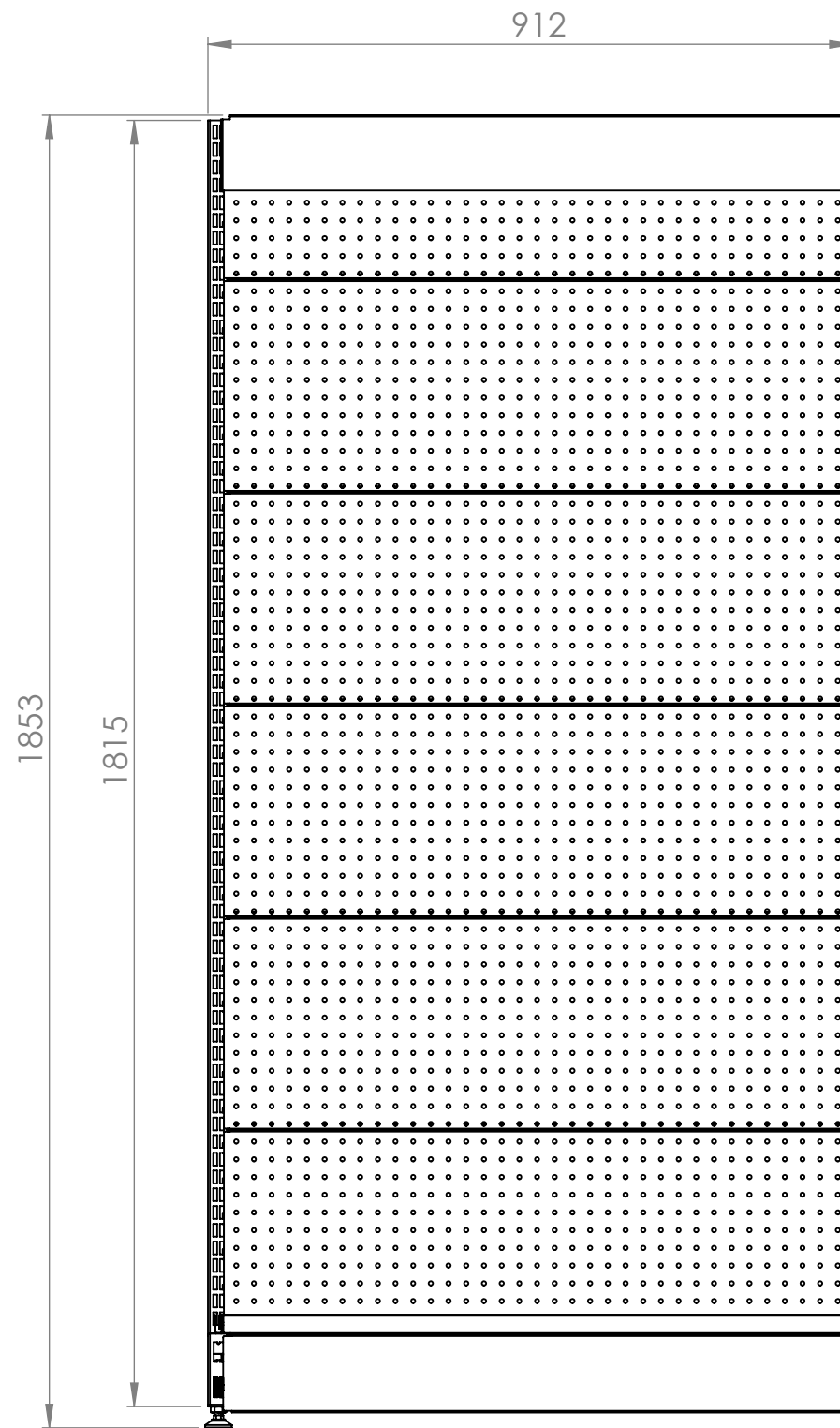
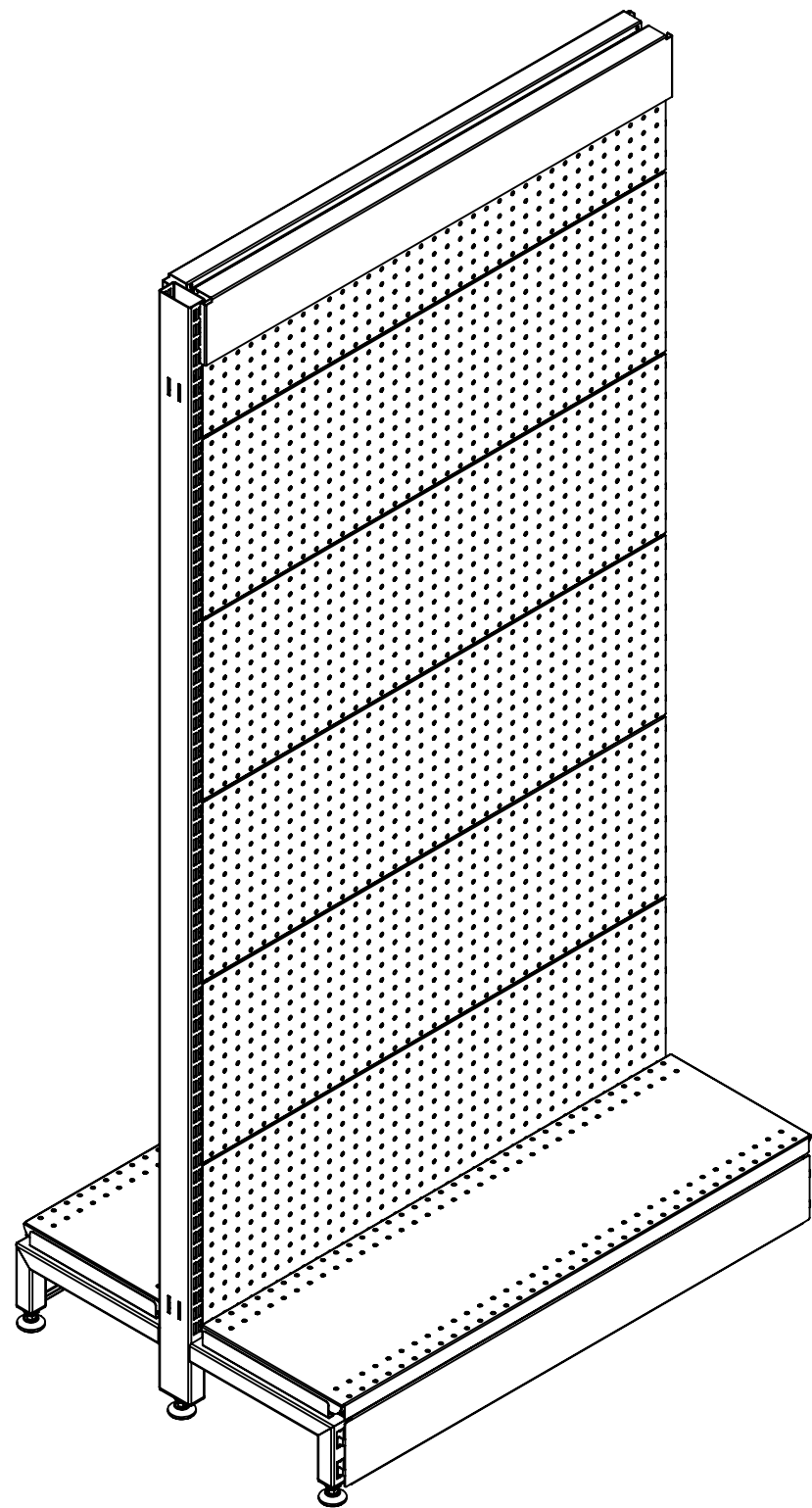

Rev	Date	Description

ALL DIMENSIONS IN (mm)  
UNLESS OTHERWISE SPECIFIED  
BREAK ALL SHARP EDGES

TOLERANCES  
(BEFORE PAINTING  
& AFTER PLATING)  
X ± 1.00  
X.X ± 0.50  
X.XX ± 0.10  
ANGLES ± 0.5°

**A02- DIMENSIONS**

CLIENT: RFA  
PROJ. NO.: TBA  
PART NO.: --  
Revision --  
Page 2

ADD BAY - DOUBLE SIDED GONDOLA - PERF.  
W900 x H1815 x D270

PRODUCT CODE: **RFA1505**

Date: 5/07/2024

Drawn by PS

Checked by --

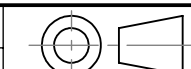

DO NOT SCALE

Scale@A3 1:10

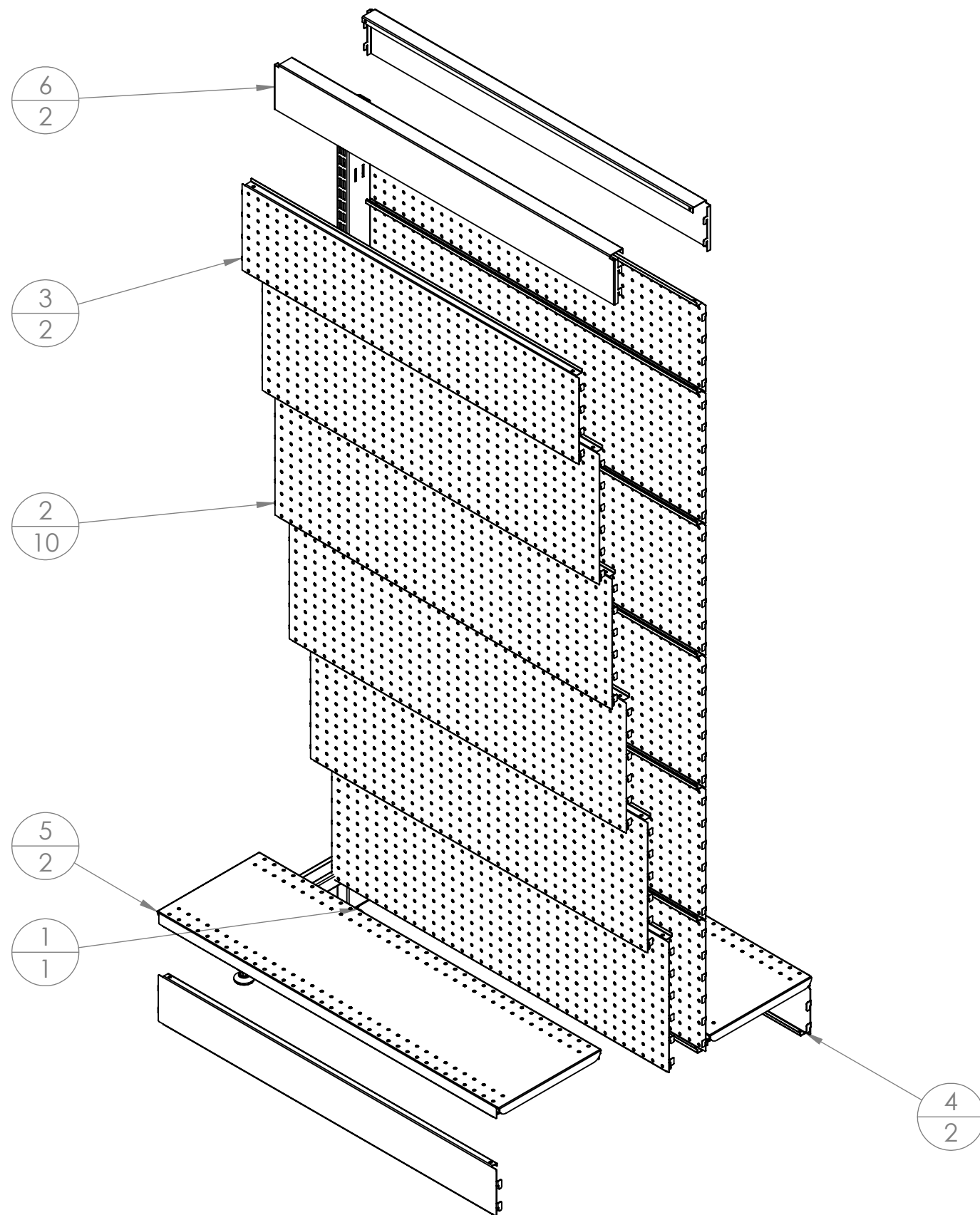

ITEM NO.	PartNo	DESCRIPTION	QTY.
1	RFA1150	1815mm (H) WALL BAY POST	1
2	RFA1104	CLIP IN PANEL - 900(W) X 300 H) - PERFORATED - MATTE BLACK	10
3	RFA1103	CLIP IN PANEL - W900 X H200 - PERFORATED - MATTE BLACK	2
4	RFA1110	900 BOTTOM SKIRT	2
5	RFA0402	SHELF-STEEL-W900xD270	2
6	RFA1124	SNAP IN TOP CAP_BLACK	2

Rev	Date	Description

ALL DIMENSIONS IN (mm)  
UNLESS OTHERWISE SPECIFIED  
BREAK ALL SHARP EDGES

TOLERANCES  
(BEFORE PAINTING  
& AFTER PLATING)  
X ± 1.00  
X.X ± 0.50  
X.XX ± 0.10  
ANGLES ± 0.5°

A03- EXPLODED

CLIENT: RFA  
PROJ. NO.: TBA  
PART NO.: --  
Revision --  
Page 3

ADD BAY - DOUBLE SIDED GONDOLA - PERF.  
W900 x H1815 x D270

PRODUCT CODE: **RFA1505**

Date: 5/07/2024

Drawn by PS

Checked by --

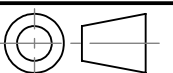

DO NOT SCALE

Scale@A3 1:10