



FINISH: MATTE BLACK

Rev	Date	Description

ALL DIMENSIONS IN (mm)
UNLESS OTHERWISE SPECIFIED
BREAK ALL SHARP EDGES

TOLERANCES
(BEFORE PAINTING
& AFTER PLATING)
X ± 1.00
X.X ± 0.50
X.XX ± 0.10
ANGLES ± 0.5°

A01- RENDER
CLIENT: RFA1328
PROJ. NO.: TBA
PART NO.: --
Revision --
Page 1

200(H) GONDOLA TOPPER SIGNS - W/
MAGNETS (MATTE BLACK)
-

PRODUCT CODE: -

Date: 8/08/2023

Drawn by DH

Checked by --

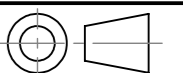

DO NOT SCALE

Scale@A3 1:1

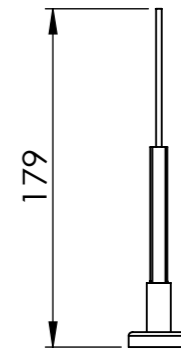
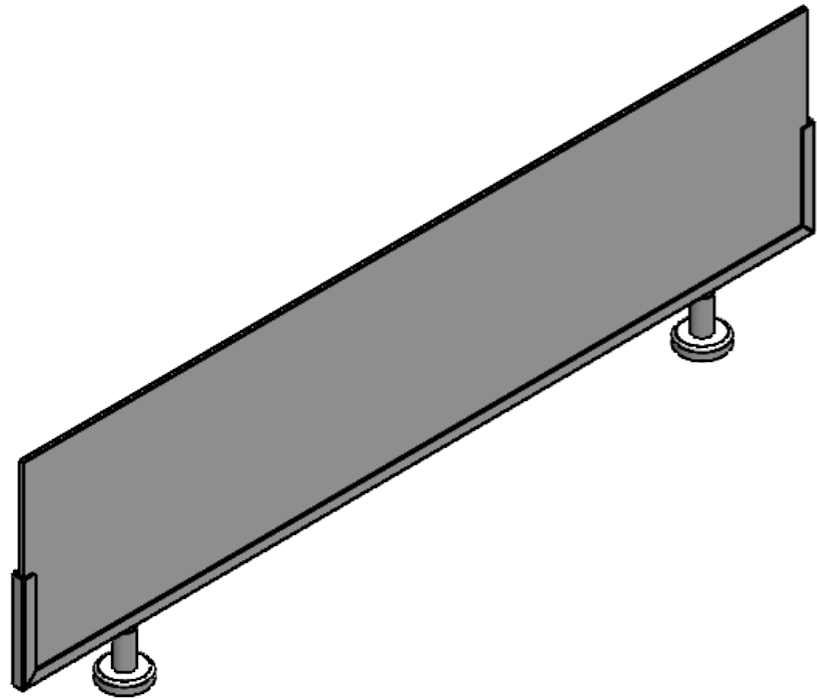

Rev	Date	Description

ALL DIMENSIONS IN (mm)
UNLESS OTHERWISE SPECIFIED
BREAK ALL SHARP EDGES

TOLERANCES
(BEFORE PAINTING
& AFTER PLATING)
X ± 1.00
X.X ± 0.50
X.XX ± 0.10
ANGLES ± 0.5°

A02- RENDER

CLIENT: RFA1328

PROJ. NO.: TBA

PART NO.: --

Revision --

Page 2

200(H) GONDOLA TOPPER SIGNS - W/
MAGNETS (MATTE BLACK)

PRODUCT CODE: -

Date: 8/08/2023

Drawn by DH

Checked by --

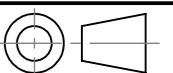

DO NOT SCALE

Scale@A3 1:4

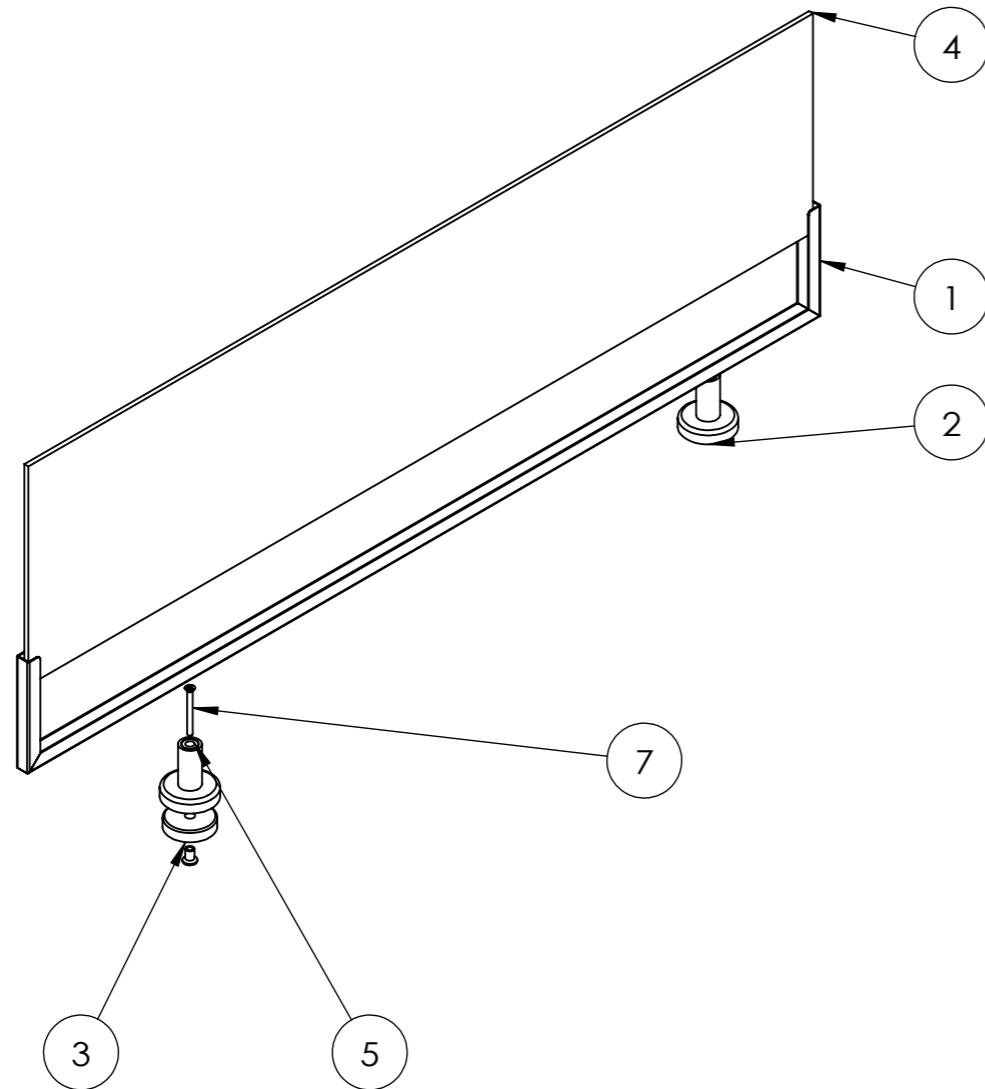

ITEM NO.	PRODUCT CODE	DESCRIPTION	FINISH	QTY.
1	RFA1327	SIGN GONDOLA TOPPER FRAME	PEARL WHITE	1
2	RFA1327	GTS MAGNET HOLDER	PEARL WHITE	2
3	RFA1327	GST HOLED MANGET	PEARL WHITE	2
4	RFA1327	GTS SIGN PANEL - ARTWORK	-	1
5	RFA1327	GTS SLEEVE	PEARL WHITE	2
6	-	BARREL NUT CSK M3	RAW	2
7		M3 X 30 CSK HEX SCREW		2

Rev	Date	Description

ALL DIMENSIONS IN (mm)
 UNLESS OTHERWISE SPECIFIED
 BREAK ALL SHARP EDGES

 TOLERANCES
 (BEFORE PAINTING
 & AFTER PLATING)
 X ± 1.00
 X.X ± 0.50
 X.XX ± 0.10
 ANGLES ± 0.5°

A03- RENDER
 CLIENT: RFA1328
 PROJ. NO.: TBA
 PART NO.: --
 Revision --
 Page 3

**200(H) GONDOLA TOPPER SIGNS - W/.
 MAGNETS (MATTE BLACK)**
 -
 PRODUCT CODE: -
 Date: 8/08/2023
 Drawn by DH
 Checked by --
 DO NOT SCALE
 Scale@A3 1:5