



FINISH: MATTE BLACK

**AP ASSOCIATED PROJECTS** COMMERCIAL BUILDERS,  
PROJECT MANAGERS,  
PLANNERS & DESIGNERS

T 03 8787 3000 F 03 8787 3025  
48-58 Cyber Loop, Dandenong South VIC 3175

Rev	Date	Description

ALL DIMENSIONS IN (mm)  
UNLESS OTHERWISE SPECIFIED  
BREAK ALL SHARP EDGES

TOLERANCES  
(BEFORE PAINTING  
& AFTER PLATING)  
X ± 1.00  
X.X ± 0.50  
X.XX ± 0.10  
ANGLES ± 0.5°

A01- RENDER

CLIENT: -  
PROJ. NO.: TBA  
PART NO.: --  
Revision --  
Page 1

POST WALL BAY 2400mm(H)

-

PRODUCT CODE: **RFA1200**

Date: 27/06/2023

Drawn by DH

Checked by --

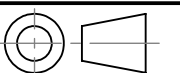

DO NOT SCALE

Scale@A3 1:1

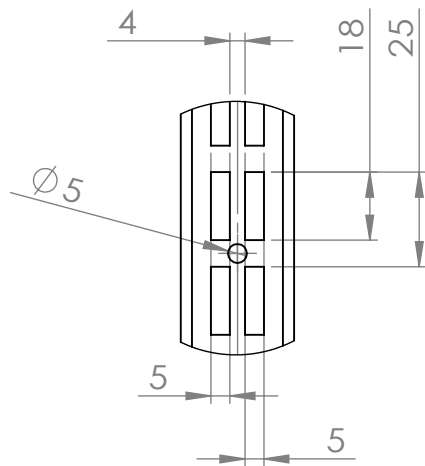

DETAIL C  
SCALE 1 : 2

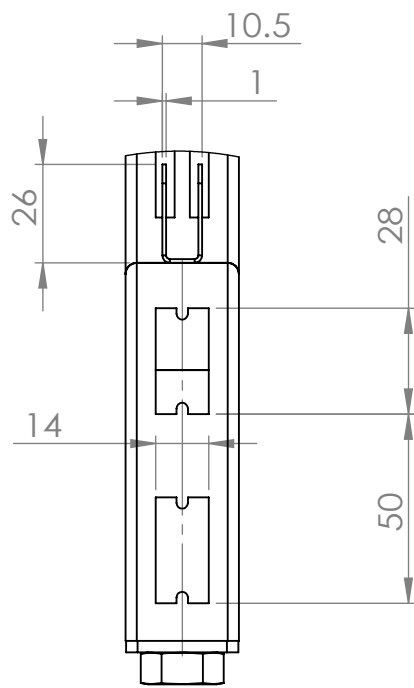

DETAIL A  
SCALE 1 : 2

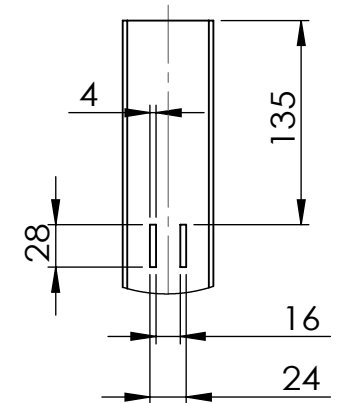
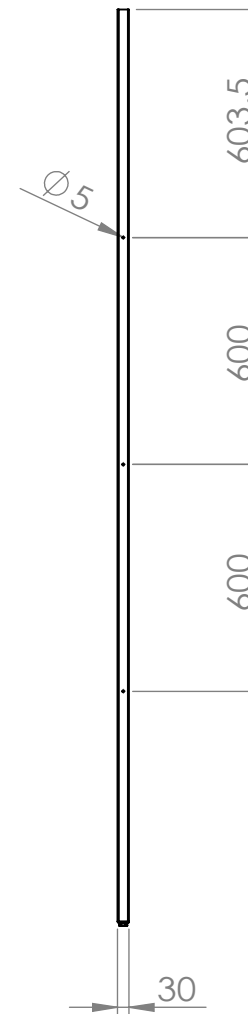
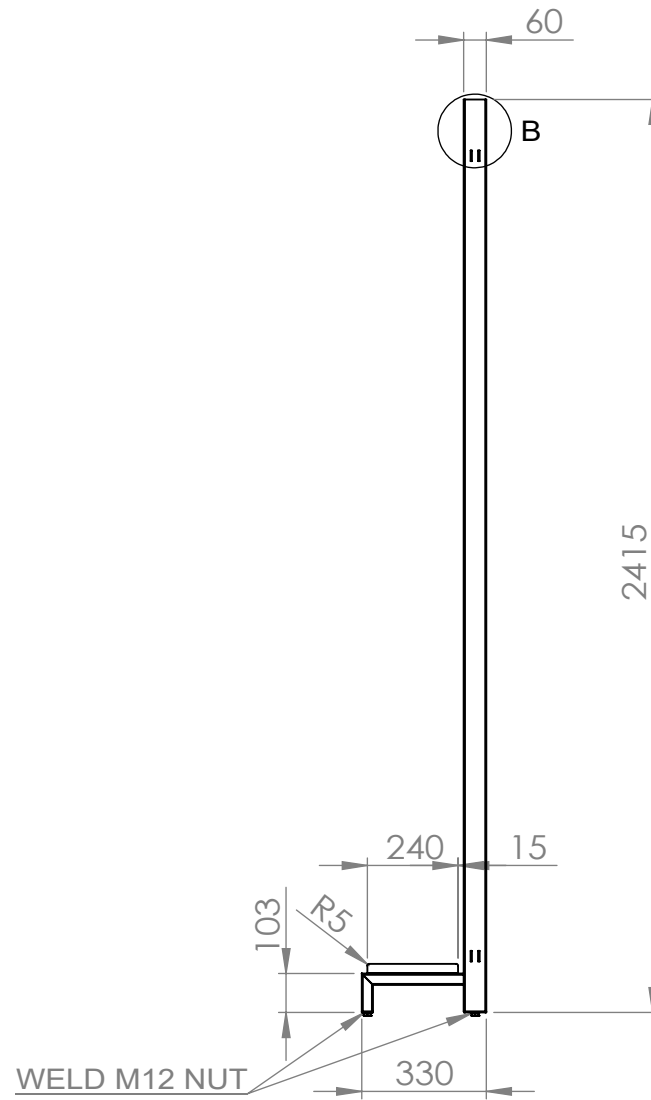
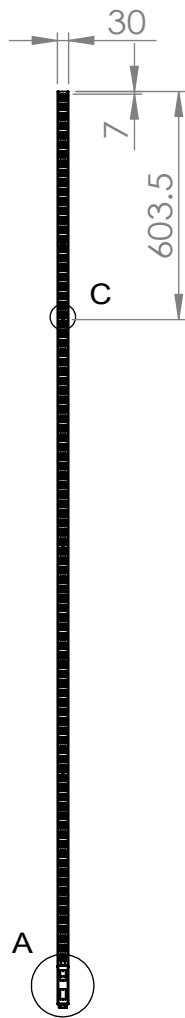

DETAIL B  
SCALE 1 : 5

Rev	Date	Description

ALL DIMENSIONS IN (mm)  
UNLESS OTHERWISE SPECIFIED  
BREAK ALL SHARP EDGES

TOLERANCES  
(BEFORE PAINTING  
& AFTER PLATING)  
X ± 1.00  
X.X ± 0.50  
X.XX ± 0.10  
ANGLES ± 0.5°

A02- CLIENT

CLIENT: -  
PROJ. NO.: TBA  
PART NO.: --  
Revision --  
Page 2

POST WALL BAY 2400mm(H)

-

PRODUCT CODE: **RFA1200**

Date: 27/06/2023

Drawn by DH

Checked by --

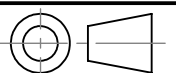

DO NOT SCALE

Scale@A3 1:20