



Rev	Date	Description

ALL DIMENSIONS IN (mm)  
UNLESS OTHERWISE SPECIFIED  
BREAK ALL SHARP EDGES

TOLERANCES  
(BEFORE PAINTING  
& AFTER PLATING)  
X ± 1.00  
X.X ± 0.50  
X.XX ± 0.10  
ANGLES ± 0.5°

A01- RENDER

CLIENT: RFA

PROJ. NO.: TBA

PART NO.: --

Revision --

Page 1

-

600 X 150 TOP CAP -FOR TWCM

PRODUCT CODE: **RFA1134**

Date: 22/06/2023

Drawn by DH

Checked by --

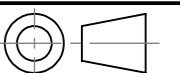

DO NOT SCALE

Scale@A3 1:1

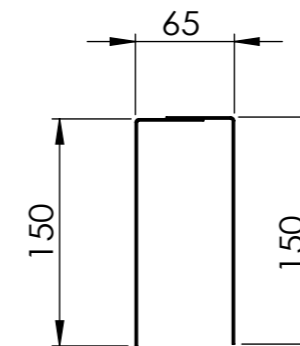
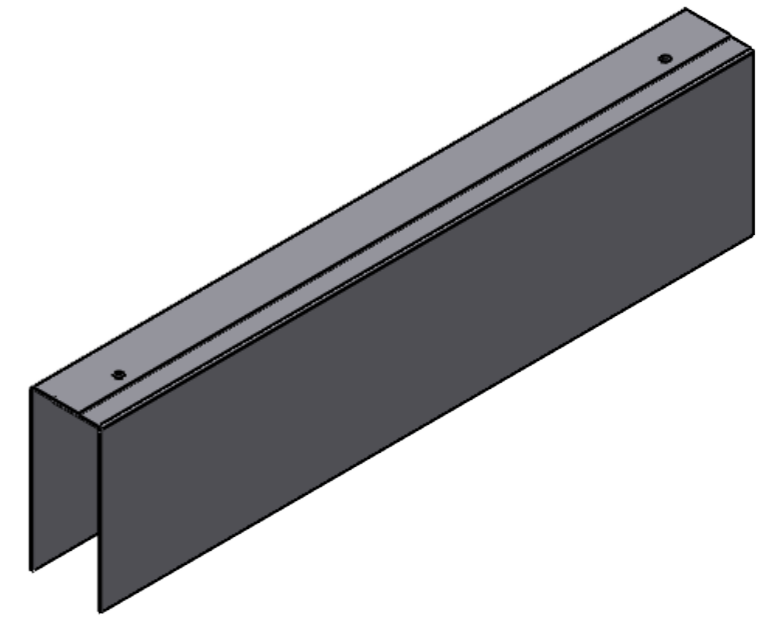
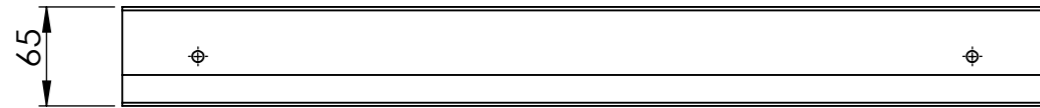

Rev	Date	Description

ALL DIMENSIONS IN (mm)  
UNLESS OTHERWISE SPECIFIED  
BREAK ALL SHARP EDGES

TOLERANCES  
(BEFORE PAINTING  
& AFTER PLATING)  
X ± 1.00  
X.X ± 0.50  
X.XX ± 0.10  
ANGLES ± 0.5°

A02- CLIENT  
CLIENT: RFA  
PROJ. NO.: TBA  
PART NO.: --  
Revision --  
Page 2

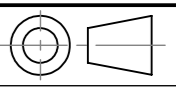
-		600 X 150 TOP CAP -FOR TWCM
PRODUCT CODE: <b>RFA1134</b>		 DO NOT SCALE
Date:	22/06/2023	
Drawn by	DH	
Checked by	--	
		Scale@A3 1:5