

Rev	Date	Description

ALL DIMENSIONS IN (mm)  
UNLESS OTHERWISE SPECIFIED  
BREAK ALL SHARP EDGES

TOLERANCES  
(BEFORE PAINTING  
& AFTER PLATING)  
X ± 1.00  
X.X ± 0.50  
X.XX ± 0.10  
ANGLES ± 0.5°

**A01-RENDER**  
CLIENT: RFA\_1000  
PROJ. NO.: TBA  
PART NO.: --  
Revision --  
Page 1

**RFA1093\_1515mm DENSE END**

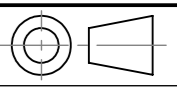
-		
PRODUCT CODE:	<b>RFA1093</b>	
Date:	26/10/2022	DO NOT SCALE
Drawn by	DH	
Checked by	--	
Scale@A3		1:10



Rev	Date	Description

ALL DIMENSIONS IN (mm)  
UNLESS OTHERWISE SPECIFIED  
BREAK ALL SHARP EDGES

TOLERANCES  
(BEFORE PAINTING  
& AFTER PLATING)  
X ± 1.00  
X.X ± 0.50  
X.XX ± 0.10  
ANGLES ± 0.5°

**A02-RENDER**  
CLIENT: RFA\_1000  
PROJ. NO.: TBA  
PART NO.: --  
Revision --  
Page 2

**RFA\_1093\_1515mm DENSE END**

-		
PRODUCT CODE:	<b>-RFA1093</b>	
Date:	26/10/2022	 DO NOT SCALE
Drawn by	DH	
Checked by	--	
		Scale@A3 1:10

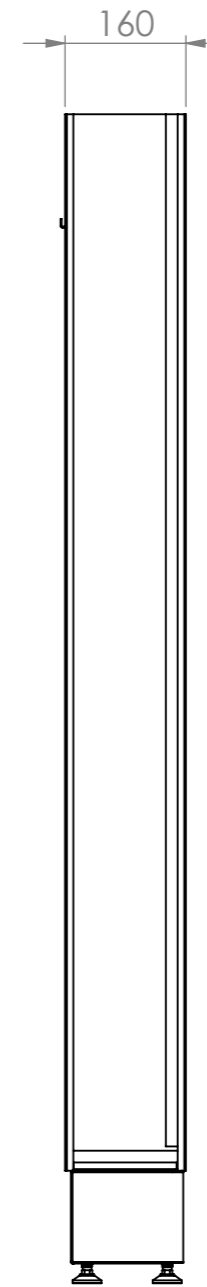
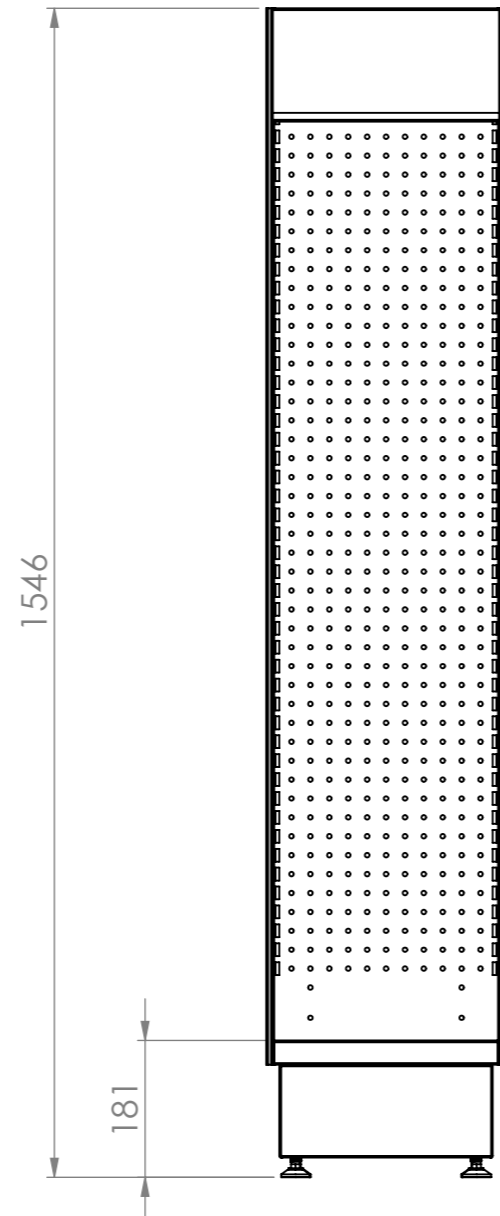
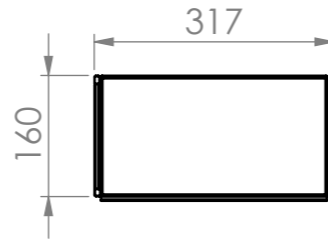
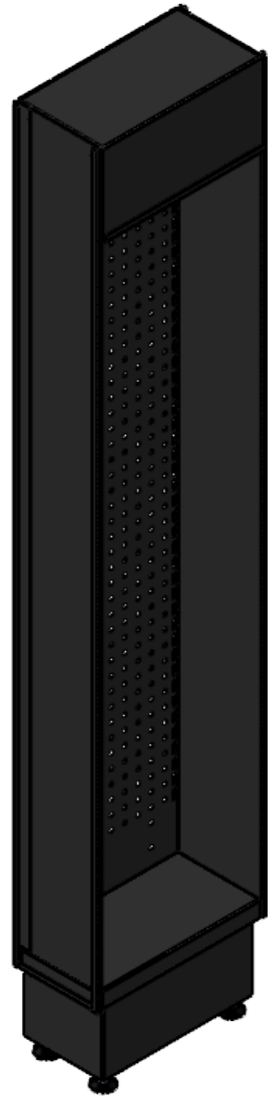

Rev	Date	Description

ALL DIMENSIONS IN (mm)  
UNLESS OTHERWISE SPECIFIED  
BREAK ALL SHARP EDGES

TOLERANCES  
(BEFORE PAINTING  
& AFTER PLATING)  
X ± 1.00  
X.X ± 0.50  
X.XX ± 0.10  
ANGLES ± 0.5°

**A03-DIMENSIONS**

CLIENT: --  
PROJ. NO.: TBA  
PART NO.: --  
Revision --  
Page 3

**290(W) x 1515(H) x 150(D) DENSE END**

PRODUCT CODE: **-RFA1093**

Date: 26/10/2022

Drawn by DH

Checked by --

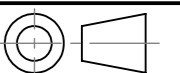

DO NOT SCALE

Scale@A3 1:10

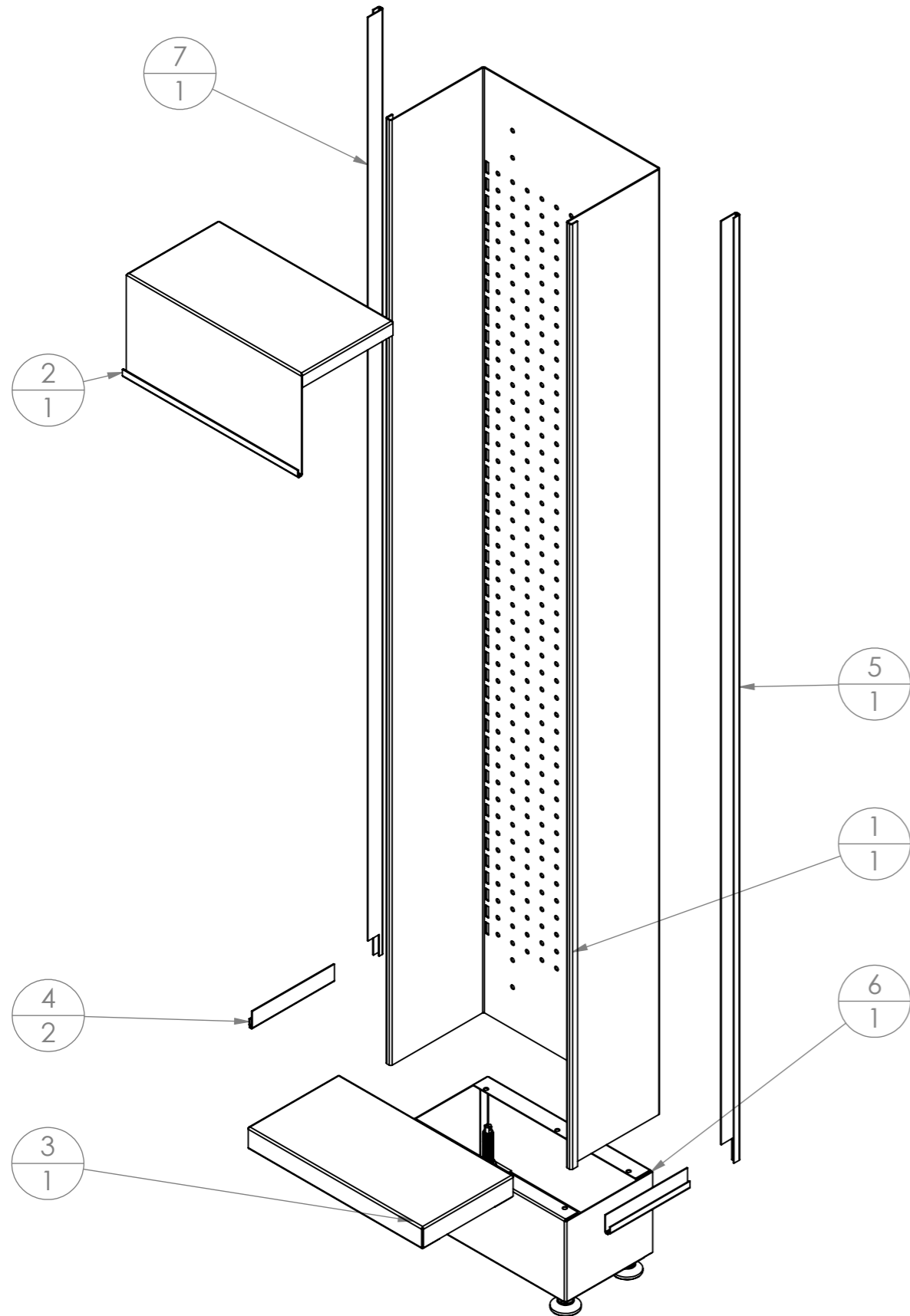

ITEM NO.	PartNo	DESCRIPTION	QTY.
1		290(W)x1515(H)x150(D) DENSE END PANEL	1
2		290(W)x150(H)x150(D) TOP COVER	1
3		290(W)x150(D) TOP OF BASE	1
4		140(D) BOTTOM SIGNAGE CHANNEL	2
5		1515(H) VERTICAL SIGNAGE CHANNEL	1
6		BASE OF DENSE END	1
7		MIRROR 1515(H) VERTICAL SIGNAGE CHANNEL	1

Rev	Date	Description

ALL DIMENSIONS IN (mm)  
UNLESS OTHERWISE SPECIFIED  
BREAK ALL SHARP EDGES

TOLERANCES  
(BEFORE PAINTING  
& AFTER PLATING)  
X ± 1.00  
X.X ± 0.50  
X.XX ± 0.10  
ANGLES ± 0.5°

**A012-EXPLODED**

CLIENT: --  
PROJ. NO.: TBA  
PART NO.: --  
Revision --  
Page 12

**RFA1093\_1515mm DENSE END**

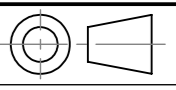
-		
PRODUCT CODE:	<b>RFA1093</b>	
Date:	26/10/2022	DO NOT SCALE
Drawn by	DH	
Checked by	--	Scale@A3 1:10