



Rev	Date	Description

ALL DIMENSIONS IN (mm)
UNLESS OTHERWISE SPECIFIED
BREAK ALL SHARP EDGES

TOLERANCES
(BEFORE PAINTING
& AFTER PLATING)
X ± 1.00
X.X ± 0.50
X.XX ± 0.10
ANGLES ± 0.5°

A01- RENDER
CLIENT: RFA1000
PROJ. NO.: TBA
PART NO.: --
Revision --
Page 1

900 MM (W) X 1515 MM (H) DOUBLE SIDED GONDOLA BAY - NON PERFORATED - ADD BAY		
PRODUCT CODE: RFA1087		
Date:	20/06/2023	DO NOT SCALE
Drawn by	DH	
Checked by	--	
		Scale@A3 1:20

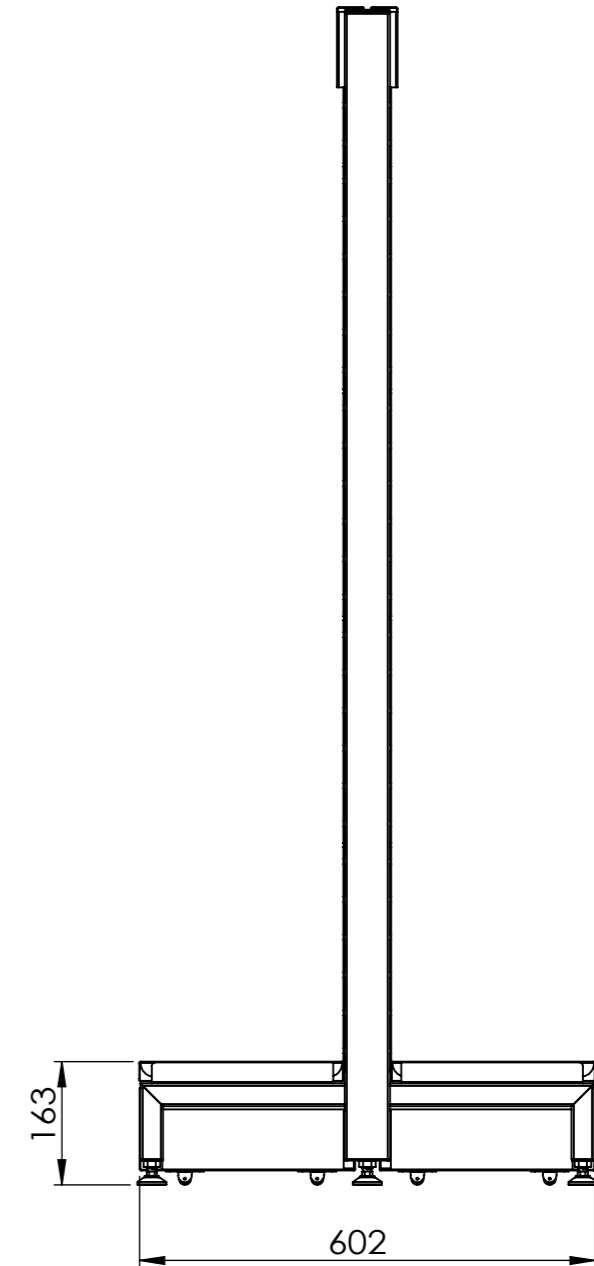
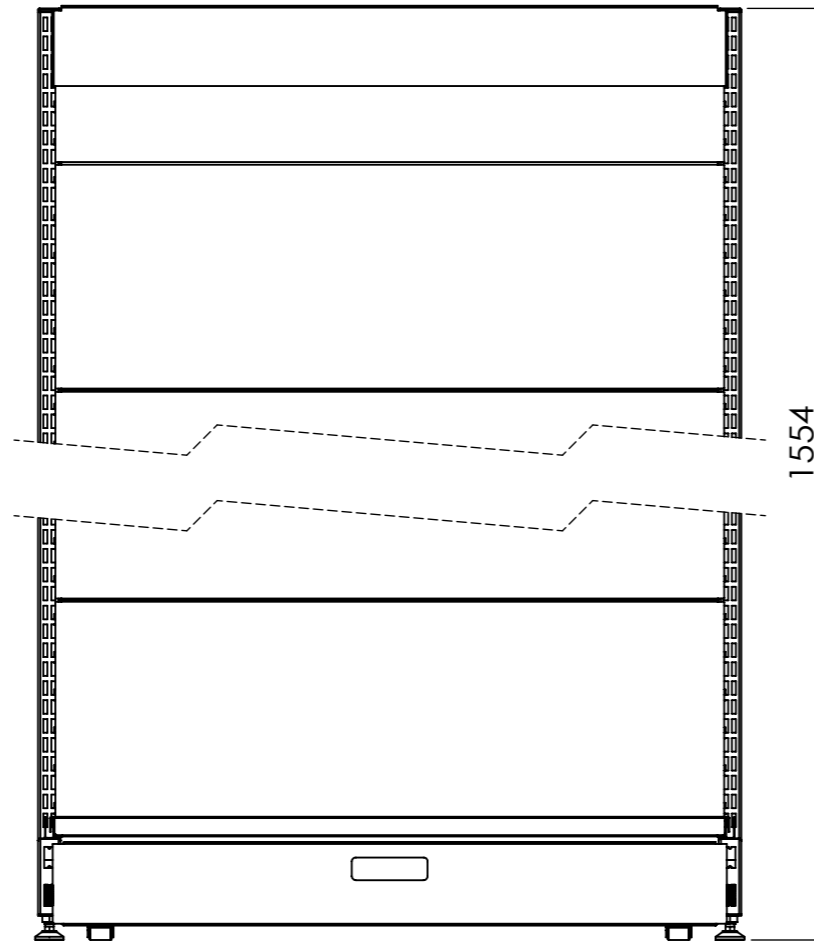
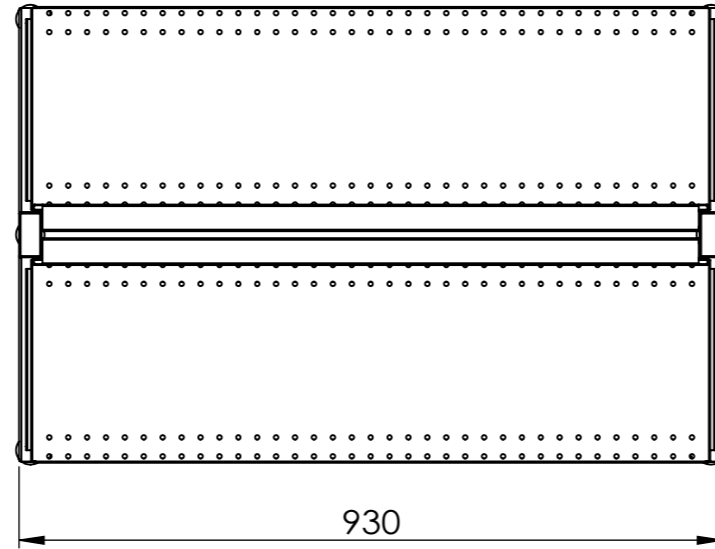
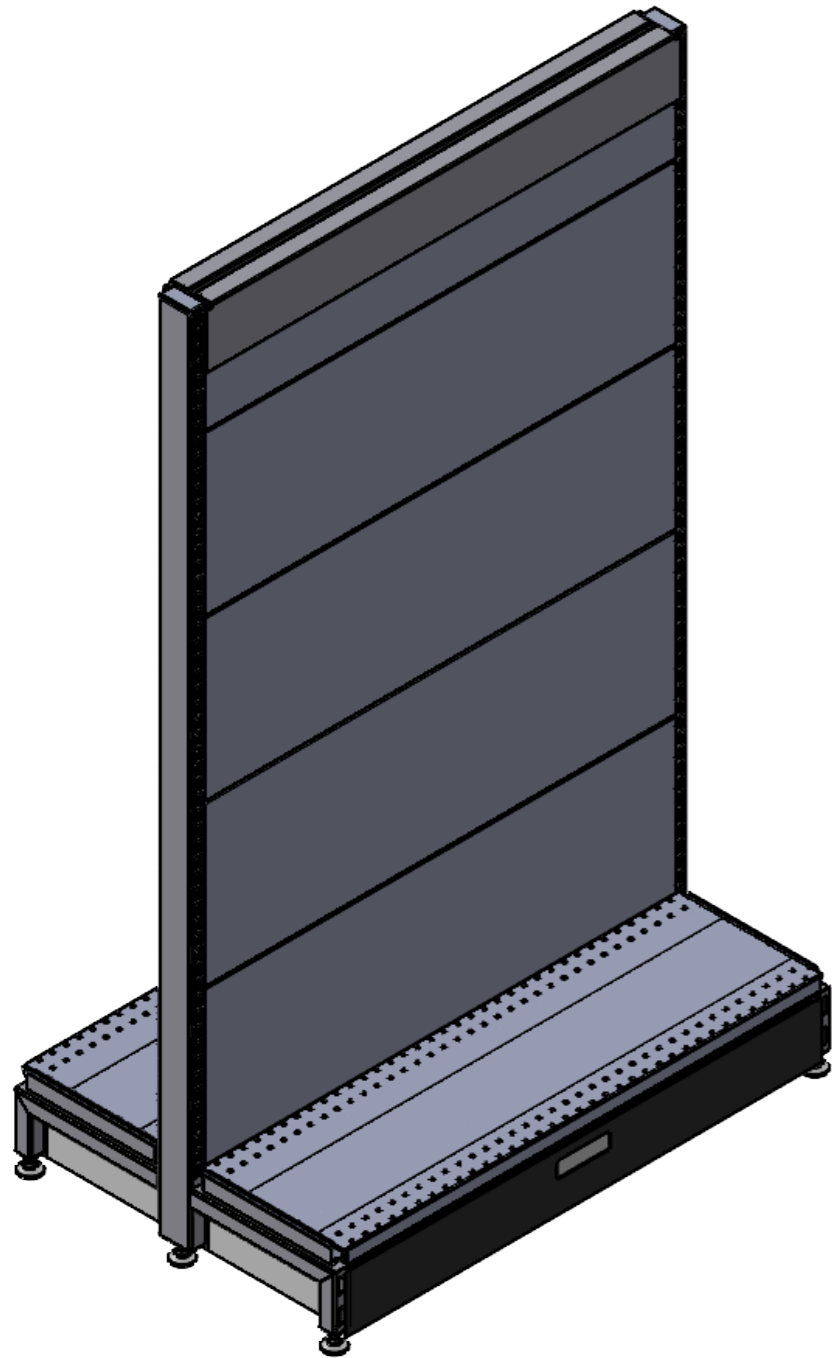

Rev	Date	Description

ALL DIMENSIONS IN (mm)
UNLESS OTHERWISE SPECIFIED
BREAK ALL SHARP EDGES

TOLERANCES
(BEFORE PAINTING
& AFTER PLATING)
X ± 1.00
X.X ± 0.50
X.XX ± 0.10
ANGLES ± 0.5°

A02- MECHANICAL
CLIENT: RFA1000
PROJ. NO.: TBA
PART NO.: --
Revision --
Page 2

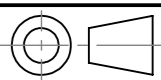
900 MM (W) X 1515 MM (H) DOUBLE SIDED GONDOLA BAY - NON PERFORATED - ADD BAY		 DO NOT SCALE
PRODUCT CODE: RFA1087	Date: 20/06/2023	
Drawn by: DH	Checked by: --	Scale@A3 1:15

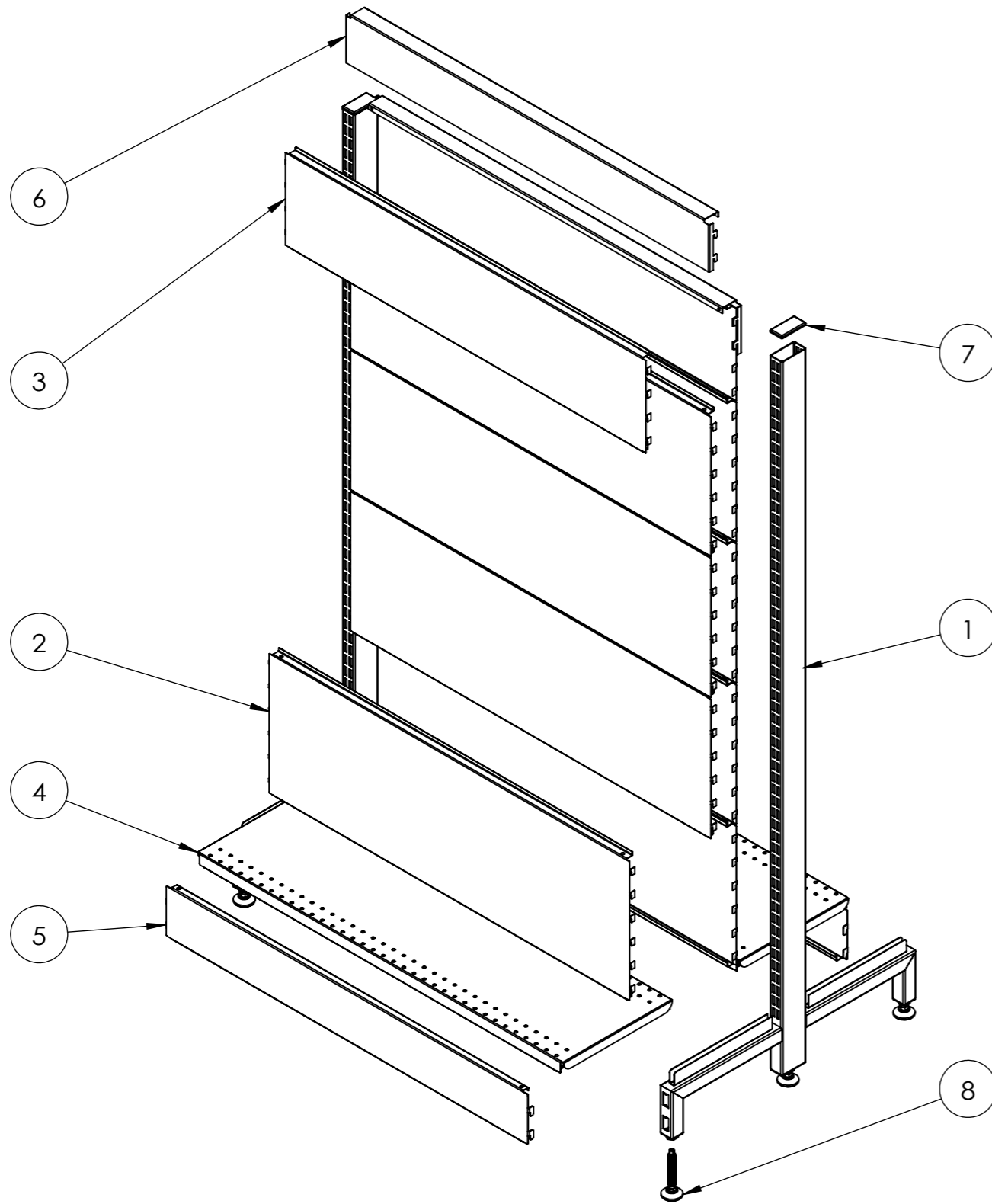

ITEM NO.	DESCRIPTION	QTY.
1	POST - DOUBLE SIDED GONDOLA - 1515 MM (H) - W/. 270 MM LEGS - MATTE BLACK	2
2	CLIP IN PANEL - 900(W) X 300(H) - NON PERFORATED - MATTE BLACK	8
3	CLIP IN PANEL - 900 MM (W) X 200 MM (H) - NON PERFORATED - MATTE BLACK	2
4	SHELF STEEL - 900 MM (W) X 270 MM (D) - BLACK	2
5	900 BOTTOM SKIRT	2
6	SNAP IN TOP CAP_BLACK	2
7	PLASTIC ENDCAP	2
8	M12 LEVELING FEET	6

Rev	Date	Description

ALL DIMENSIONS IN (mm)
UNLESS OTHERWISE SPECIFIED
BREAK ALL SHARP EDGES

TOLERANCES
(BEFORE PAINTING
& AFTER PLATING)
X ± 1.00
X.X ± 0.50
X.XX ± 0.10
ANGLES ± 0.5°

A09- EXPLODED
CLIENT: RFA1000
PROJ. NO.: TBA
PART NO.: --
Revision --
Page 9

900 MM (W) X 1515 MM (H) DOUBLE SIDED GONDOLA BAY - NON PERFORATED - ADD BAY

PRODUCT CODE: **RFA1087**

Date: 20/06/2023

Drawn by DH

Checked by --

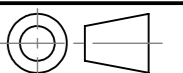

DO NOT SCALE

Scale@A3 1:20