



This product is an Add Bay
 * Supplied with (1) post only
 * Connects to the post of the neighboring Bay

Rev	Date	Description

ALL DIMENSIONS IN (mm)
 UNLESS OTHERWISE SPECIFIED
 BREAK ALL SHARP EDGES

TOLERANCES
 (BEFORE PAINTING
 & AFTER PLATING)
 X ± 1.00
 X.X ± 0.50
 X.XX ± 0.10
 ANGLES ± 0.5°

A01- RENDER
 CLIENT: RFA1000
 PROJ. NO.: TBA
 PART NO.: --
 Revision --
 Page 1

900 MM (W) X 1515 MM (H) DOUBLE SIDED
 GONDOLA BAY - PERFORATED - ADD BAY
 -

PRODUCT CODE: **RFA1086**

Date: 19/06/2023

Drawn by DH

Checked by --

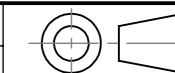

DO NOT SCALE

Scale@A3 1:20

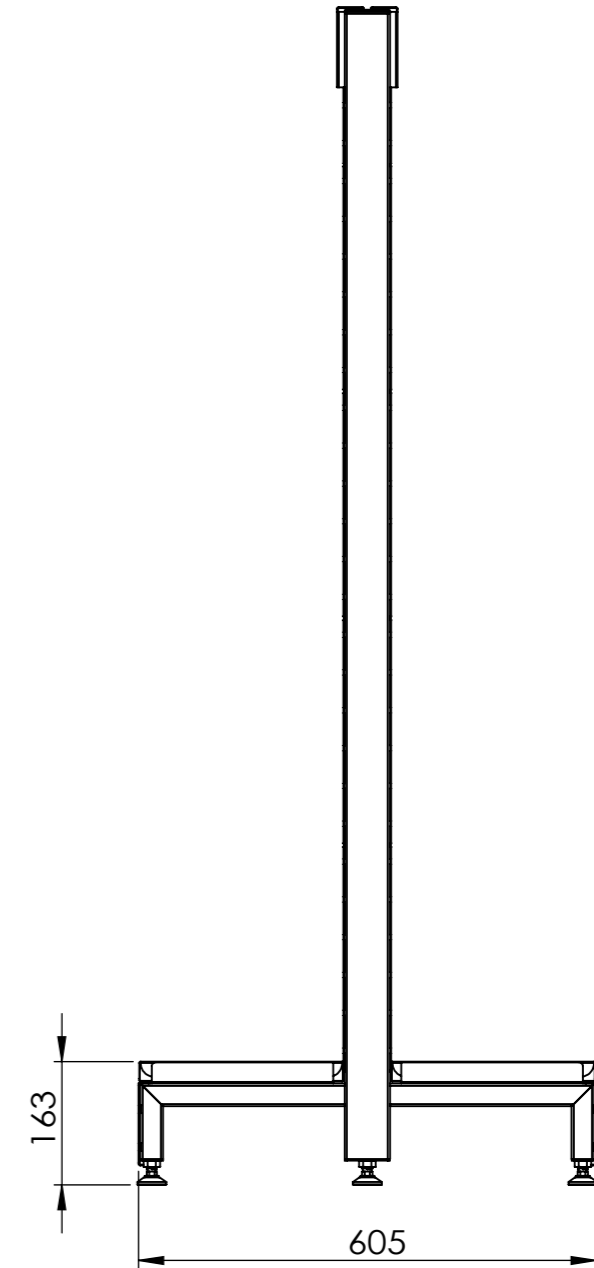
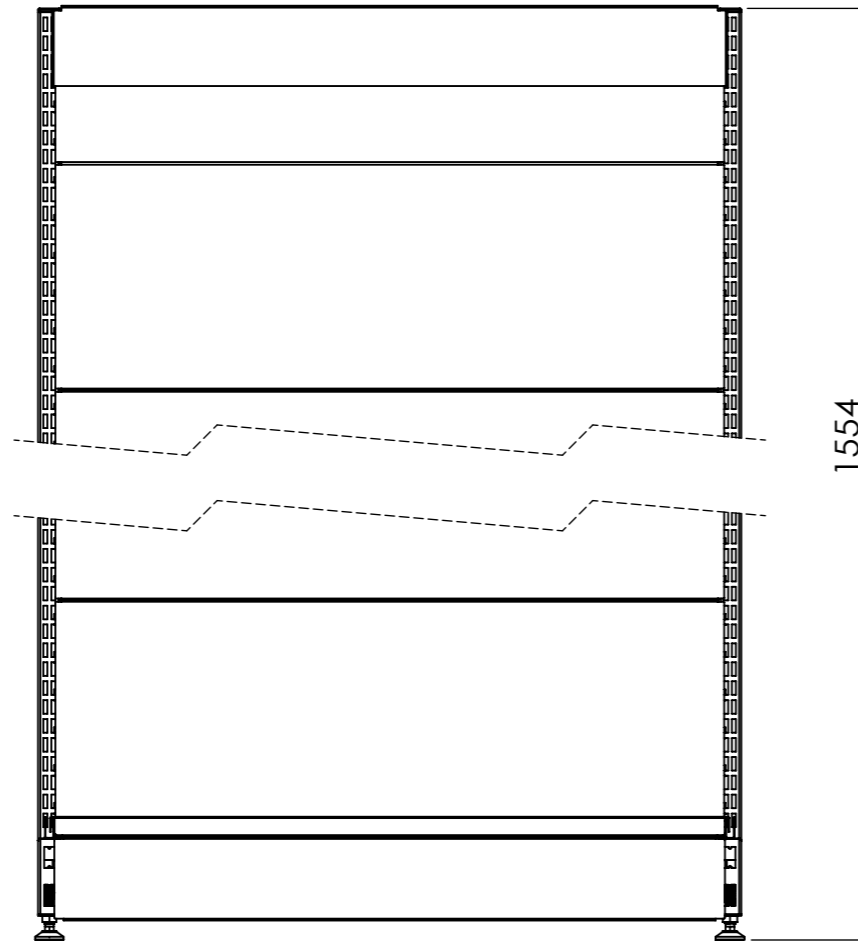
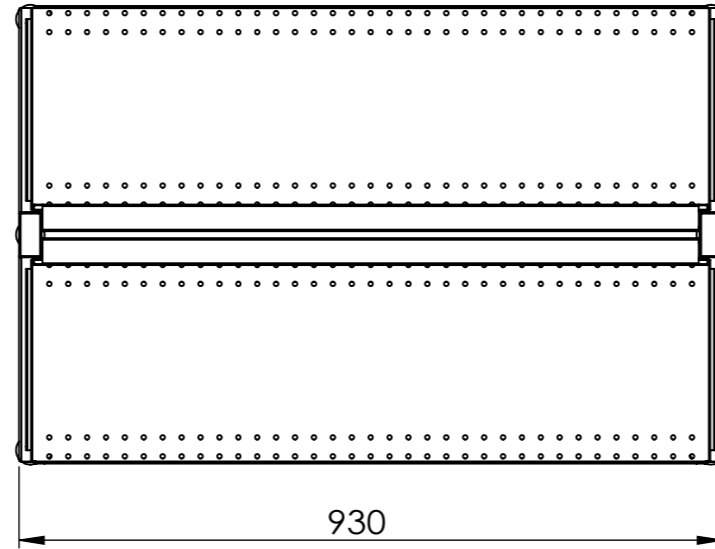
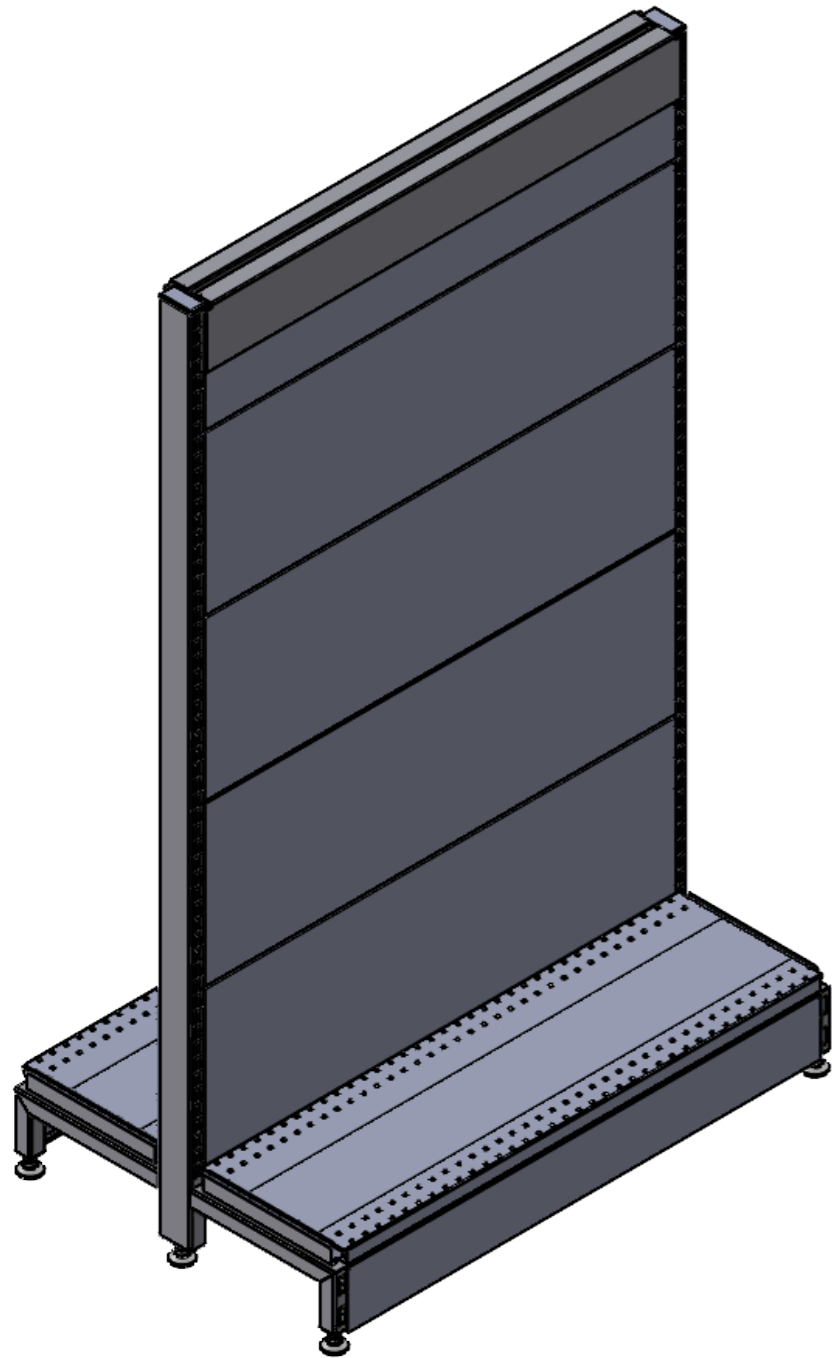

Rev	Date	Description

ALL DIMENSIONS IN (mm)
UNLESS OTHERWISE SPECIFIED
BREAK ALL SHARP EDGES

TOLERANCES
(BEFORE PAINTING
& AFTER PLATING)
X ± 1.00
X.X ± 0.50
X.XX ± 0.10
ANGLES ± 0.5°

A02- MECHANICAL
CLIENT: RFA1000
PROJ. NO.: TBA
PART NO.: --
Revision --
Page 2

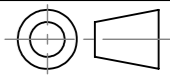
900 MM (W) X 1515 MM (H) DOUBLE SIDED GONDOLA BAY - PERFORATED - ADD BAY		 DO NOT SCALE
PRODUCT CODE: RFA1086	Date: 19/06/2023	
Drawn by: DH	Checked by: --	Scale@A3 1:15

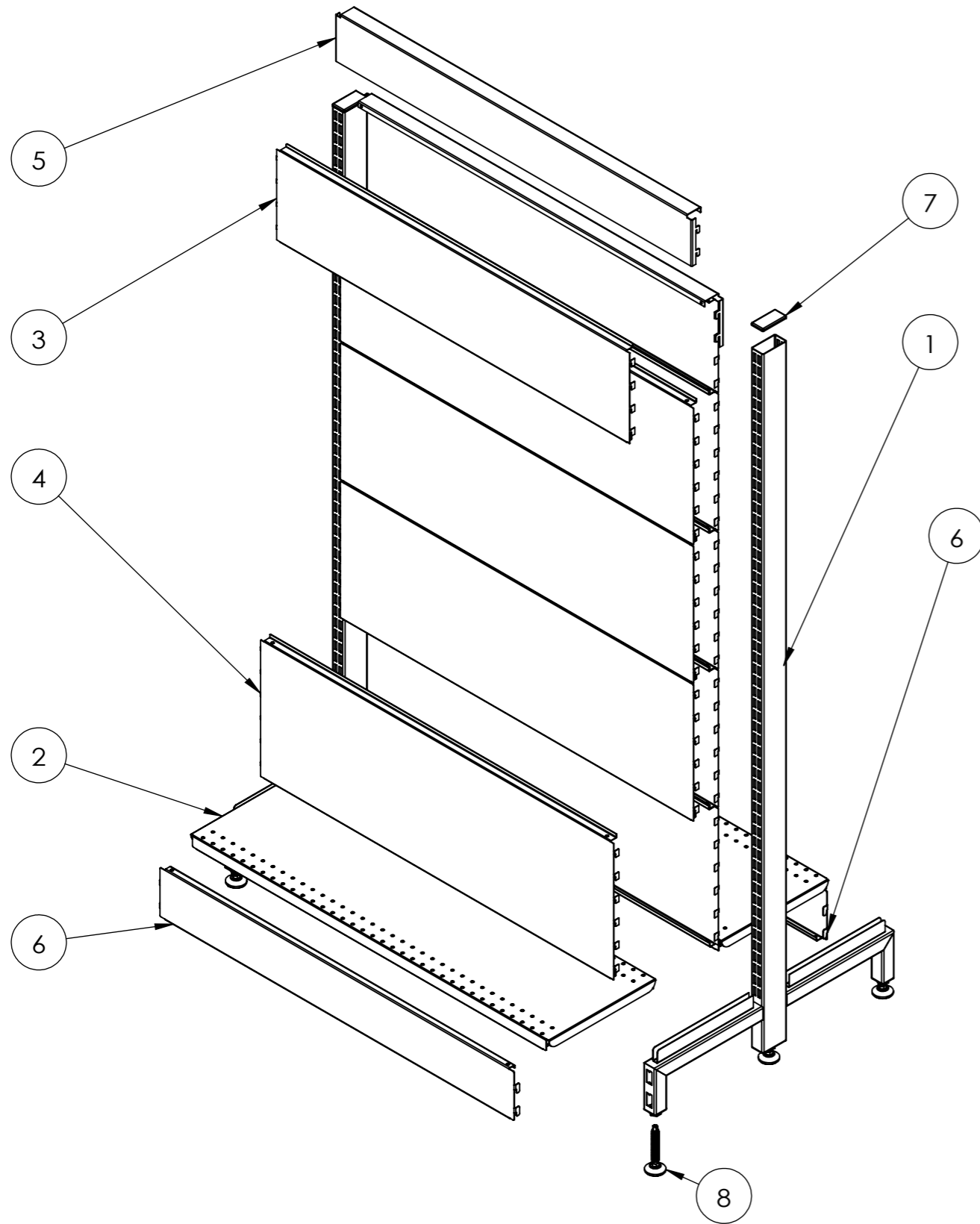

ITEM NO.	DESCRIPTION	QTY.
1	POST - DOUBLE SIDED GONDOLA - 1515 MM (H) - W/. 270 MM LEGS - PEARL WHITE	2
2	SHELF STEEL - 900 MM (W) X 270 MM (D) - BLACK	2
3	CLIP IN PANEL - 900 MM (W) X 200 MM (H) - NON PERFORATED - MATTE BLACK	2
4	CLIP IN PANEL - 900(W) X 300(H) - NON PERFORATED - MATTE BLACK	8
5	SNAP IN TOP CAP_BLACK	2
6	900 BOTTOM SKIRT	2
7	PLASTIC ENDCAP	2
8	M12 LEVELING FEET	6

Rev	Date	Description

ALL DIMENSIONS IN (mm)
UNLESS OTHERWISE SPECIFIED
BREAK ALL SHARP EDGES

TOLERANCES
(BEFORE PAINTING
& AFTER PLATING)
X ± 1.00
X.X ± 0.50
X.XX ± 0.10
ANGLES ± 0.5°

A09- EXPLODED
CLIENT: RFA1000
PROJ. NO.: TBA
PART NO.: --
Revision --
Page 9

900 MM (W) X 1515 MM (H) DOUBLE SIDED GONDOLA BAY - PERFORATED - ADD BAY

PRODUCT CODE: **RFA1086**

Date: 19/06/2023

Drawn by DH

Checked by --

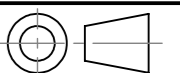

DO NOT SCALE

Scale@A3 1:20