

FINISH: MATTE BLACK

AP ASSOCIATED PROJECTS COMMERCIAL BUILDERS,
PROJECT MANAGERS,
PLANNERS & DESIGNERS

T 03 8787 3000 F 03 8787 3025
48-58 Cyber Loop, Dandenong South VIC 3175

Rev	Date	Description

ALL DIMENSIONS IN (mm)
UNLESS OTHERWISE SPECIFIED
BREAK ALL SHARP EDGES

TOLERANCES
(BEFORE PAINTING
& AFTER PLATING)
X ± 1.00
X.X ± 0.50
X.XX ± 0.10
ANGLES ± 0.5°

A01- RENDER
CLIENT: RFA1000
PROJ. NO.: TBA
PART NO.: --
Revision --
Page 1

600 X 1515 DOUBLE SIDED GONDOLA BAY - PERFORATED SKIRT DRAWER		
PRODUCT CODE: RFA1075	Date: 16/06/2023	
Drawn by: DH	Checked by: --	DO NOT SCALE
		Scale@A3 1:20

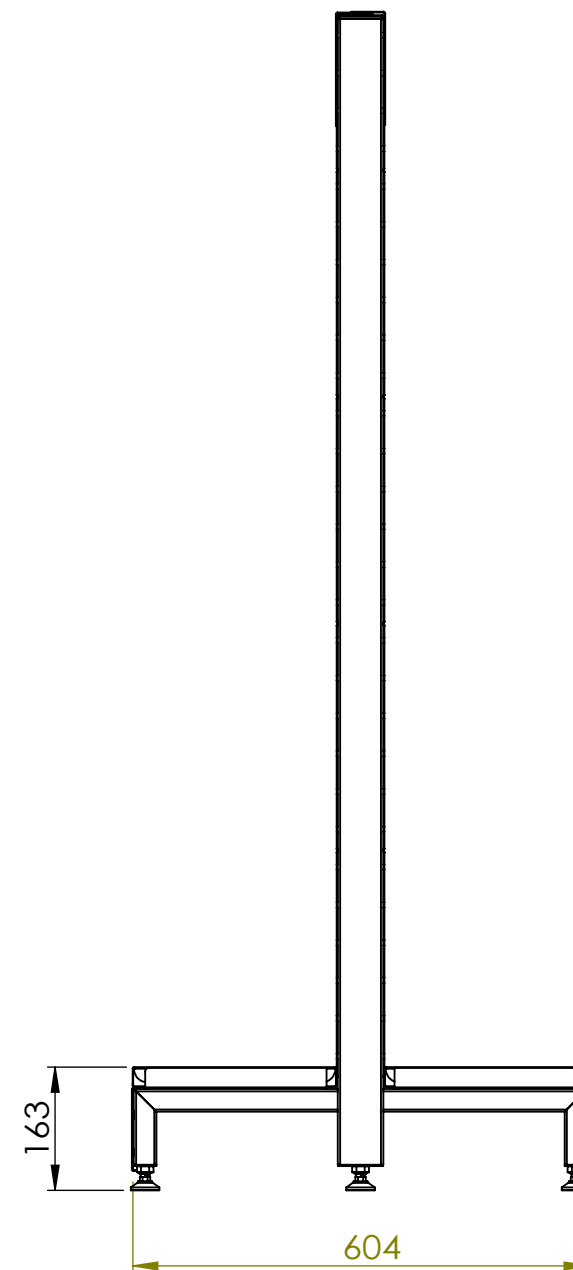
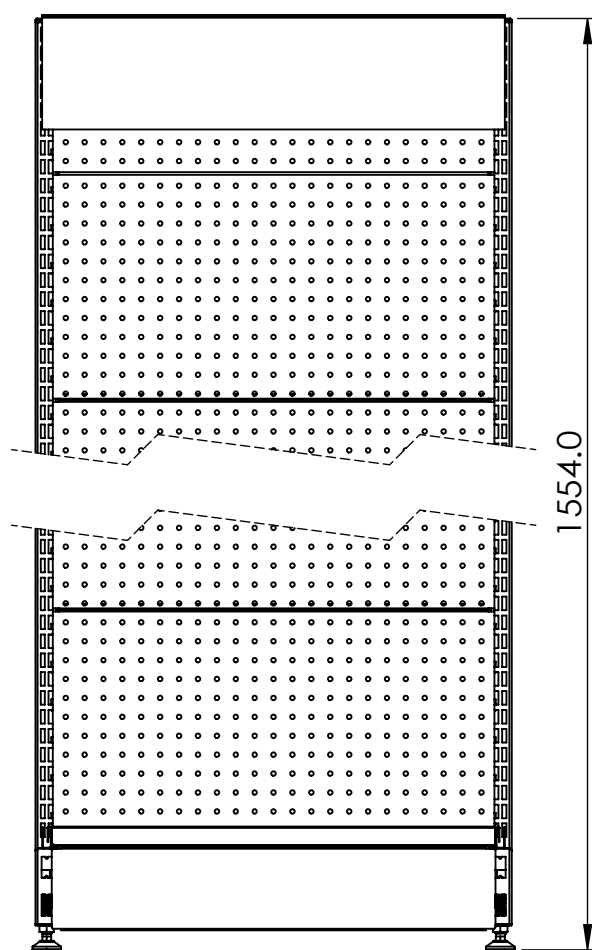
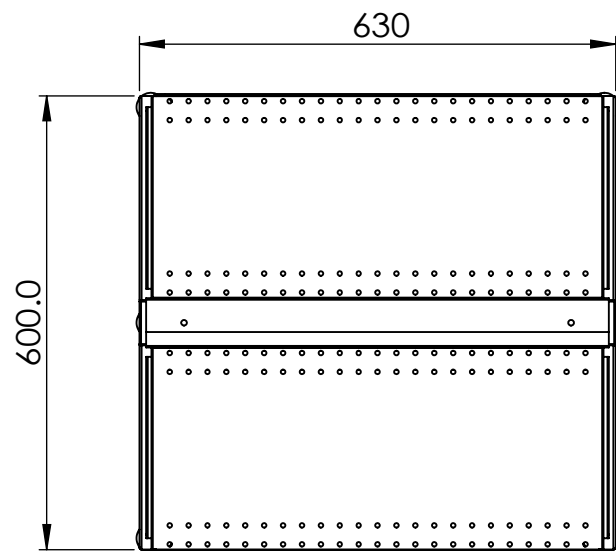
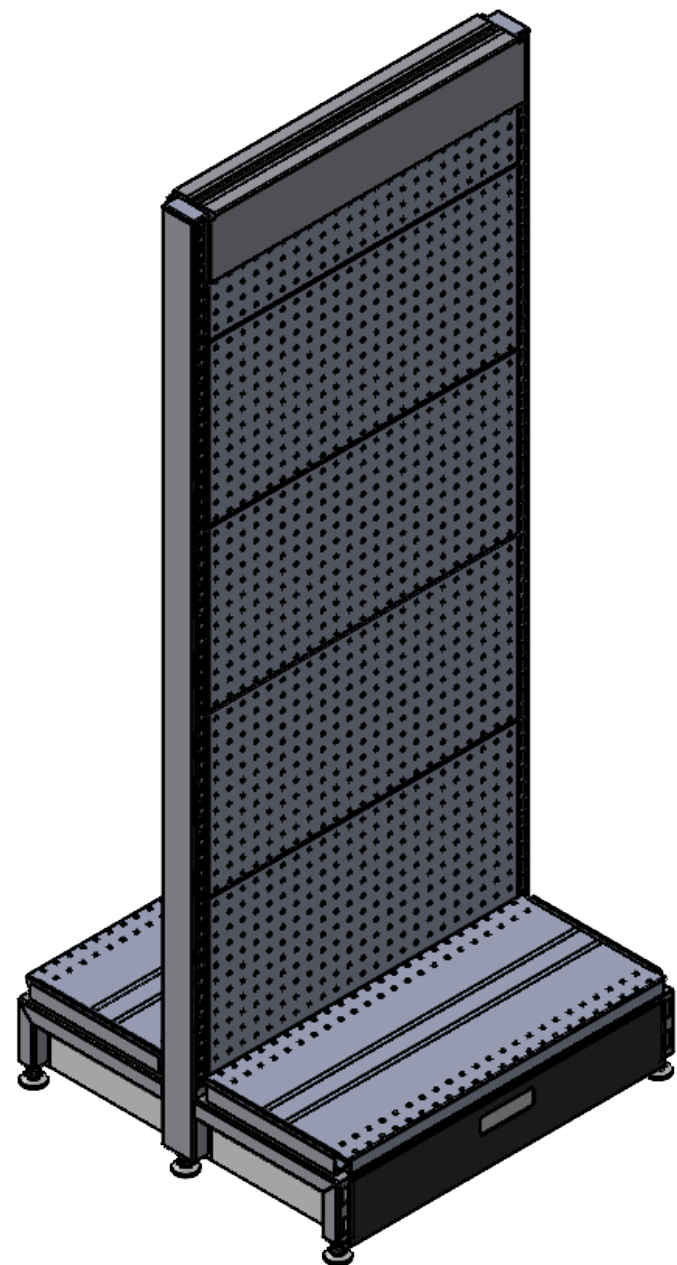

Rev	Date	Description

ALL DIMENSIONS IN (mm)
UNLESS OTHERWISE SPECIFIED
BREAK ALL SHARP EDGES

TOLERANCES
(BEFORE PAINTING
& AFTER PLATING)
X ± 1.00
X.X ± 0.50
X.XX ± 0.10
ANGLES ± 0.5°

A02- CLIENT
CLIENT: RFA1000
PROJ. NO.: TBA
PART NO.: --
Revision --
Page 2

600 X 1515 DOUBLE SIDED GONDOLA BAY - PERFORATED SKIRT DRAWER		
PRODUCT CODE: RFA1075	Date: 16/06/2023	
Drawn by: DH	Checked by: --	DO NOT SCALE
		Scale@A3 1:15

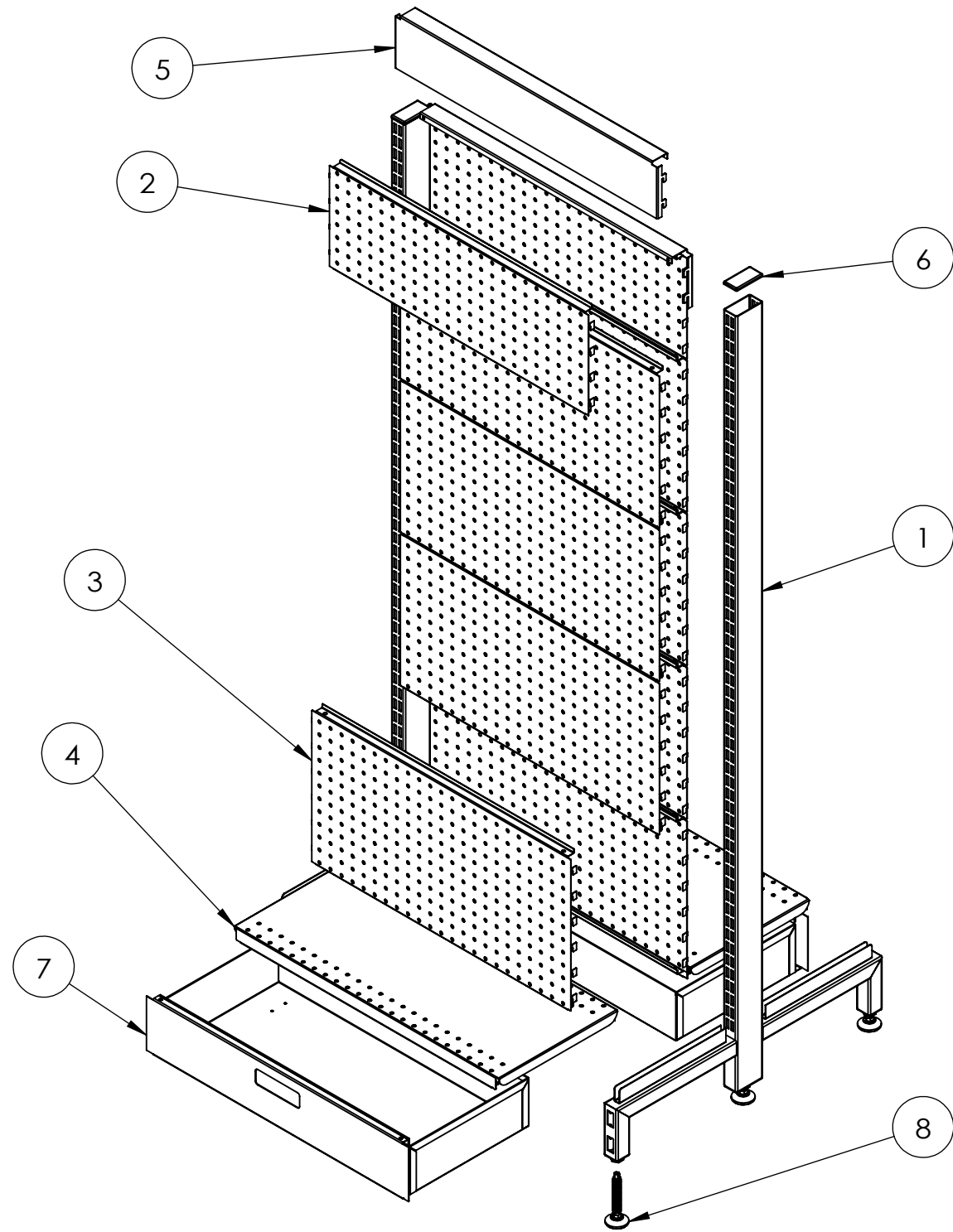

ITEM NO.	DESCRIPTION	QTY.
1	POST - DOUBLE SIDED GONDOLA - 1515 MM (H) - W/. 270 MM LEGS - PEARL WHITE	2
2	CLIP IN PANEL - 600 MM (W) X 200 MM (H) - PERFORATED - PEARL WHITE	2
3	CLIP IN PANEL - 600(W) X 300 H) - PERFORATED - PEARL WHITE	8
4	SHELF STEEL - 600 MM (W) X 270 MM (D) - PEARL WHITE	2
5	SNAP IN TOP CAP	2
6	PLASTIC ENDCAP	2
7	SKIRT DRAWER BOX - 600mm	2
8	M12 LEVELING FEET	6

Rev	Date	Description

ALL DIMENSIONS IN (mm)
UNLESS OTHERWISE SPECIFIED
BREAK ALL SHARP EDGES

TOLERANCES
(BEFORE PAINTING
& AFTER PLATING)
X ± 1.00
X.X ± 0.50
X.XX ± 0.10
ANGLES ± 0.5°

A09- EXPLODED VIEW

CLIENT: RFA1000

PROJ. NO.: TBA

PART NO.: --

Revision --

Page 9

600 X 1515 DOUBLE SIDED GONDOLA BAY - PERFORATED SKIRT DRAWER

PRODUCT CODE: **RFA1075**

Date: 16/06/2023

Drawn by DH

Checked by --

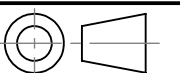

DO NOT SCALE

Scale@A3 1:20