

FINISH: P/C PEARL WHITE

AP ASSOCIATED PROJECTS COMMERCIAL BUILDERS,
PROJECT MANAGERS,
PLANNERS & DESIGNERS

T 03 8787 3000 F 03 8787 3025
48-58 Cyber Loop, Dandenong South VIC 3175

Rev	Date	Description

ALL DIMENSIONS IN (mm)
UNLESS OTHERWISE SPECIFIED
BREAK ALL SHARP EDGES

TOLERANCES
(BEFORE PAINTING
& AFTER PLATING)
X ± 1.00
X.X ± 0.50
X.XX ± 0.10
ANGLES ± 0.5°

A01- RENDER

CLIENT: RFA

PROJ. NO.: TBA

PART NO.: --

Revision --

Page 1

END PANEL - GONDOLA END - PERFORATED
W630 x H1515

PRODUCT CODE: **RFA1055**

Date: 10/10/2024

Drawn by PS

Checked by --

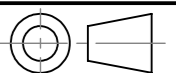

DO NOT SCALE

Scale@A3 1:20

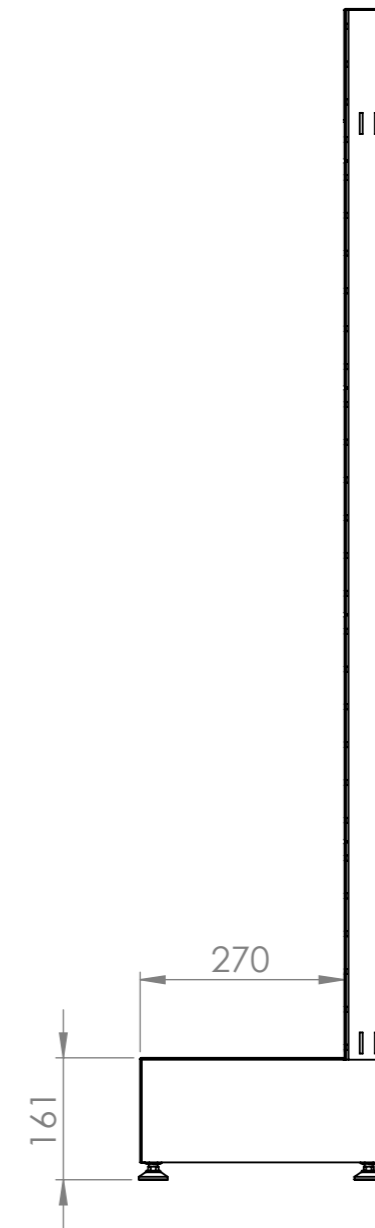
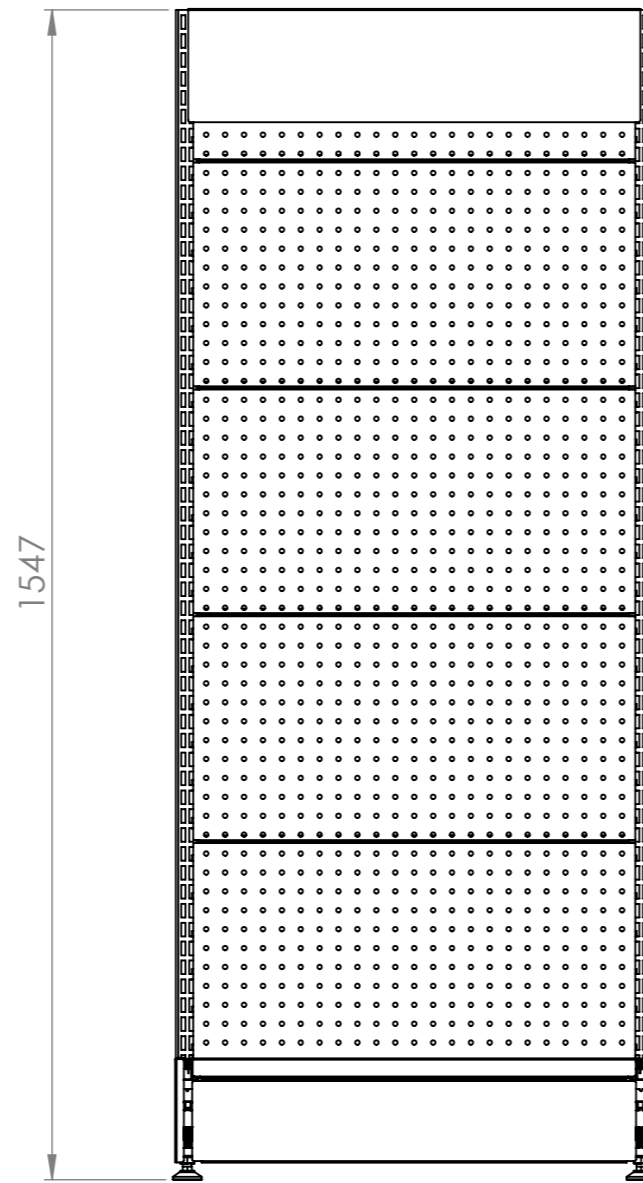
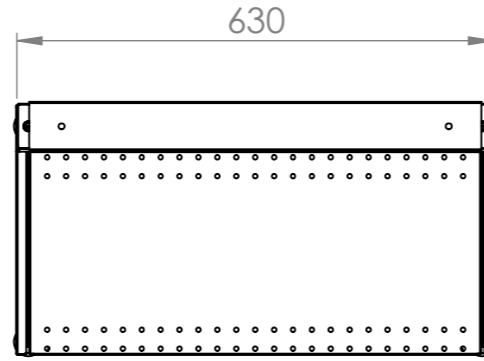
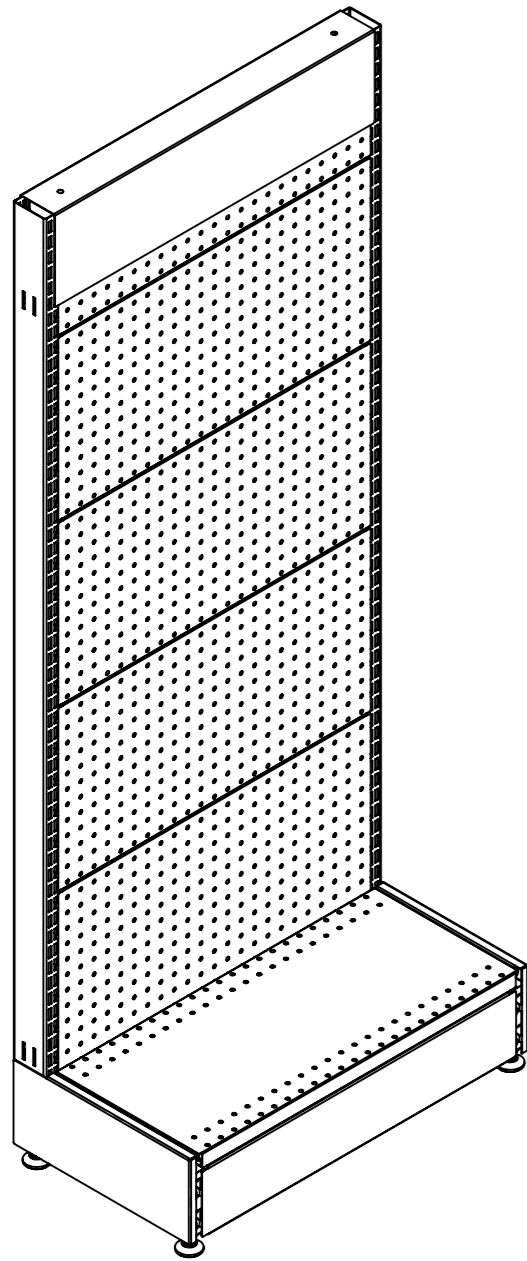

Rev	Date	Description

ALL DIMENSIONS IN (mm)
UNLESS OTHERWISE SPECIFIED
BREAK ALL SHARP EDGES

TOLERANCES
(BEFORE PAINTING
& AFTER PLATING)
X ± 1.00
X.X ± 0.50
X.XX ± 0.10
ANGLES ± 0.5°

A02- DIMENSIONS

CLIENT: RFA
PROJ. NO.: TBA
PART NO.: --
Revision --
Page 2

END PANEL - GONDOLA END - PERFORATED
W630 x H1515

PRODUCT CODE: **RFA1055**

Date: 10/10/2024

Drawn by PS

Checked by --

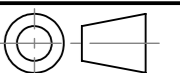

DO NOT SCALE

Scale@A3 1:10

ITEM NO.	PartNo	DESCRIPTION	QTY.
1	AP1039	POST SINGLE SIDED GONDOLA	2
2	AP1034	CLIP IN PANEL - W600 X H300 - PERFORATED	4
3	AP1035	CLIP IN PANEL - W600xH200 - PERFORATED	1
4	AP1041	SHELF - STEEL W600xD270	1
5	AP1031	SKIRT- W600xH110	1
6	AP1053	CLIP IN PANEL - W600xH300 - NON PERFORATED	4
7	AP1054	CLIP IN PANEL - W600xH200 - NON PERFORATED	1
8	AP1038	TOP CAP W600	1
9	AP1032	SKIRT - LHS - W330xH110	1
10	AP1033	SKIRT - RHS - W330xH110	1

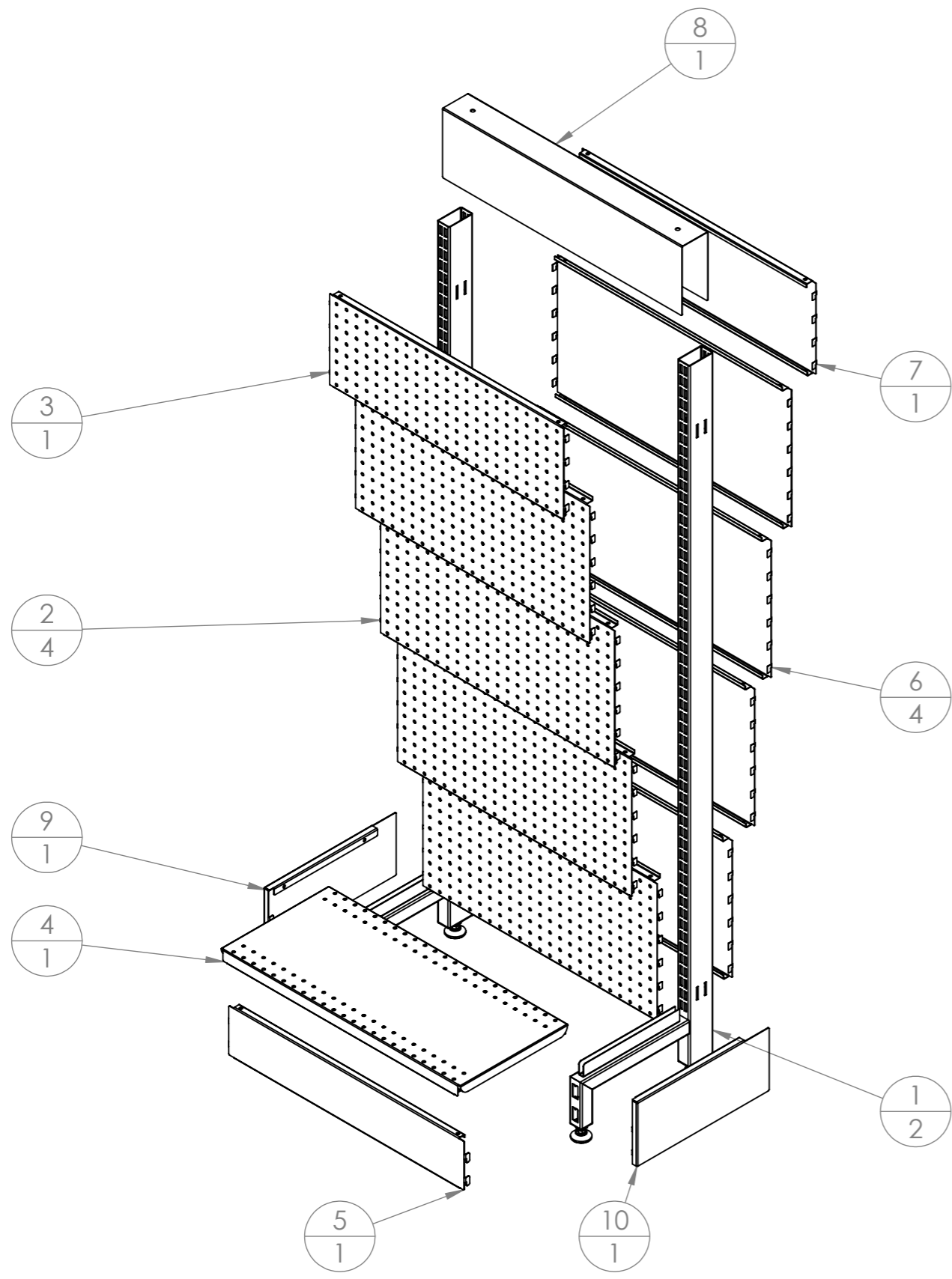

AP ASSOCIATED PROJECTS COMMERCIAL BUILDERS,
PROJECT MANAGERS,
PLANNERS & DESIGNERS

T 03 8787 3000 F 03 8787 3025
48-58 Cyber Loop, Dandenong South VIC 3175

Rev	Date	Description

ALL DIMENSIONS IN (mm)
UNLESS OTHERWISE SPECIFIED
BREAK ALL SHARP EDGES

TOLERANCES
(BEFORE PAINTING
& AFTER PLATING)
X ± 1.00
X.X ± 0.50
X.XX ± 0.10
ANGLES ± 0.5°

A03- EXPLODED
CLIENT: RFA
PROJ. NO.: TBA
PART NO.: --
Revision --
Page 3

END PANEL - GONDOLA END - PERFORATED
W630 x H1515

PRODUCT CODE: **RFA1055**

Date: 10/10/2024
Drawn by PS
Checked by --

DO NOT SCALE
Scale@A3 1:10