

Rev	Date	Description

ALL DIMENSIONS IN (mm)  
UNLESS OTHERWISE SPECIFIED  
BREAK ALL SHARP EDGES

TOLERANCES  
(BEFORE PAINTING  
& AFTER PLATING)  
X ± 1.00  
X.X ± 0.50  
X.XX ± 0.10  
ANGLES ± 0.5°

A01- RENDER

CLIENT: RFA1000

PROJ. NO.: TBA

PART NO.: --

Revision --

Page 1

900mm(W)x1515mm(H)x270mm(D)  
DOUBLE SIDED GONDOLA BAY-NON PERFORATED  
SLIMLINE - START BAY (PEARL WHITE)

PRODUCT CODE: **RFA1048**

Date: 17/06/2023

Drawn by DH

Checked by --

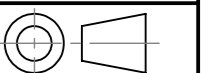

DO NOT SCALE

Scale@A3 1:20

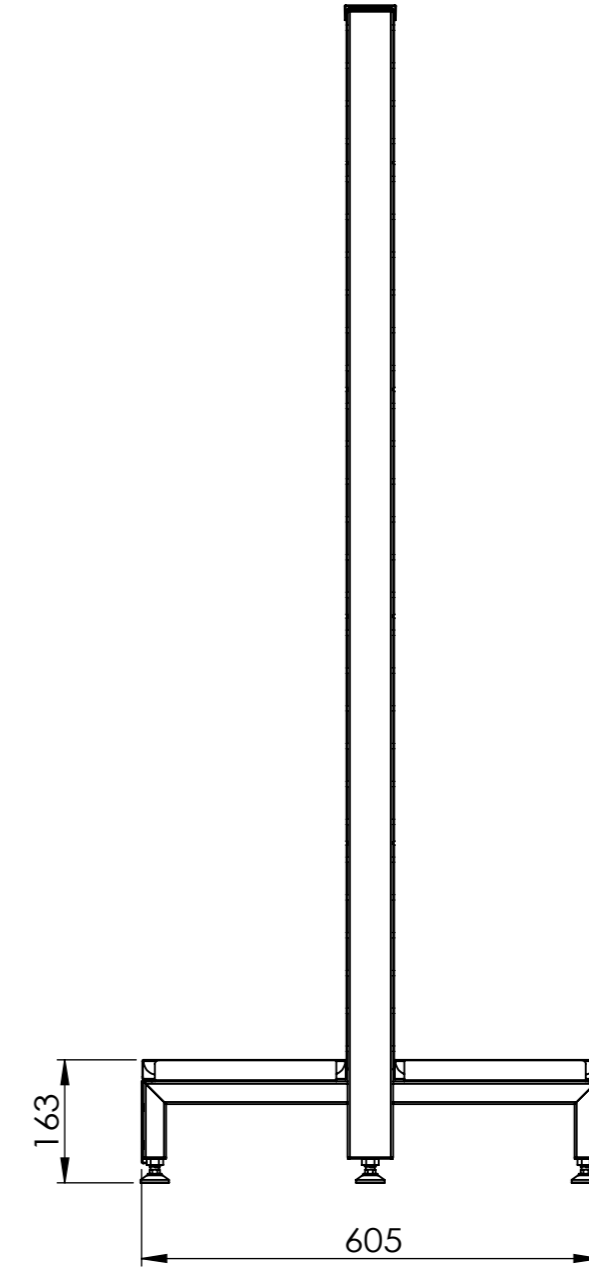
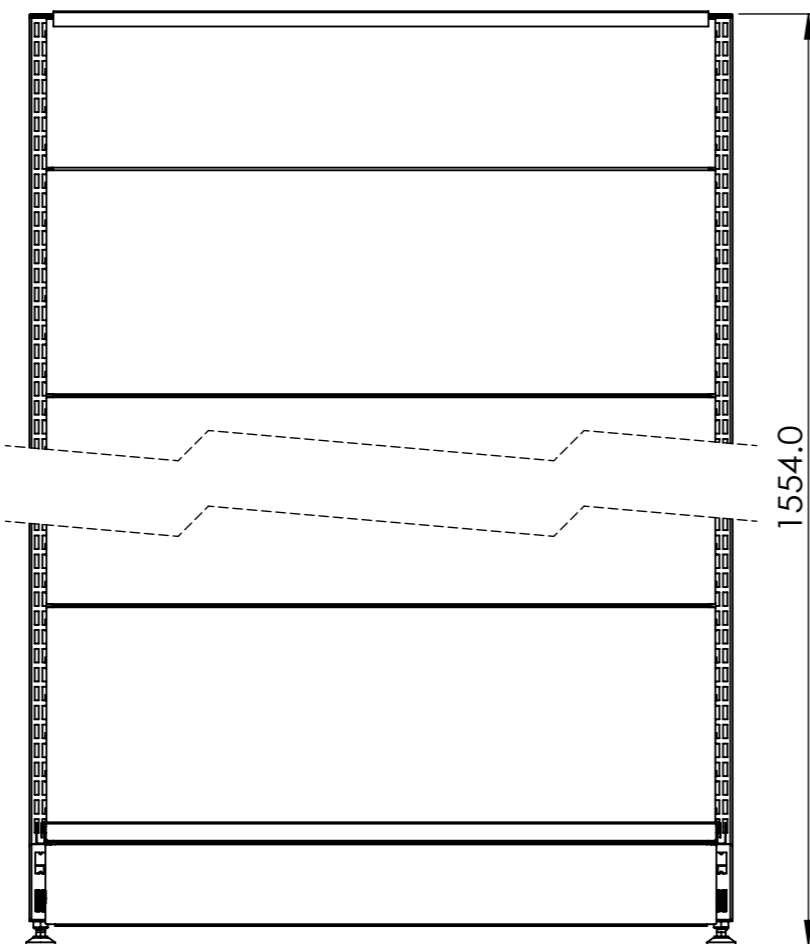
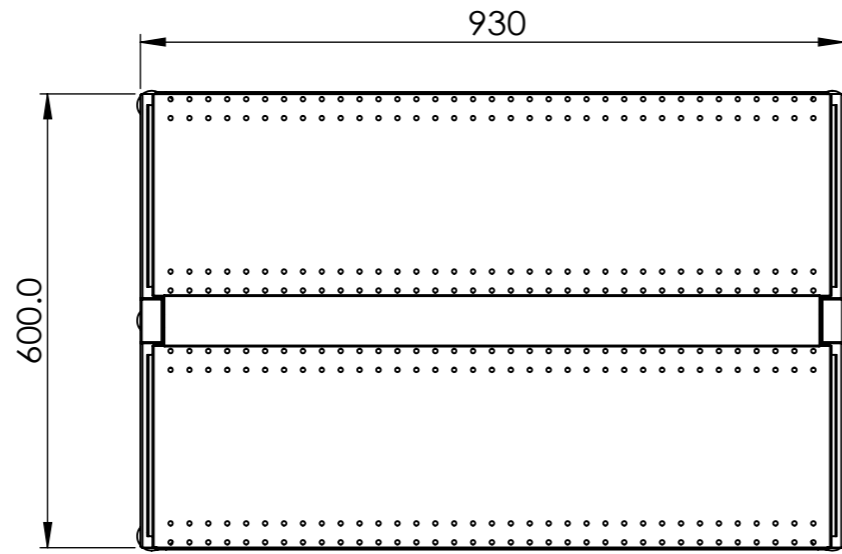
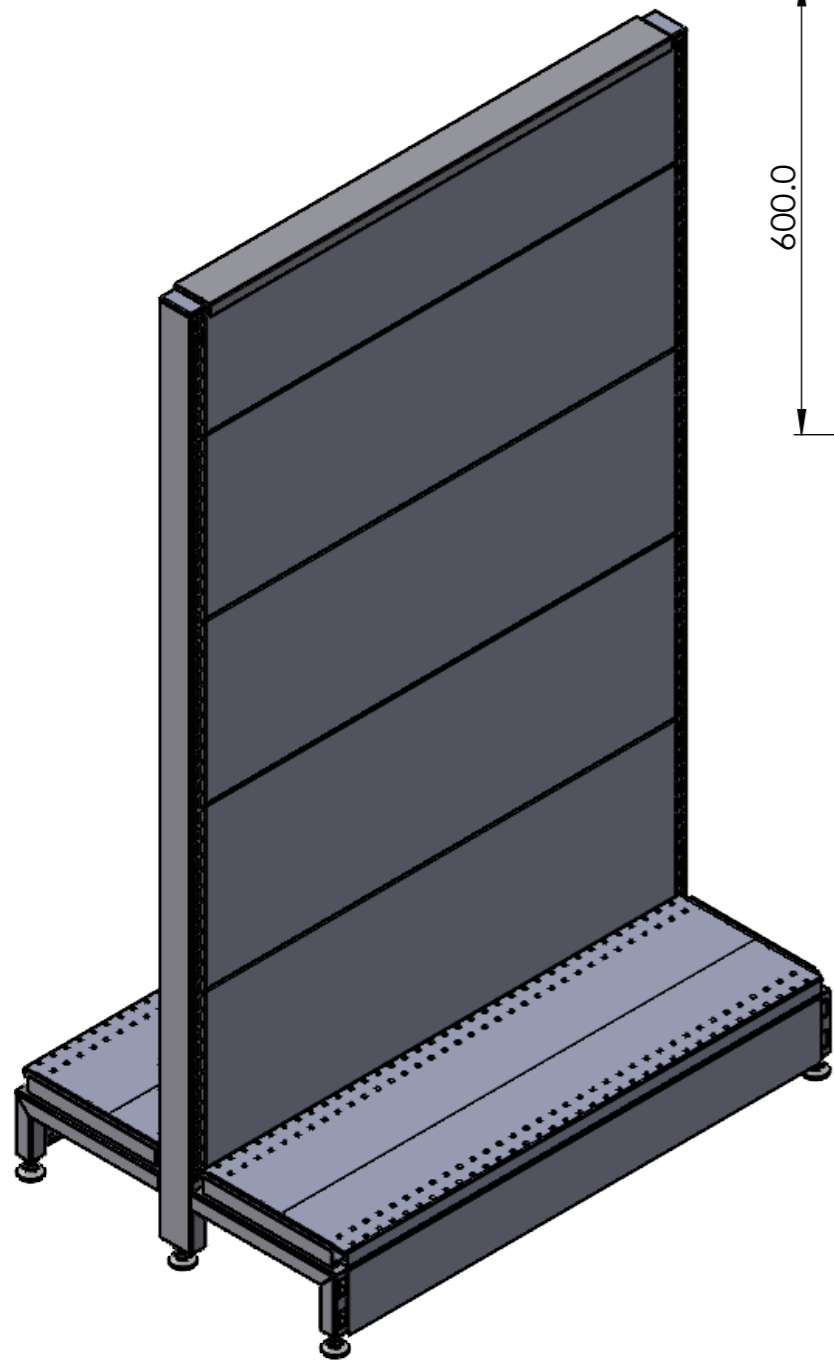

**AP ASSOCIATED PROJECTS** COMMERCIAL BUILDERS,  
PROJECT MANAGERS,  
PLANNERS & DESIGNERS

T 03 8787 3000 F 03 8787 3025  
48-58 Cyber Loop, Dandenong South VIC 3175

Rev	Date	Description

ALL DIMENSIONS IN (mm)  
UNLESS OTHERWISE SPECIFIED  
BREAK ALL SHARP EDGES

TOLERANCES  
(BEFORE PAINTING  
& AFTER PLATING)  
X ± 1.00  
X.X ± 0.50  
X.XX ± 0.10  
ANGLES ± 0.5°

A02- CLIENT  
CLIENT: RFA1000  
PROJ. NO.: TBA  
PART NO.: --  
Revision --  
Page 2

900mm(W)x1515mm(H)x270mm(D)  
DOUBLE SIDED GONDOLA BAY-NON PERFORATED  
SLIMLINE - START BAY (PEARL WHITE)

PRODUCT CODE: **RFA1048**

Date: 17/06/2023  
Drawn by: DH  
Checked by: --

DO NOT SCALE  
Scale@A3 1:15

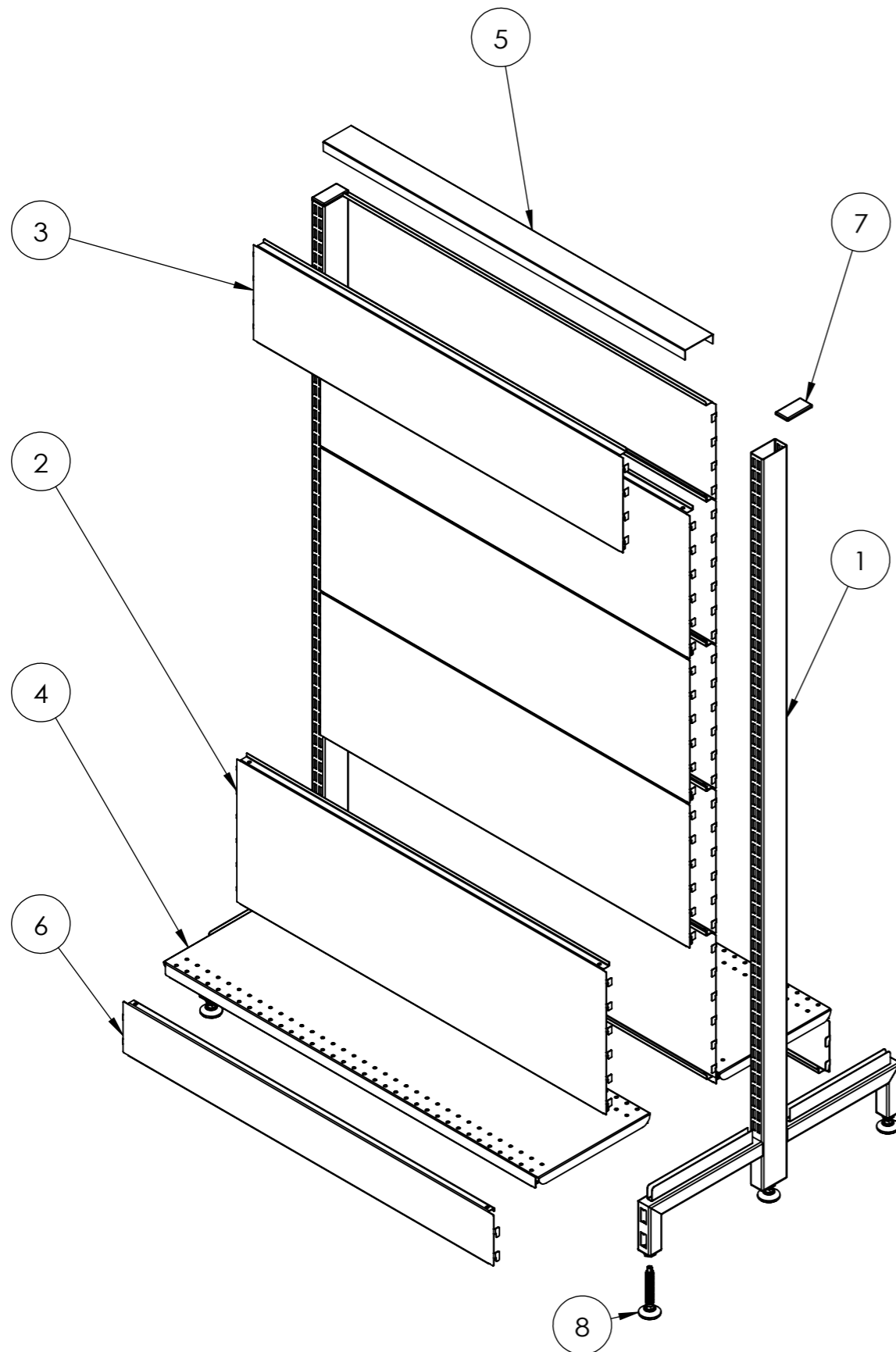

ITEM NO.	DESCRIPTION	QTY.
1	POST - DOUBLE SIDED GONDOLA - 1515 MM (H) - W/. 270 MM LEGS - PEARL WHITE	2
2	CLIP IN PANEL - 900(W) X 300(H) - NON PERFORATED - PEARL WHITE	8
3	CLIP IN PANEL - 900 MM (W) X 200 MM (H) - NON PERFORATED - PEARL WHITE	2
4	SHELF STEEL - 900 MM (W) X 270 MM (D) - PEARL WHITE	2
5	900 MM (W) SLIMLINE INTERNAL TOP CAP CLIPPER - FOR DDS	1
6	900 BOTTOM SKIRT	2
7	PLASTIC ENDCAP	2
8	M12 LEVELING FEET	6

Rev	Date	Description

ALL DIMENSIONS IN (mm)  
UNLESS OTHERWISE SPECIFIED  
BREAK ALL SHARP EDGES

TOLERANCES  
(BEFORE PAINTING  
& AFTER PLATING)  
X ± 1.00  
X.X ± 0.50  
X.XX ± 0.10  
ANGLES ± 0.5°

A09- EXPLODED  
CLIENT: RFA1000  
PROJ. NO.: TBA  
PART NO.: --  
Revision --  
Page 9

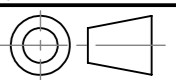
900mm(W)x1515mm(H)x270mm(D) DOUBLE SIDED GONDOLA BAY-NON PERFORATED SLIMLINE - START BAY (PEARL WHITE)		
PRODUCT CODE: <b>RFA1048</b>		
Date:	17/06/2023	DO NOT SCALE
Drawn by	DH	
Checked by	--	
		Scale@A3 1:20