

This product is an Add Bay
 * Supplied with (1) post Only
 * Connects to the post of the neighboring Bay

Rev	Date	Description

ALL DIMENSIONS IN (mm)
 UNLESS OTHERWISE SPECIFIED
 BREAK ALL SHARP EDGES

TOLERANCES
 (BEFORE PAINTING
 & AFTER PLATING)
 X ± 1.00
 X.X ± 0.50
 X.XX ± 0.10
 ANGLES ± 0.5°

A01- RENDER
 CLIENT: RFA1000
 PROJ. NO.: TBA
 PART NO.: --
 Revision --
 Page 1

600mm(W)x1515mm(H)x270mm(D)
 DOUBLE SIDED GONDOLA BAY-NON PERFORATED
 SLIMLINE - ADD BAY (PEARL WHITE)

PRODUCT CODE: RFA1047	
Date: 13/06/2023	
Drawn by DH	DO NOT SCALE
Checked by --	Scale@A3 1:20

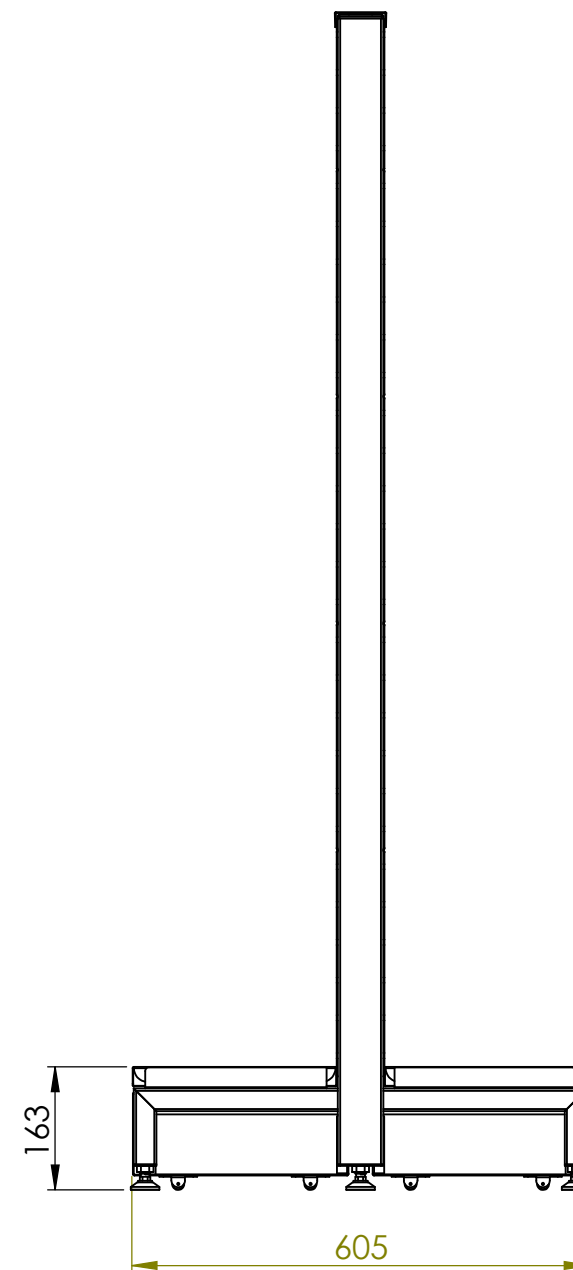
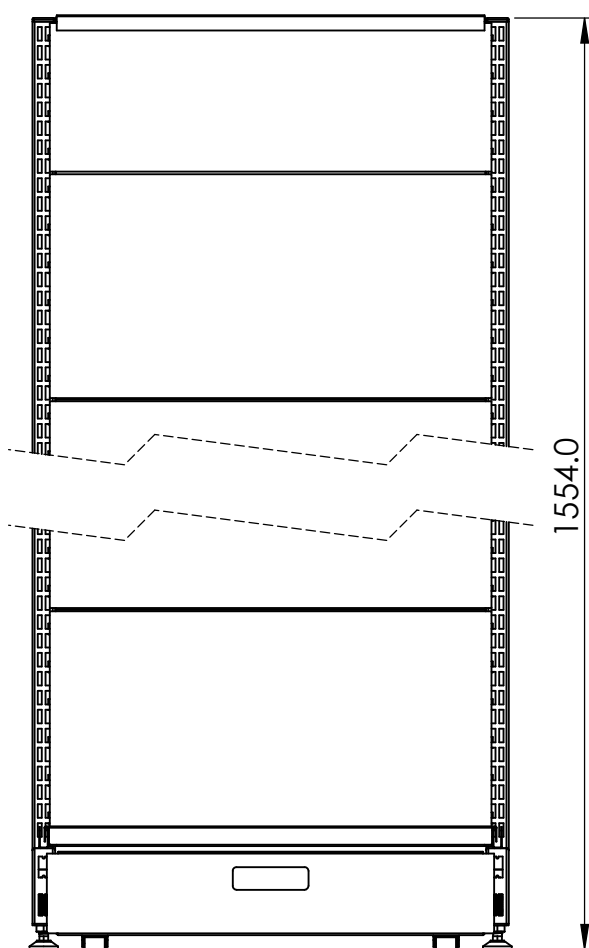
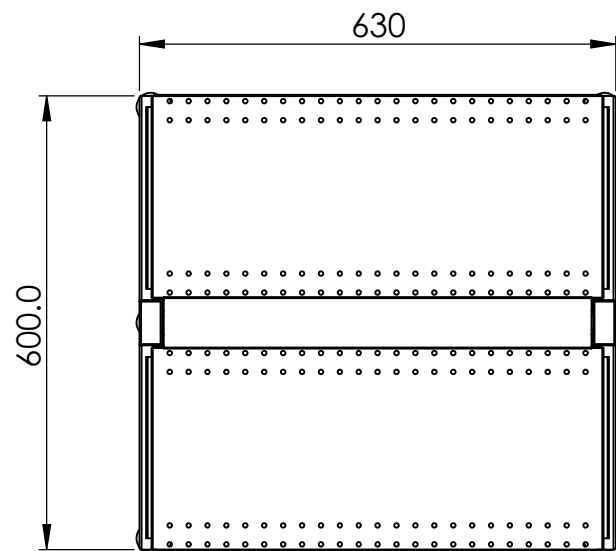
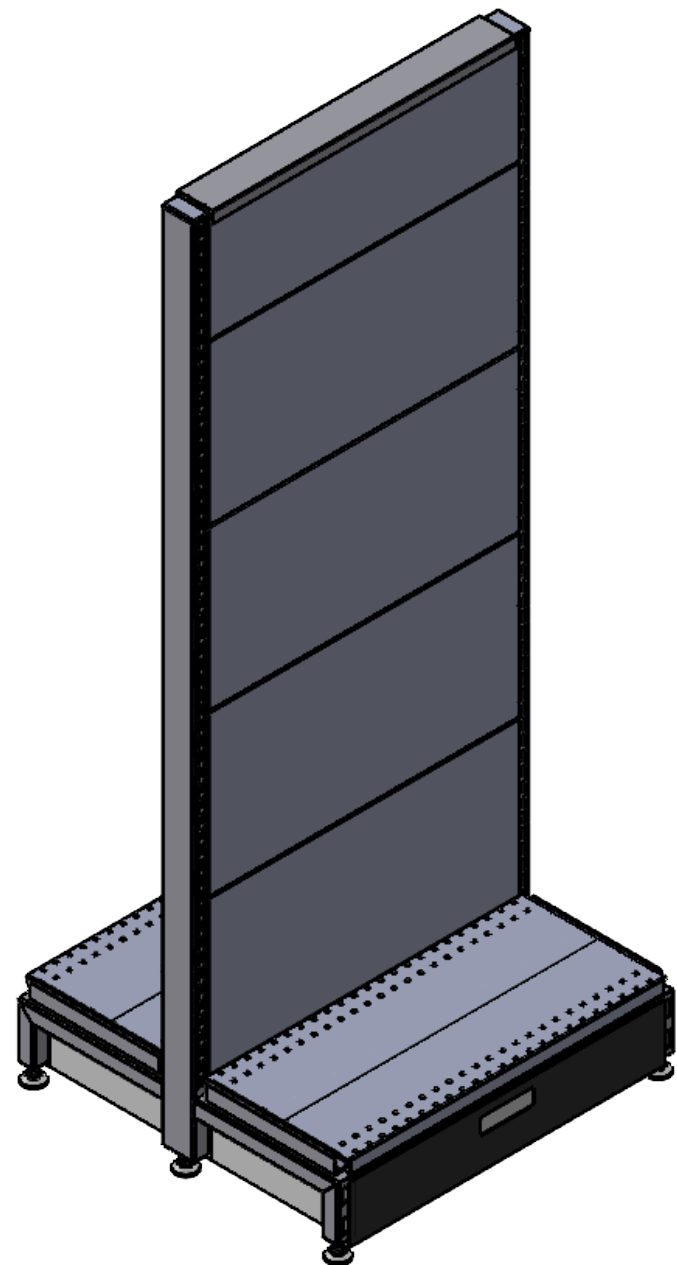

Rev	Date	Description

ALL DIMENSIONS IN (mm)
UNLESS OTHERWISE SPECIFIED
BREAK ALL SHARP EDGES

TOLERANCES
(BEFORE PAINTING
& AFTER PLATING)
X ± 1.00
X.X ± 0.50
X.XX ± 0.10
ANGLES ± 0.5°

A02- CLIENT
CLIENT: RFA1000
PROJ. NO.: TBA
PART NO.: --
Revision --
Page 2

600mm(W)x1515mm(H)x270mm(D)
DOUBLE SIDED GONDOLA BAY-NON PERFORATED
SLIMLINE - ADD BAY (PEARL WHITE)

PRODUCT CODE: **RFA1047**
Date: 13/06/2023
Drawn by DH
Checked by --

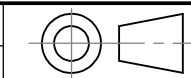
DO NOT SCALE
Scale@A3 1:15

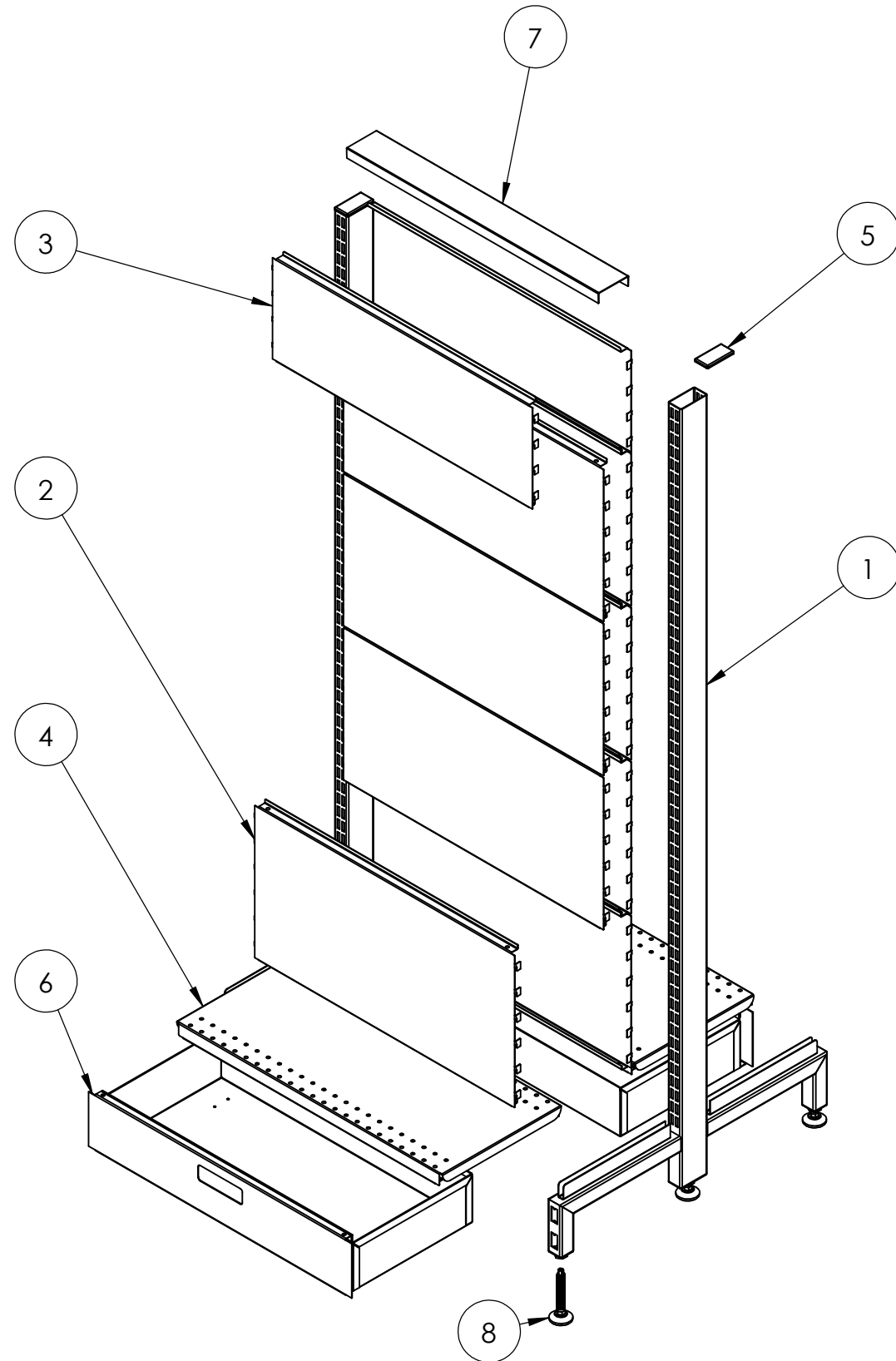

ITEM NO.	DESCRIPTION	QTY.
1	POST - DOUBLE SIDED GONDOLA - 1515 MM (H) - W/. 270 MM LEGS - PEARL WHITE	1
2	CLIP IN PANEL - 600 MM (W) X 300 MM (H) - NON PERFORATED - PEARL WHITE	8
3	CLIP IN PANEL - 600 MM (W) X 200 MM (H) - NON PERFORATED - PEARL WHITE	2
4	SHELF STEEL - 600 MM (W) X 270 MM (D) - PEARL WHITE	2
5	PLASTIC ENDCAP	2
6	SKIRT DRAWER BOX - 600mm	2
7	600 MM (W) SLIMLINE INTERNAL TOP CAP CLIPPER - FOR DDS	1
8	M12 LEVELING FEET	6

Rev	Date	Description

ALL DIMENSIONS IN (mm)
UNLESS OTHERWISE SPECIFIED
BREAK ALL SHARP EDGES

TOLERANCES
(BEFORE PAINTING
& AFTER PLATING)
X ± 1.00
X.X ± 0.50
X.XX ± 0.10
ANGLES ± 0.5°

A09- EXPLODED
CLIENT: RFA1000
PROJ. NO.: TBA
PART NO.: --
Revision --
Page 9

600mm(W)x1515mm(H)x270mm(D)
DOUBLE SIDED GONDOLA BAY-NON PERFORATED
SLIMLINE - ADD BAY (PEARL WHITE)

PRODUCT CODE: **RFA1047**

Date: 13/06/2023

Drawn by DH

Checked by --

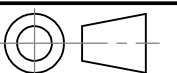

DO NOT SCALE

Scale@A3 1:20