

This product is an Add Bay  
 \* Supplied with (1) post only  
 \* Connects to the post of the neighboring Bay

Rev	Date	Description

ALL DIMENSIONS IN (mm)  
 UNLESS OTHERWISE SPECIFIED  
 BREAK ALL SHARP EDGES

TOLERANCES  
 (BEFORE PAINTING  
 & AFTER PLATING)  
 X ± 1.00  
 X.X ± 0.50  
 X.XX ± 0.10  
 ANGLES ± 0.5°

A01- RENDER  
 CLIENT: RFA1000  
 PROJ. NO.: TBA  
 PART NO.: --  
 Revision --  
 Page 1

600mm(W)x1515mm(H)x270mm(D)  
 DOUBLE SIDED GONDOLA BAY-NON PERFORATED  
 SLIMLINE - ADDBAY (PEARL WHITE)

PRODUCT CODE: <b>RFA1045</b>	
Date: 13/06/2023	
Drawn by DH	DO NOT SCALE
Checked by --	Scale@A3 1:20

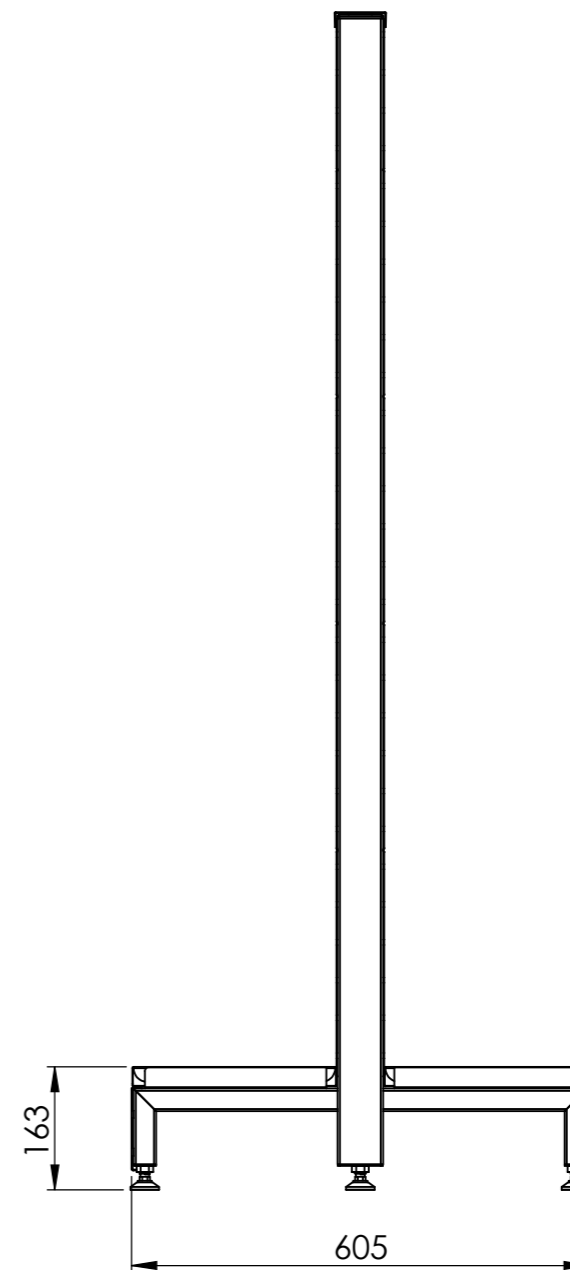
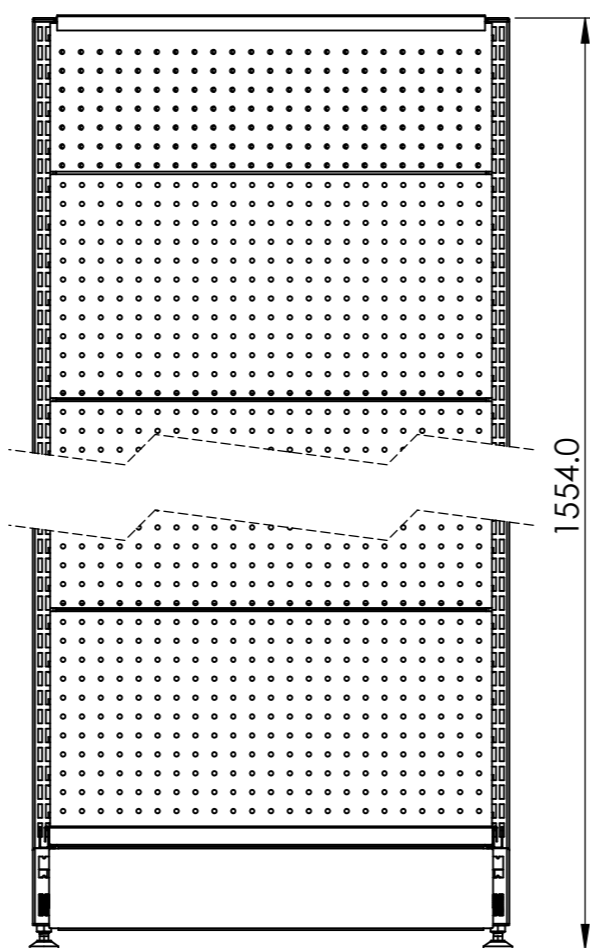
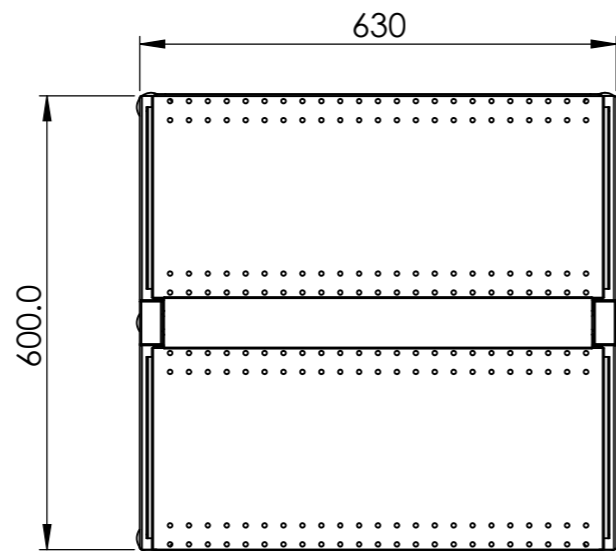
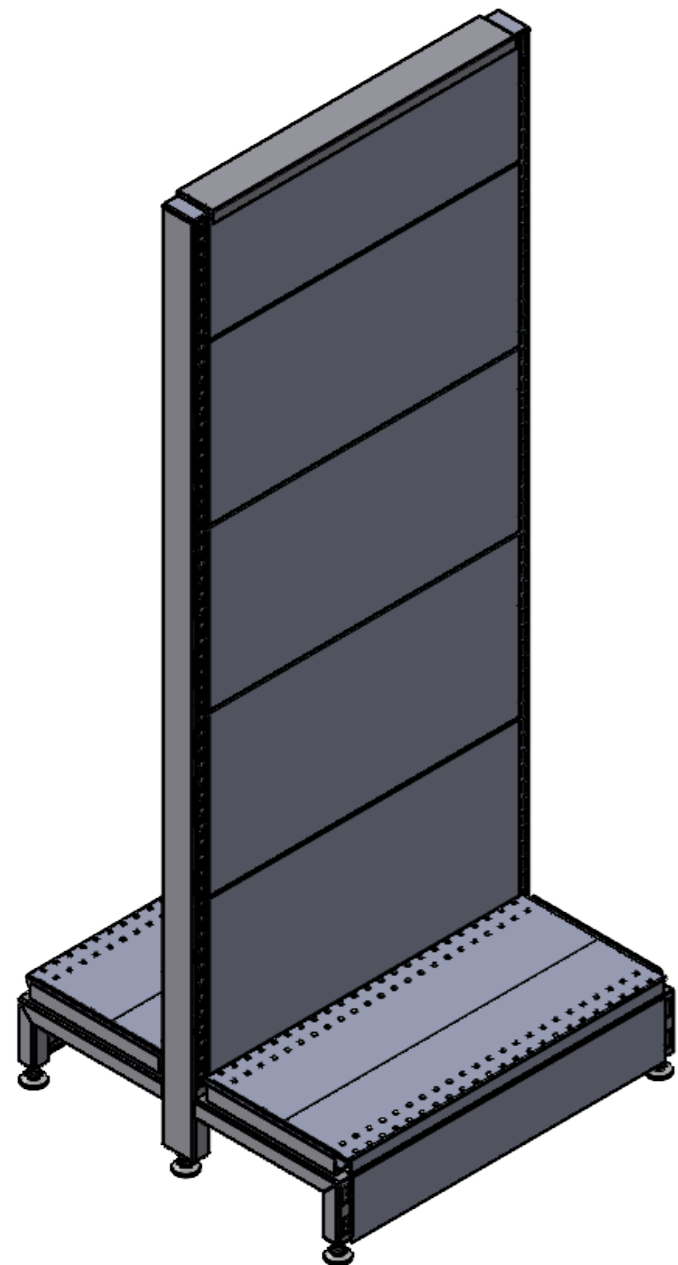

Rev	Date	Description

ALL DIMENSIONS IN (mm)  
UNLESS OTHERWISE SPECIFIED  
BREAK ALL SHARP EDGES

TOLERANCES  
(BEFORE PAINTING  
& AFTER PLATING)  
X ± 1.00  
X.X ± 0.50  
X.XX ± 0.10  
ANGLES ± 0.5°

A02- CLIENT  
CLIENT: RFA1000  
PROJ. NO.: TBA  
PART NO.: --  
Revision --  
Page 2

600mm(W)x1515mm(H)x270mm(D)  
DOUBLE SIDED GONDOLA BAY-NON PERFORATED  
SLIMLINE - ADDBAY (PEARL WHITE)

PRODUCT CODE: **RFA1045**

Date: 13/06/2023

Drawn by DH

Checked by --

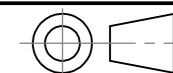

DO NOT SCALE

Scale@A3 1:15

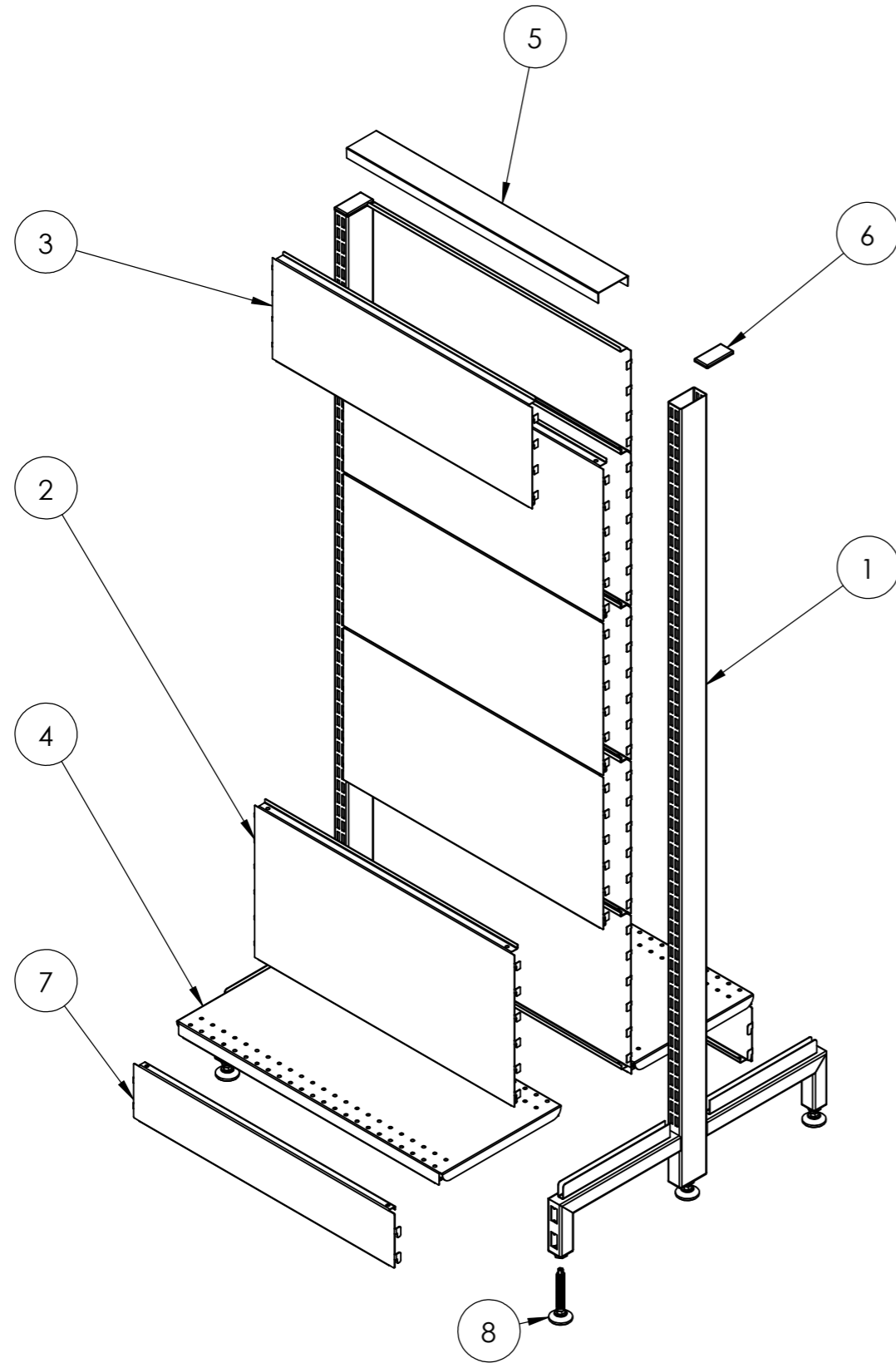

ITEM NO.	DESCRIPTION	QTY.
1	POST - DOUBLE SIDED GONDOLA - 1515 MM (H) - W/. 270 MM LEGS - PEARL WHITE	1
2	CLIP IN PANEL - 600 MM (W) X 300 MM (H) - NON PERFORATED - PEARL WHITE	8
3	CLIP IN PANEL - 600 MM (W) X 200 MM (H) - NON PERFORATED - PEARL WHITE	2
4	SHELF STEEL - 600 MM (W) X 270 MM (D) - PEARL WHITE	2
5	600 MM (W) SLIMLINE INTERNAL TOP CAP CLIPPER - FOR DDS	1
6	PLASTIC ENDCAP	2
7	BOTTOM SKIRT	2
8	M12 LEVELING FEET	6

Rev	Date	Description

ALL DIMENSIONS IN (mm)  
UNLESS OTHERWISE SPECIFIED  
BREAK ALL SHARP EDGES

TOLERANCES  
(BEFORE PAINTING  
& AFTER PLATING)  
X ± 1.00  
X.X ± 0.50  
X.XX ± 0.10  
ANGLES ± 0.5°

A09- EXPLODED  
CLIENT: RFA1000  
PROJ. NO.: TBA  
PART NO.: --  
Revision --  
Page 9

600mm(W)x1515mm(H)x270mm(D)  
DOUBLE SIDED GONDOLA BAY-NON PERFORATED  
SLIMLINE - ADD BAY (PEARL WHITE)

PRODUCT CODE: **RFA1045**

Date: 13/06/2023

Drawn by DH

Checked by --

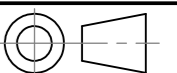

DO NOT SCALE

Scale@A3 1:20