



ASSOCIATED PROJECTS

COMMERCIAL BUILDERS,
PROJECT MANAGERS,
PLANNERS & DESIGNERS

T 03 8787 3000 F 03 8787 3025
48-58 Cyber Loop, Dandenong South VIC 3175

Rev	Date	Description

ALL DIMENSIONS IN (mm)
UNLESS OTHERWISE SPECIFIED
BREAK ALL SHARP EDGES

TOLERANCES
(BEFORE PAINTING
& AFTER PLATING)
X ± 1.00
X.X ± 0.50
X.XX ± 0.10
ANGLES ± 0.5°

A01- RENDER
CLIENT: RFA1000
PROJ. NO.: TBA
PART NO.: --
Revision --
Page 1

600mm(W)x1515mm(H)x270mm(D)		
DOUBLE SIDED GONDOLA BAY-PERFORATED SLIMLINE- START BAY (PEARL WHITE)		
PRODUCT CODE: RFA1036		DO NOT SCALE Scale@A3 1:20
Date:	13/06/2023	
Drawn by	DH	
Checked by	--	

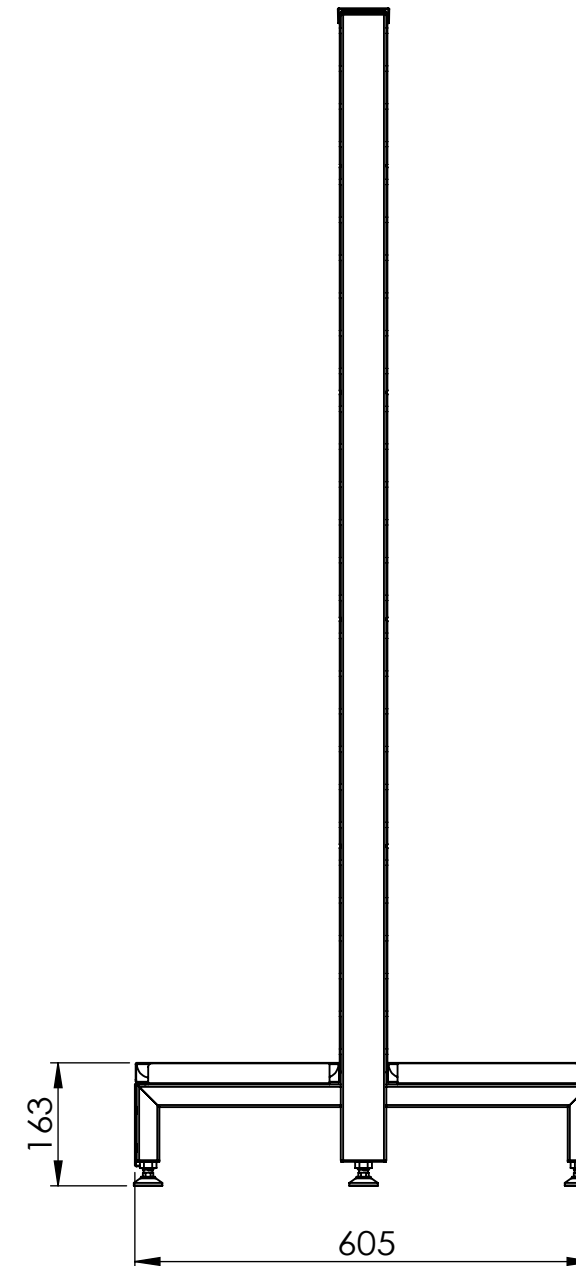
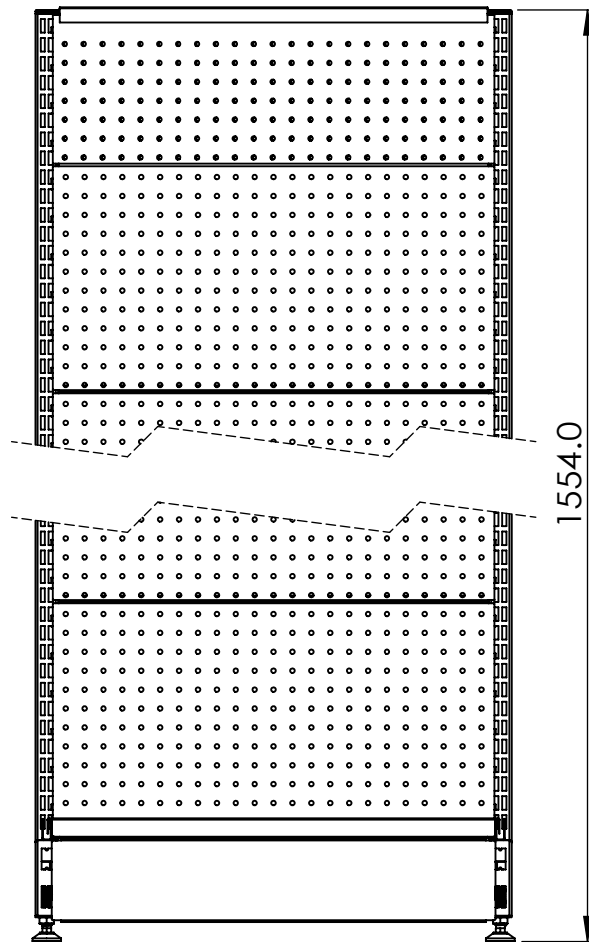
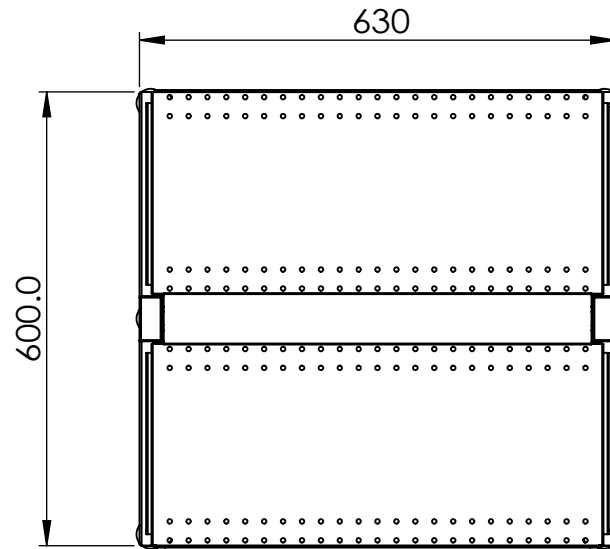
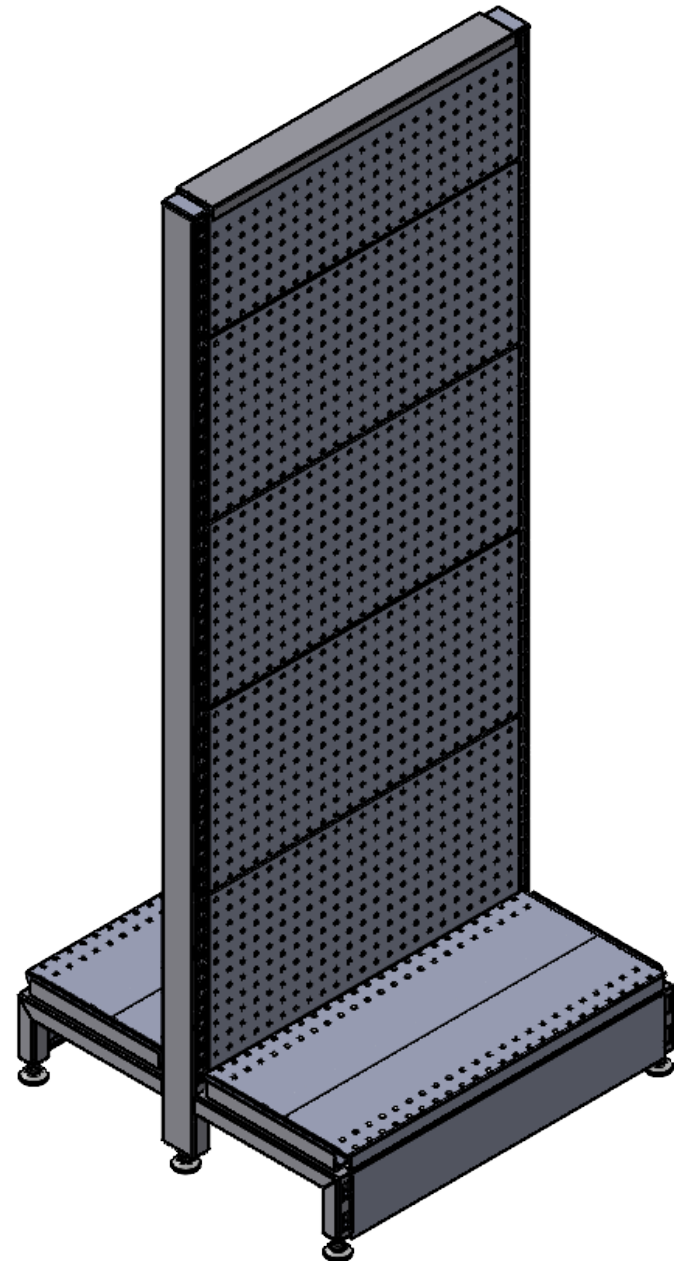

Rev	Date	Description

ALL DIMENSIONS IN (mm)
UNLESS OTHERWISE SPECIFIED
BREAK ALL SHARP EDGES

TOLERANCES
(BEFORE PAINTING
& AFTER PLATING)
X ± 1.00
X.X ± 0.50
X.XX ± 0.10
ANGLES ± 0.5°

A02- CLIENT

CLIENT: RFA1000

PROJ. NO.: TBA

PART NO.: --

Revision --

Page 2

600mm(W)x1515mm(H)x270mm(D)
DOUBLE SIDED GONDOLA BAY-PERFORATED
SLIMLINE - START BAY (PEARL WHITE)

PRODUCT CODE: **RFA1036**

Date: 13/06/2023

Drawn by DH

Checked by --

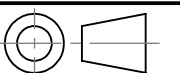

DO NOT SCALE

Scale@A3 1:15

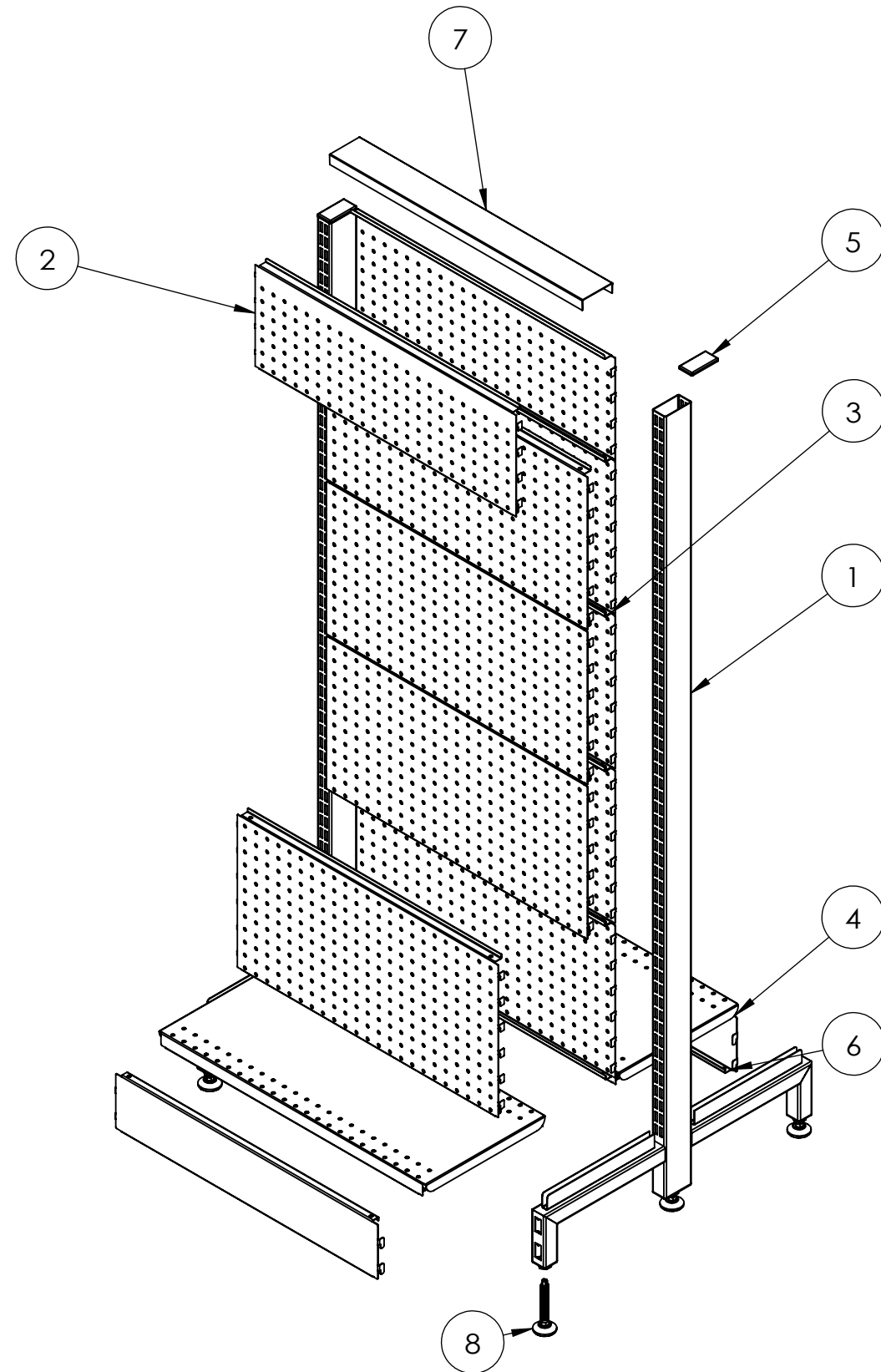

ITEM NO.	DESCRIPTION	QTY.
1	POST - DOUBLE SIDED GONDOLA - 1515 MM (H) - W/. 270 MM LEGS - PEARL WHITE	2
2	CLIP IN PANEL - 600 MM (W) X 200 MM (H) - NON PERFORATED - PEARL WHITE	2
3	CLIP IN PANEL - 600 MM (W) X 300 MM (H) - NON PERFORATED - PEARL WHITE	8
4	SHELF STEEL - 600 MM (W) X 270 MM (D) - PEARL WHITE	2
5	PLASTIC ENDCAP	2
6	BOTTOM SKIRT	2
7	600 MM (W) SLIMLINE INTERNAL TOP CAP CLIPPER - FOR DDS	1
8	M12 LEVELING FEET	6

Rev	Date	Description

ALL DIMENSIONS IN (mm)
UNLESS OTHERWISE SPECIFIED
BREAK ALL SHARP EDGES

TOLERANCES
(BEFORE PAINTING
& AFTER PLATING)
X ± 1.00
X.X ± 0.50
X.XX ± 0.10
ANGLES ± 0.5°

A09- EXPLODED

CLIENT: RFA1000

PROJ. NO.: TBA

PART NO.: --

Revision --

Page 9

600mm(W)x1515mm(H)x270mm(D)
DOUBLE SIDED GONDOLA BAY-PERFORATED
SLIMLINE - START BAY (PEARL WHITE)

PRODUCT CODE: **RFA1036**

Date: 13/06/2023

Drawn by DH

Checked by --

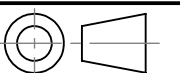

DO NOT SCALE

Scale@A3 1:20