

This product is an Add Bay
 * Supplied with (1) post only
 * Connects to the post of the neighboring Bay.

Rev	Date	Description

ALL DIMENSIONS IN (mm)
 UNLESS OTHERWISE SPECIFIED
 BREAK ALL SHARP EDGES

TOLERANCES
 (BEFORE PAINTING
 & AFTER PLATING)
 X ± 1.00
 X.X ± 0.50
 X.XX ± 0.10
 ANGLES ± 0.5°

A01- RENDER
 CLIENT: RFA1000
 PROJ. NO.: TBA
 PART NO.: --
 Revision --
 Page 1

600 X 1515 DOUBLE SIDED GONDOLA BAY -
 NON PERFORATED

PRODUCT CODE: RFA1035	
Date: 9/06/2023	
Drawn by DH	DO NOT SCALE
Checked by --	Scale@A3 1:20

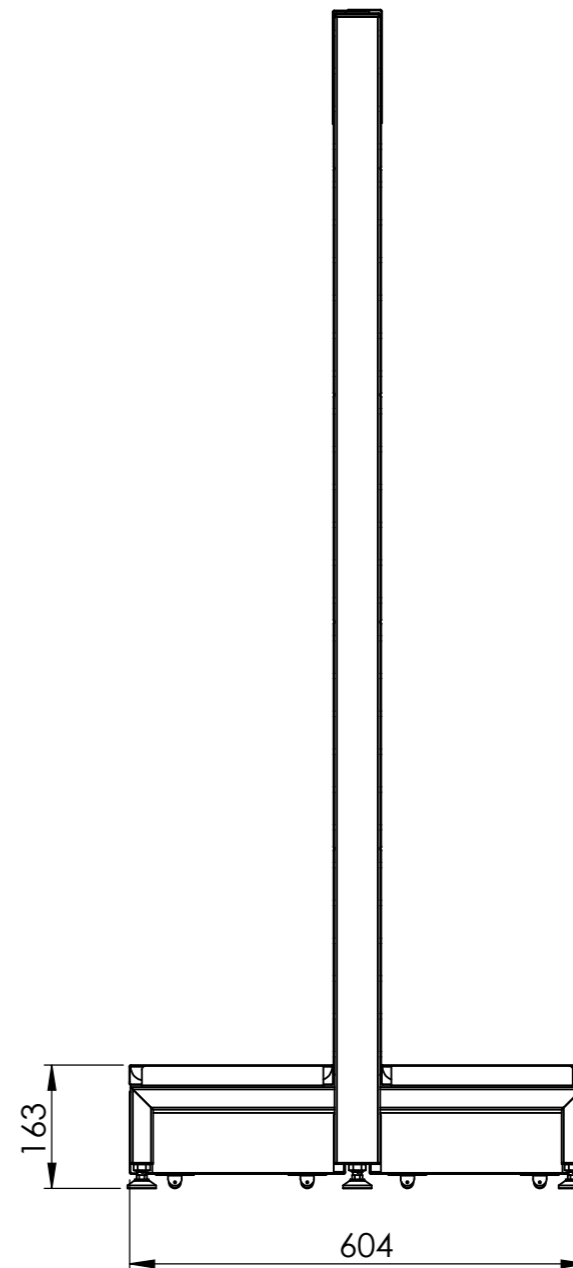
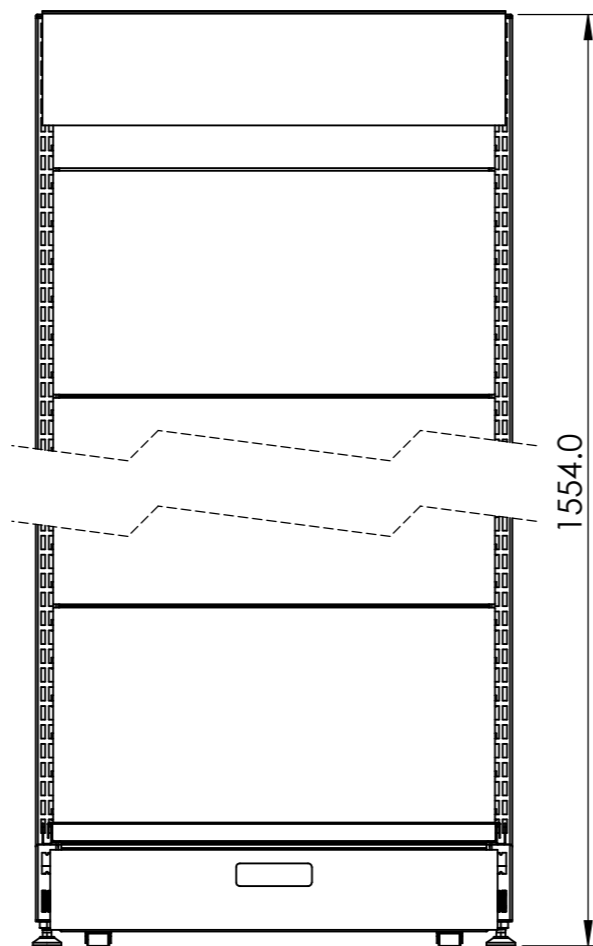
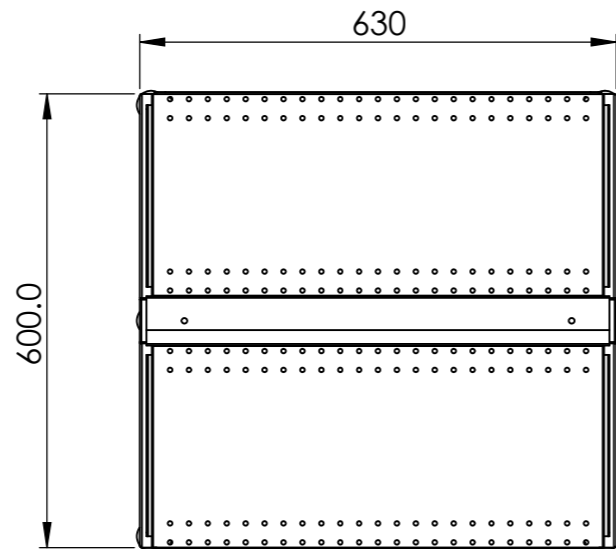
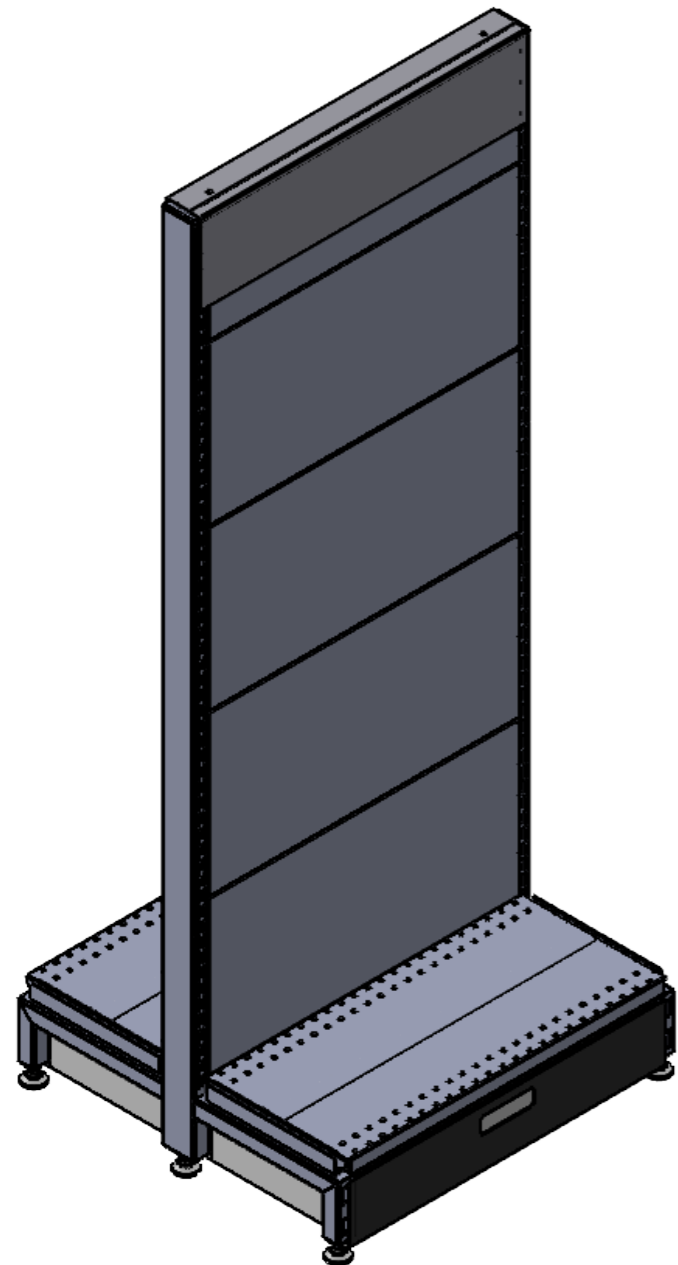

Rev	Date	Description

ALL DIMENSIONS IN (mm)
UNLESS OTHERWISE SPECIFIED
BREAK ALL SHARP EDGES

TOLERANCES
(BEFORE PAINTING
& AFTER PLATING)
X ± 1.00
X.X ± 0.50
X.XX ± 0.10
ANGLES ± 0.5°

A02- CLIENT
CLIENT: RFA1000
PROJ. NO.: TBA
PART NO.: --
Revision --
Page 2

600 X 1515 DOUBLE SIDED GONDOLA BAY -
NON PERFORATED

PRODUCT CODE: **RFA1035**

Date: 9/06/2023

Drawn by DH

Checked by --

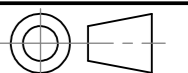

DO NOT SCALE

Scale@A3 1:15

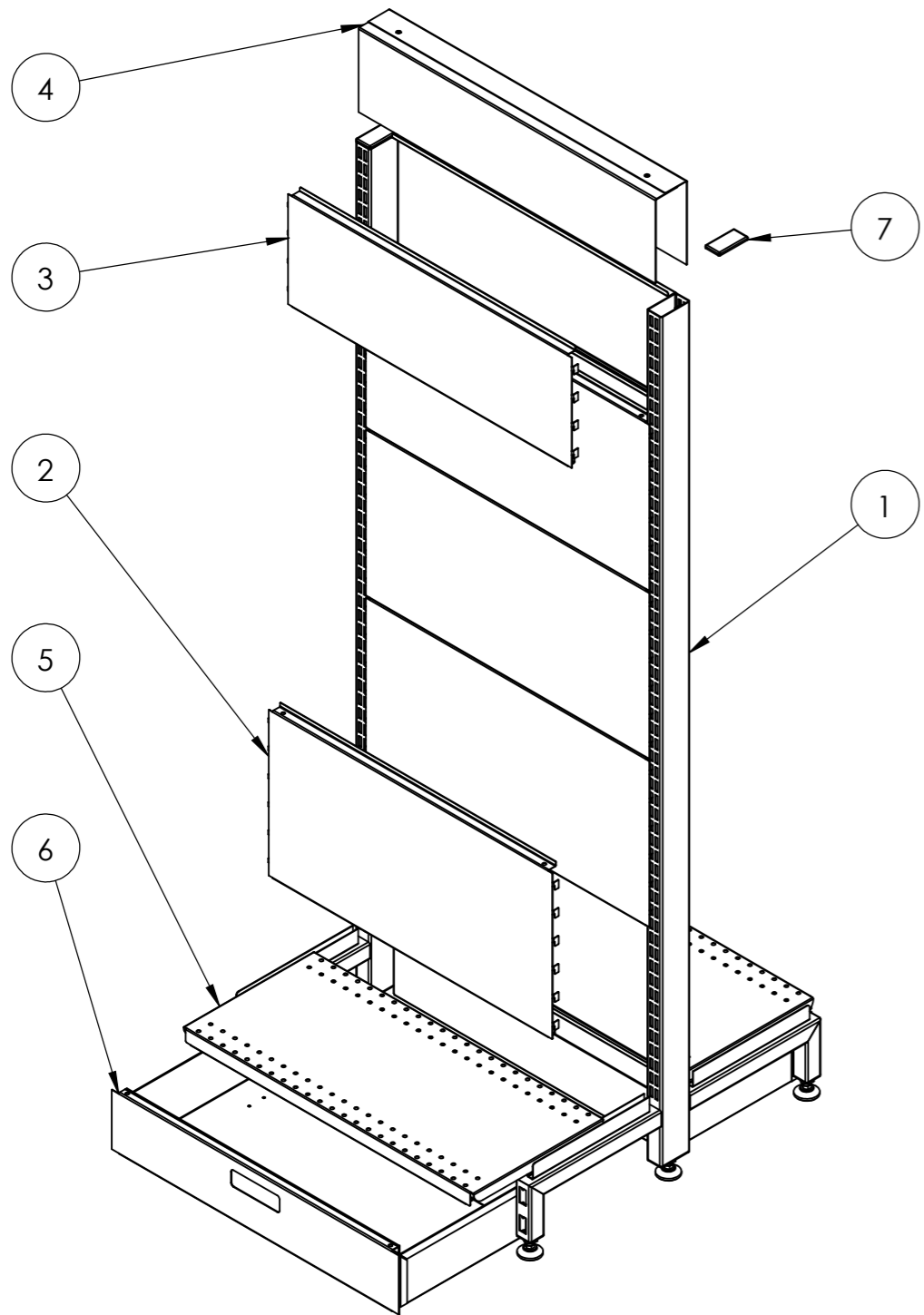

ITEM NO.	DESCRIPTION	QTY.
1	POST - DOUBLE SIDED GONDOLA - 1515 MM (H) - W/. 270 MM LEGS - PEARL WHITE	1
2	CLIP IN PANEL - 600 MM (W) X 300 MM (H) - PERFORATED - PEARL WHITE	8
3	CLIP IN PANEL - 600 MM (W) X 200 MM (H) - PERFORATED - PEARL WHITE	2
4	TOP CAP - 600 MM (W) X 150 MM (H) - PEARL WHITE - FOR TWCM	1
5	SHELF STEEL - 600 MM (W) X 270 MM (D) - PEARL WHITE	2
6	SKIRT DRAWER BOX - 600mm	2
7	PLASTIC ENDCAP	2
8	M12 LEVELING FEET	6
9	BOTTOM SKIRT	1

This Add Bay is only supplied with one post as it attaches to an existing post on a Start Bay.

Rev	Date	Description

ALL DIMENSIONS IN (mm)
 UNLESS OTHERWISE SPECIFIED
 BREAK ALL SHARP EDGES

TOLERANCES
 (BEFORE PAINTING
 & AFTER PLATING)
 X ± 1.00
 X.X ± 0.50
 X.XX ± 0.10
 ANGLES ± 0.5°

A09- EXPLODED VIEW
 CLIENT: RFA1000
 PROJ. NO.: TBA
 PART NO.: --
 Revision --
 Page 9

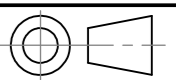
600 X 1515 DOUBLE SIDED GONDOLA BAY - NON PERFORATED		
PRODUCT CODE: RFA1035	Date: 9/06/2023	
Drawn by: DH	Checked by: --	DO NOT SCALE
		Scale@A3 1:20