

Rev	Date	Description

ALL DIMENSIONS IN (mm)
UNLESS OTHERWISE SPECIFIED
BREAK ALL SHARP EDGES

TOLERANCES
(BEFORE PAINTING
& AFTER PLATING)
X ± 1.00
X.X ± 0.50
X.XX ± 0.10
ANGLES ± 0.5°

A01- RENDER
CLIENT: RFA1000
PROJ. NO.: TBA
PART NO.: --
Revision --
Page 1

900mm(W)x1515mm(H)x270mm(D)		
DOUBLE SIDED GONDOLA BAY-PERFORATED START BAY (PEARL WHITE)		
PRODUCT CODE: RFA1030		DO NOT SCALE
Date:	19/06/2023	
Drawn by	DH	
Checked by	--	
		Scale@A3 1:20

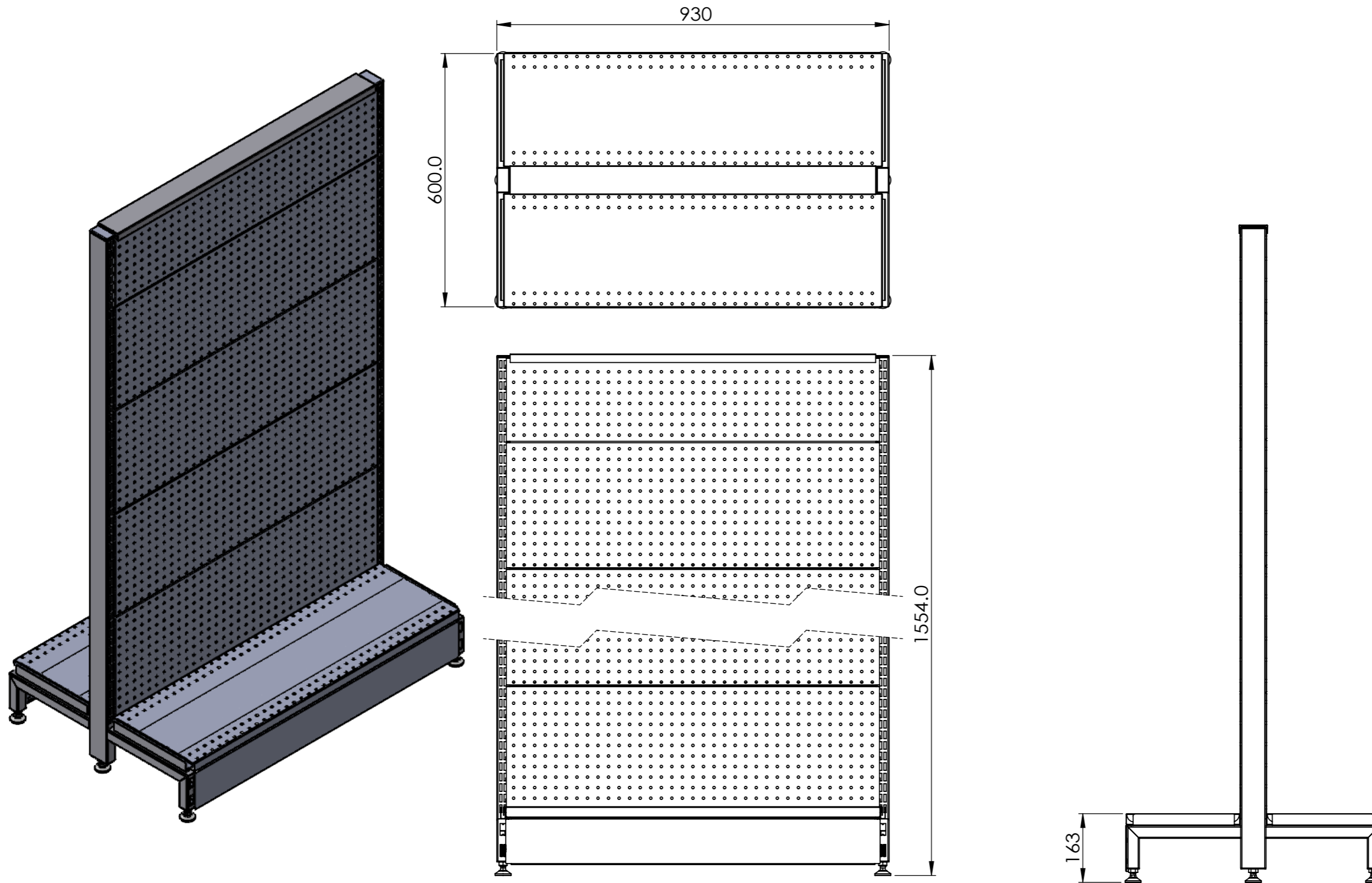

Rev	Date	Description

ALL DIMENSIONS IN (mm)
UNLESS OTHERWISE SPECIFIED
BREAK ALL SHARP EDGES

TOLERANCES
(BEFORE PAINTING
& AFTER PLATING)
X ± 1.00
X.X ± 0.50
X.XX ± 0.10
ANGLES ± 0.5°

A02- CLIENT
CLIENT: RFA1000
PROJ. NO.: TBA
PART NO.: --
Revision --
Page 2

900mm(W)x1515mm(H)x270mm(D)
DOUBLE SIDED GONDOLA BAY-PERFORATED
- START BAY (PEARL WHITE)

PRODUCT CODE: **RFA1030**

Date: 19/06/2023

Drawn by DH

Checked by --

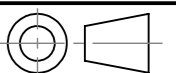

DO NOT SCALE

Scale@A3 1:15

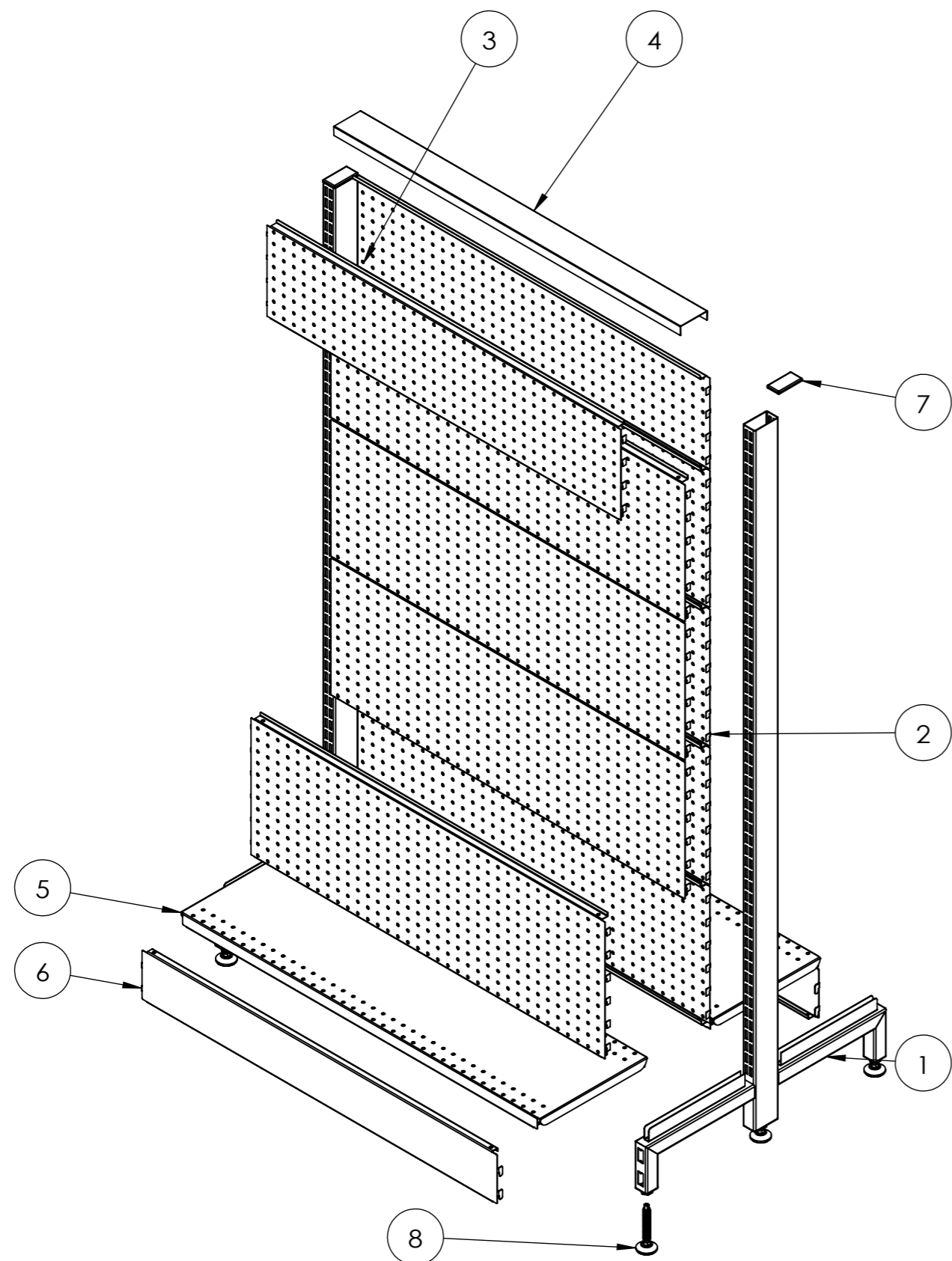

ITEM NO.	DESCRIPTION	QTY.
1	POST - DOUBLE SIDED GONDOLA - 1515 MM (H) - W/. 270 MM LEGS - PEARL WHITE	2
2	CLIP IN PANEL - 900(W) X 300 H) - PERFORATED - PEARL WHITE	8
3	CLIP IN PANEL - 900 MM (W) X 200 MM (H) - PERFORATED - PEARL WHITE	2
4	900 MM (W) SLIMLINE INTERNAL TOP CAP CLIPPER - FOR DDS	1
5	SHELF STEEL - 900 MM (W) X 270 MM (D) - PEARL WHITE	2
6	900 BOTTOM SKIRT	2
7	PLASTIC ENDCAP	2
8	M12 LEVELING FEET	6

Rev	Date	Description

ALL DIMENSIONS IN (mm)
UNLESS OTHERWISE SPECIFIED
BREAK ALL SHARP EDGES

TOLERANCES
(BEFORE PAINTING
& AFTER PLATING)
X ± 1.00
X.X ± 0.50
X.XX ± 0.10
ANGLES ± 0.5°

A09- EXPLODED
CLIENT: RFA1000
PROJ. NO.: TBA
PART NO.: --
Revision --
Page 9

900mm(W)x1515mm(H)x270mm(D)
DOUBLE SIDED GONDOLA BAY-PERFORATED
- START BAY (PEARL WHITE)

PRODUCT CODE: **RFA1030**

Date: 19/06/2023

Drawn by DH

Checked by --

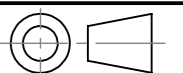

DO NOT SCALE

Scale@A3 1:20