



This product is an Add Bay

*Supplied with (1) post only
 *Add Bay connects to the post of the neighboring Bay

FINISH: P/C PEARL WHITE

AP ASSOCIATED PROJECTS COMMERCIAL BUILDERS,
 PROJECT MANAGERS,
 PLANNERS & DESIGNERS

T 03 8787 3000 F 03 8787 3025
 48-58 Cyber Loop, Dandenong South VIC 3175

Rev	Date	Description

ALL DIMENSIONS IN (mm)
 UNLESS OTHERWISE SPECIFIED
 BREAK ALL SHARP EDGES

TOLERANCES
 (BEFORE PAINTING
 & AFTER PLATING)
 X ± 1.00
 X.X ± 0.50
 X.XX ± 0.10
 ANGLES ± 0.5°

A01- RENDER
CLIENT: RFA1000
PROJ. NO.: TBA
PART NO.: --
Revision --
Page 1

ADD BAY-DOUBLE SIDED GONDOLA-NON PERF.
W900 x H1515 x D270

PRODUCT CODE: RFA1029

Date: 4/07/2024

Drawn by DH

Checked by --

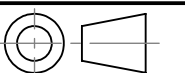

DO NOT SCALE

Scale@A3 1:20

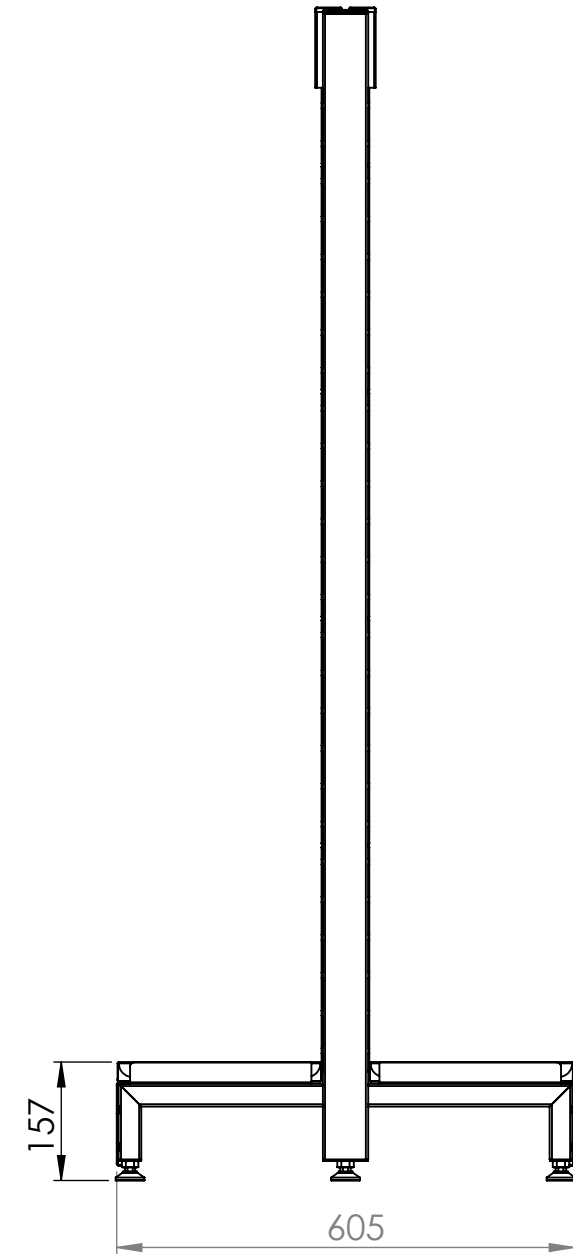
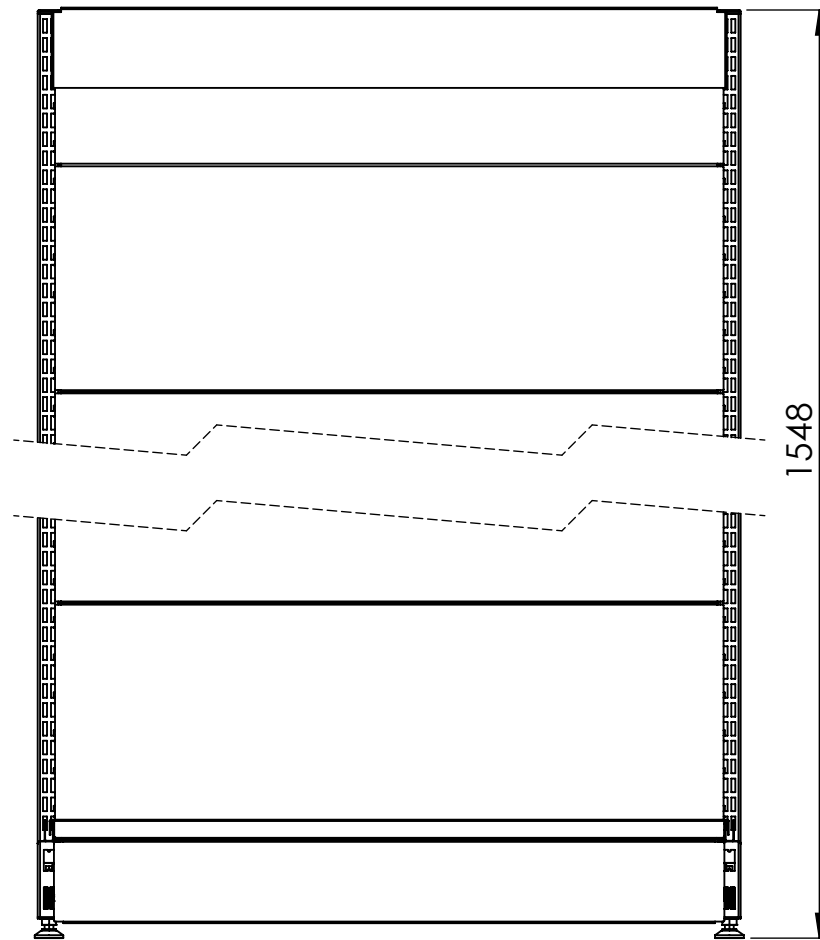
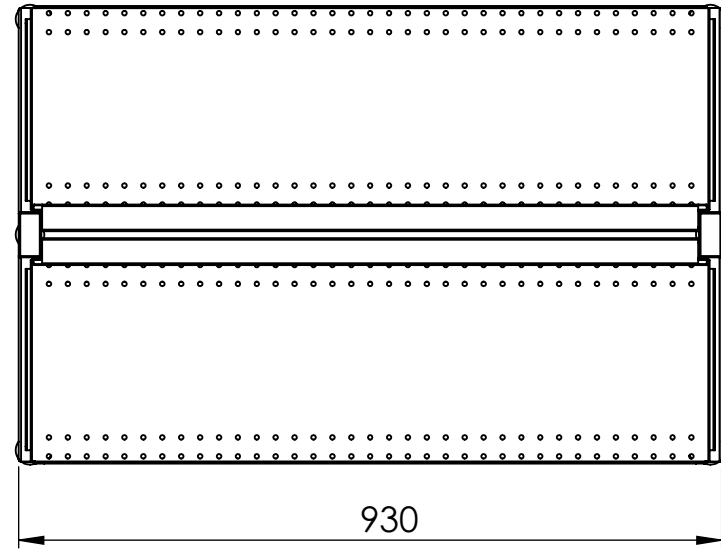
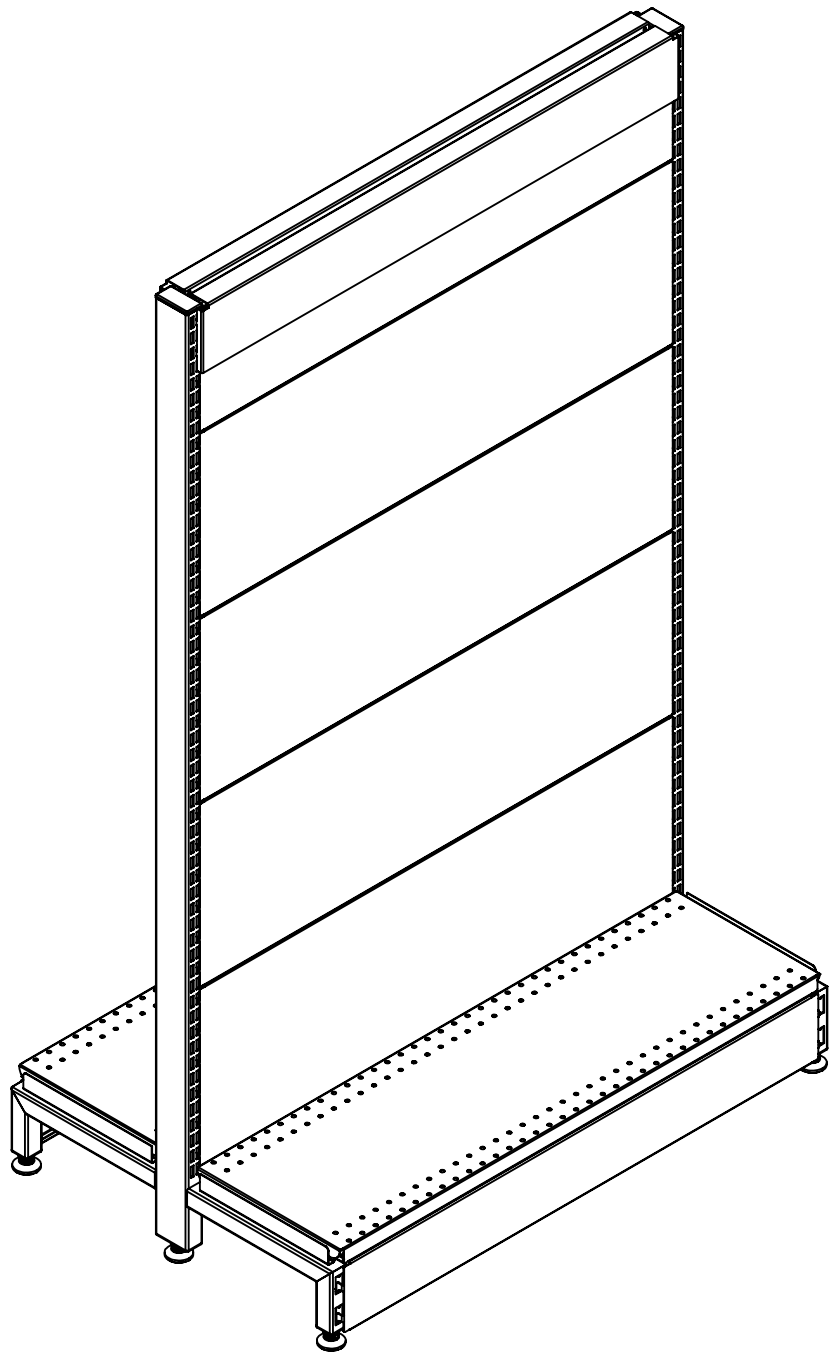

Rev	Date	Description

ALL DIMENSIONS IN (mm)
UNLESS OTHERWISE SPECIFIED
BREAK ALL SHARP EDGES

TOLERANCES
(BEFORE PAINTING
& AFTER PLATING)
X ± 1.00
X.X ± 0.50
X.XX ± 0.10
ANGLES ± 0.5°

A02- MECHANICAL

CLIENT: RFA1000

PROJ. NO.: TBA

PART NO.: --

Revision --

Page 2

START BAY-DOUBLE SIDED GONDOLA-NON PERF.
W900 x H1515 x D270

PRODUCT CODE: **RFA1028**

Date: 4/07/2024

Drawn by DH

Checked by --

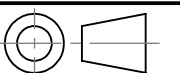

DO NOT SCALE

Scale@A3 1:15

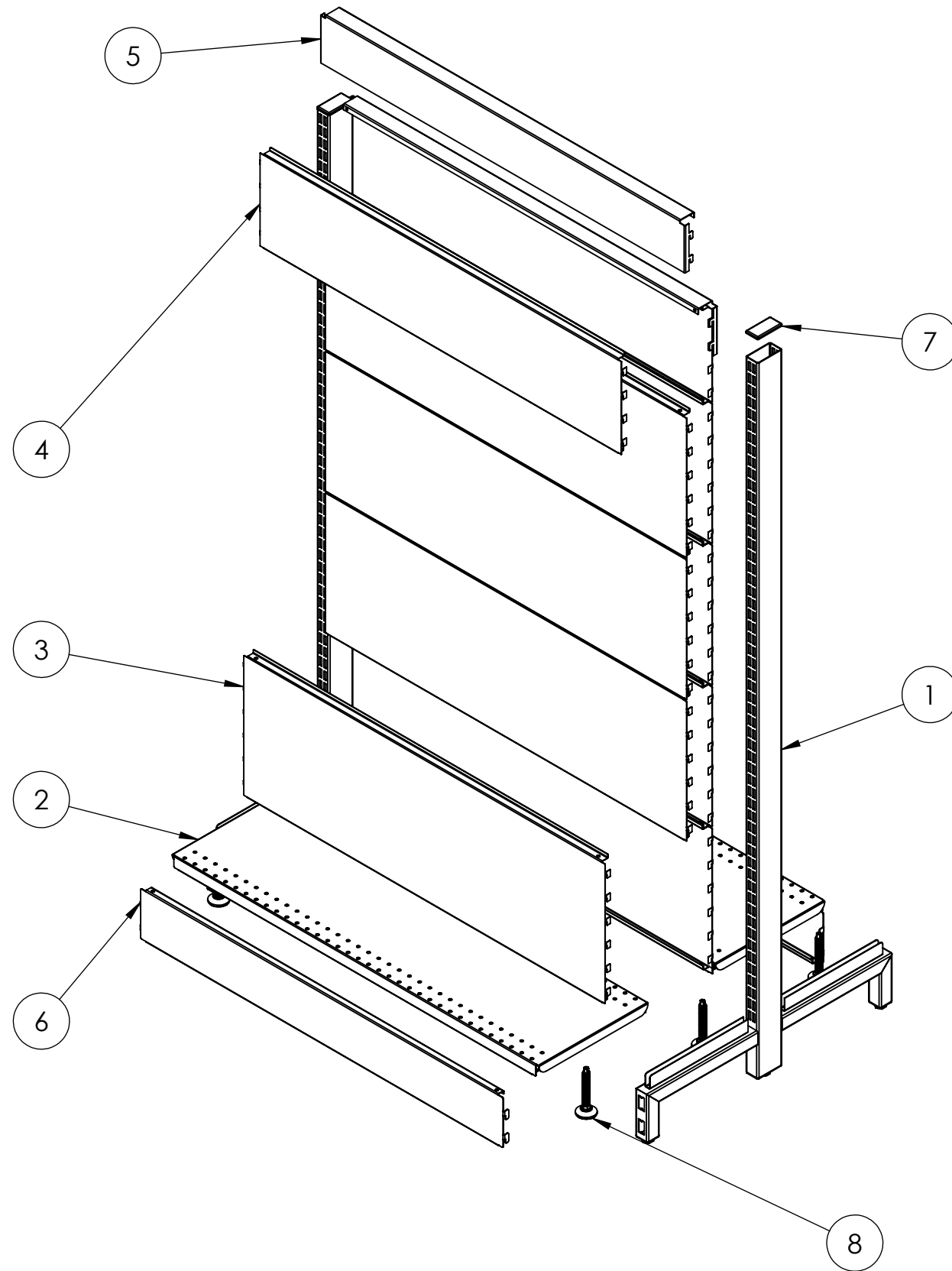

ITEM NO.	DESCRIPTION	QTY.
1	POST - DOUBLE SIDED GONDOLA - 1515 MM (H) - W/. 270 MM LEGS - PEARL WHITE	2
2	SHELF STEEL - 900 MM (W) X 270 MM (D) - PEARL WHITE	2
3	CLIP IN PANEL - 900(W) X 300(H) - NON PERFORATED - PEARL WHITE	8
4	CLIP IN PANEL - 900 MM (W) X 200 MM (H) - NON PERFORATED - PEARL WHITE	2
5	SNAP IN TOP CAP	2
6	900 BOTTOM SKIRT	2
7	PLASTIC ENDCAP	2
8	M12 LEVELING FEET	6

Rev	Date	Description

ALL DIMENSIONS IN (mm)
UNLESS OTHERWISE SPECIFIED
BREAK ALL SHARP EDGES

TOLERANCES
(BEFORE PAINTING
& AFTER PLATING)
X ± 1.00
X.X ± 0.50
X.XX ± 0.10
ANGLES ± 0.5°

A09- EXPLODED

CLIENT: RFA1000

PROJ. NO.: TBA

PART NO.: --

Revision --

Page 9

ADD BAY-DOUBLE SIDED GONDOLA-NON PERF.
W900 x H1515 x D270

PRODUCT CODE: **RFA1029**

Date: 4/07/2024

Drawn by DH

Checked by --

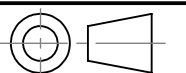

DO NOT SCALE

Scale@A3 1:20