

ASSOCIATED PROJECTS

COMMERCIAL BUILDERS,
PROJECT MANAGERS,
PLANNERS & DESIGNERS

T 03 8787 3000 F 03 8787 3025
48-58 Cyber Loop, Dandenong South VIC 3175

Rev	Date	Description

ALL DIMENSIONS IN (mm)
UNLESS OTHERWISE SPECIFIED
BREAK ALL SHARP EDGES

TOLERANCES
(BEFORE PAINTING
& AFTER PLATING)
X ± 1.00
X.X ± 0.50
X.XX ± 0.10
ANGLES ± 0.5°

A01- RENDER
CLIENT: RFA1000
PROJ. NO.: TBA
PART NO.: --
Revision --
Page 1

600mm(W)x1515mm(H)x270mm(D)		
DOUBLE SIDED GONDOLA BAY- NON PERFORATED		
START BAY WITH SKIRT DRAWER (PEARL WHITE)		DO NOT SCALE Scale@A3 1:20
PRODUCT CODE: RFA1026		
Date: 6/06/2023		
Drawn by: DH		
Checked by: --		

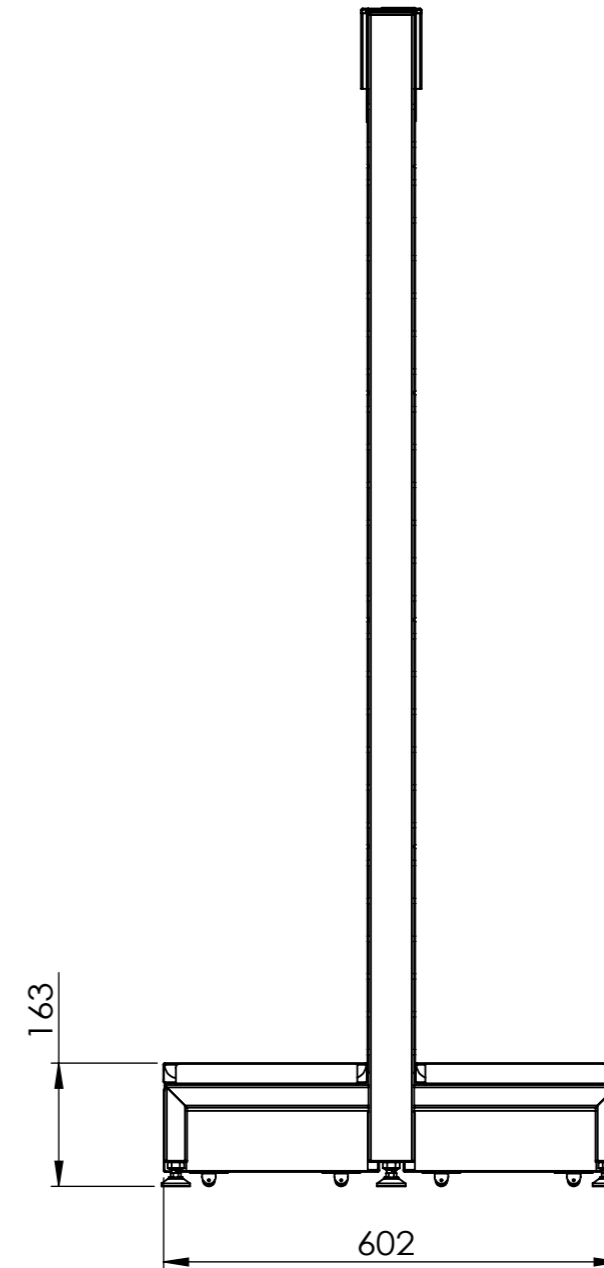
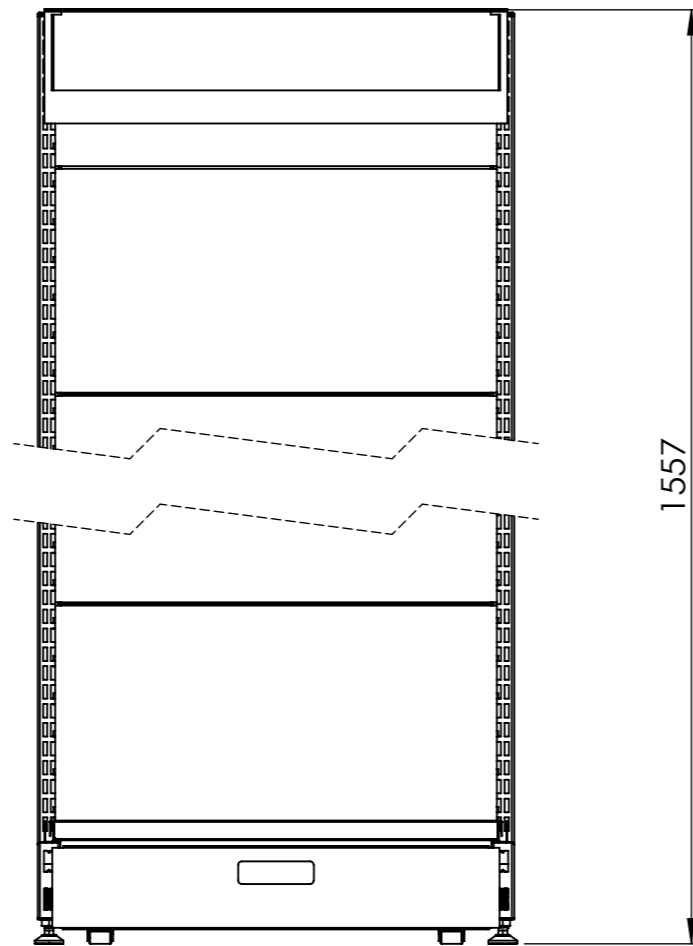
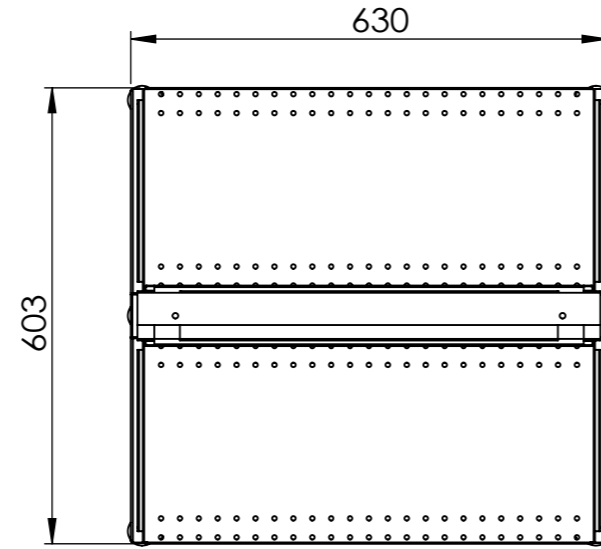
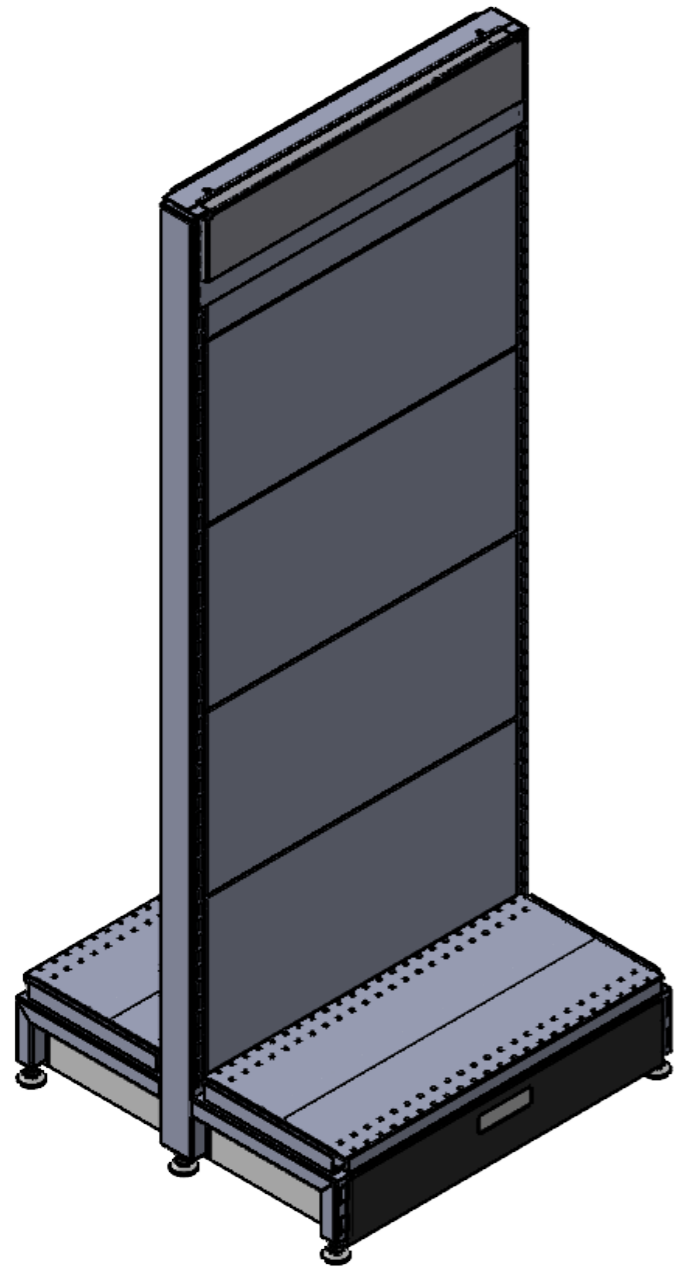

Rev	Date	Description

ALL DIMENSIONS IN (mm)
UNLESS OTHERWISE SPECIFIED
BREAK ALL SHARP EDGES

TOLERANCES
(BEFORE PAINTING
& AFTER PLATING)
X ± 1.00
X.X ± 0.50
X.XX ± 0.10
ANGLES ± 0.5°

A02- CLIENT
CLIENT: RFA1000
PROJ. NO.: TBA
PART NO.: --
Revision --
Page 2

600mm(W)x1515mm(H)x270mm(D)
DOUBLE SIDED GONDOLA BAY- PERFORATED
START BAY (PEARL WHITE)

PRODUCT CODE: **RFA1026**

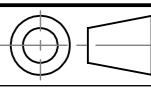
Date:	6/06/2023	 DO NOT SCALE
Drawn by	DH	
Checked by	--	

Scale@A3 1:15

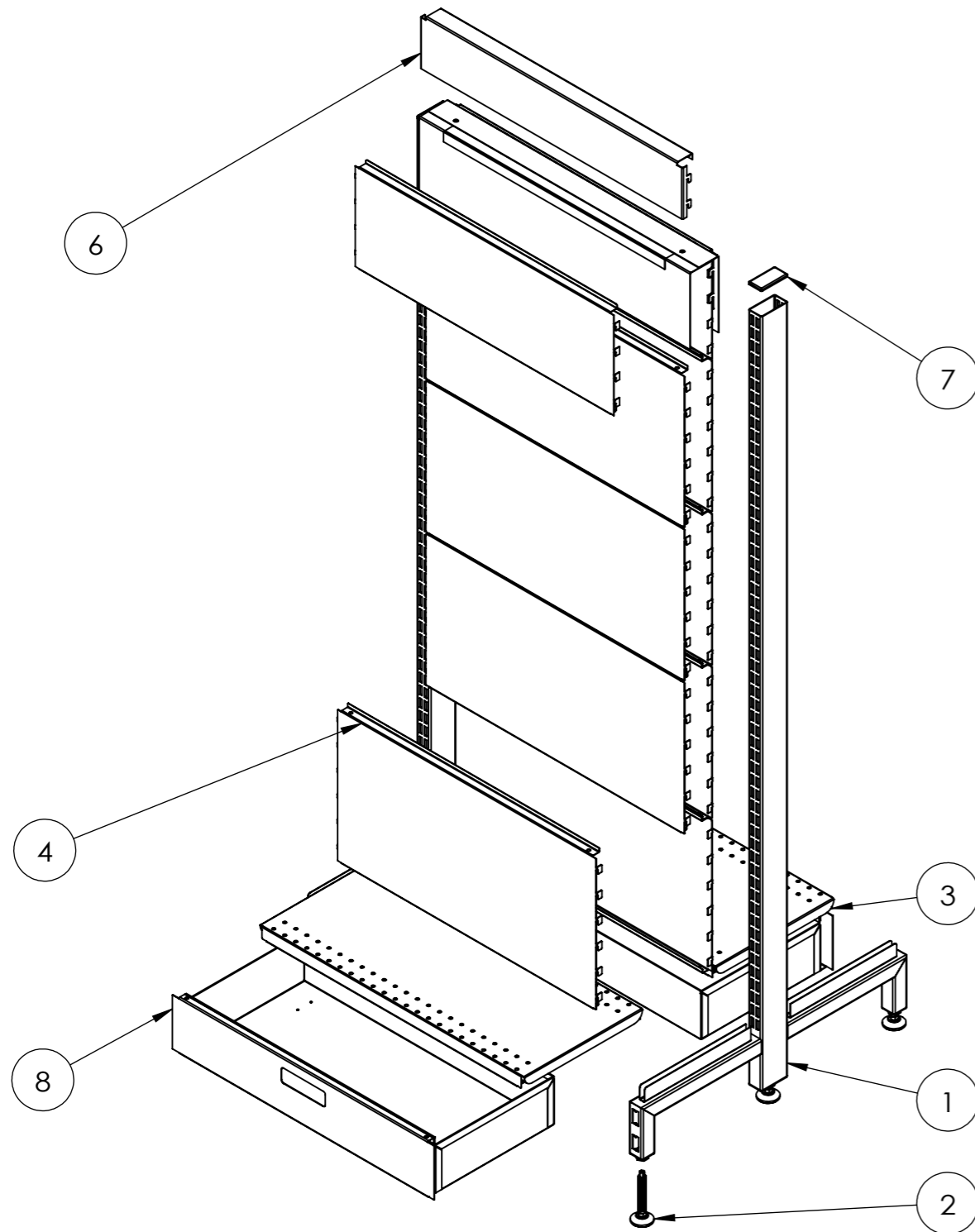

ITEM NO.	DESCRIPTION	QTY.
1	DOUBLE SIDED POST	2
2	M12 LEVELING FEET	6
3	600X270 SHELF	2
4	600W x 300H PERF PANEL	8
5	600W X 200H PERF. PANEL	2
6	SNAP IN TOP CAP	2
7	PLASTIC ENDCAP	2
8	SKIRT DRAWER ASSY.	2
9		1
10		1

Rev	Date	Description

ALL DIMENSIONS IN (mm)
UNLESS OTHERWISE SPECIFIED
BREAK ALL SHARP EDGES

TOLERANCES
(BEFORE PAINTING
& AFTER PLATING)
X ± 1.00
X.X ± 0.50
X.XX ± 0.10
ANGLES ± 0.5°

A09- EXPLODED
CLIENT: RFA1000
PROJ. NO.: TBA
PART NO.: --
Revision --
Page 9

600mm(W)x1515mm(H)x270mm(D)
DOUBLE SIDED GONDOLA BAY- PERFORATED
START BAY (PEARL WHITE)

PRODUCT CODE: **RFA1026**

Date: 6/06/2023

Drawn by DH

Checked by --

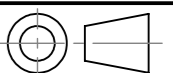

DO NOT SCALE

Scale@A3 1:20