



This product is an Add Bay
 * Supplied with (1) post only
 * Connects to the post of the neighboring Bay

Rev	Date	Description

ALL DIMENSIONS IN (mm)
 UNLESS OTHERWISE SPECIFIED
 BREAK ALL SHARP EDGES

TOLERANCES
 (BEFORE PAINTING
 & AFTER PLATING)
 X ± 1.00
 X.X ± 0.50
 X.XX ± 0.10
 ANGLES ± 0.5°

A01- RENDER
 CLIENT: RFA1000
 PROJ. NO.: TBA
 PART NO.: --
 Revision --
 Page 1

600mm(W)x1515mm(H)x270mm(D) DOUBLE SIDED GONDOLA BAY-NON PERFORATED ADD BAY (PEARL WHITE)	
PRODUCT CODE: RFA1025	
Date: 28/10/2022	DO NOT SCALE
Drawn by DH	Scale@A3 1:20
Checked by --	

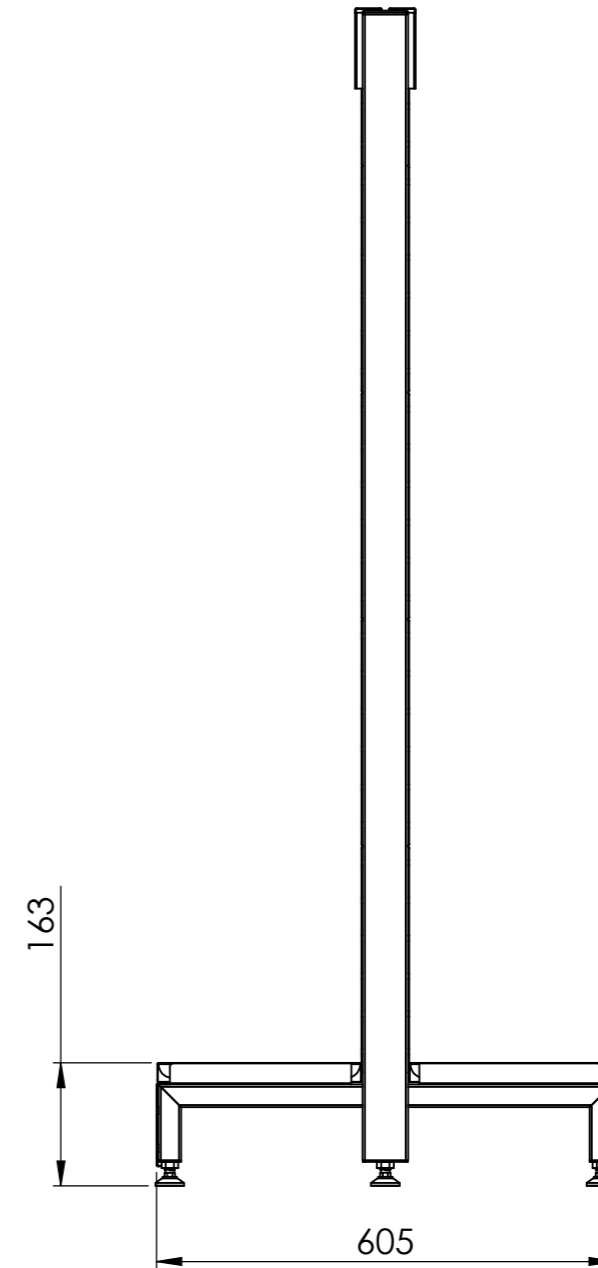
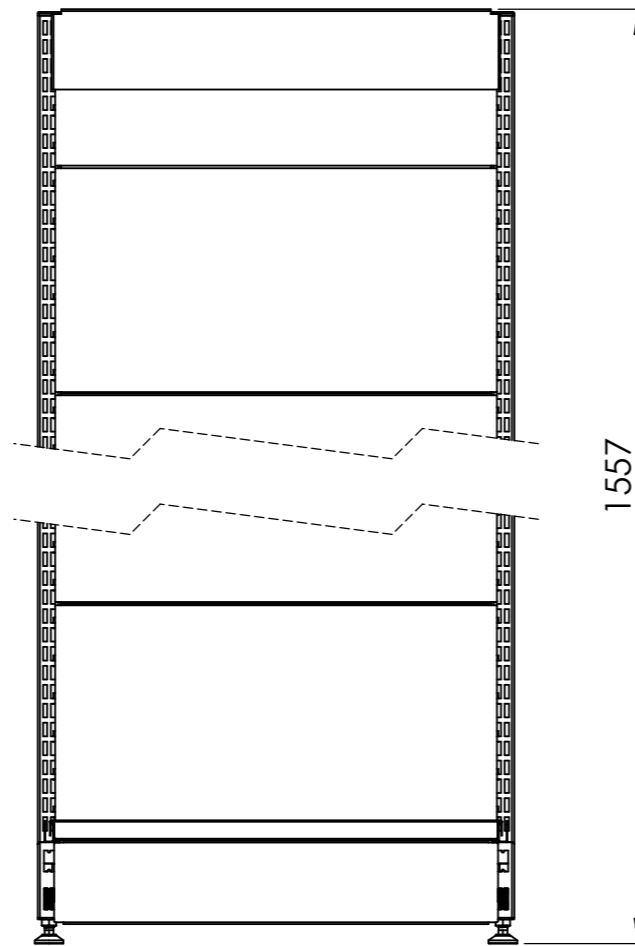
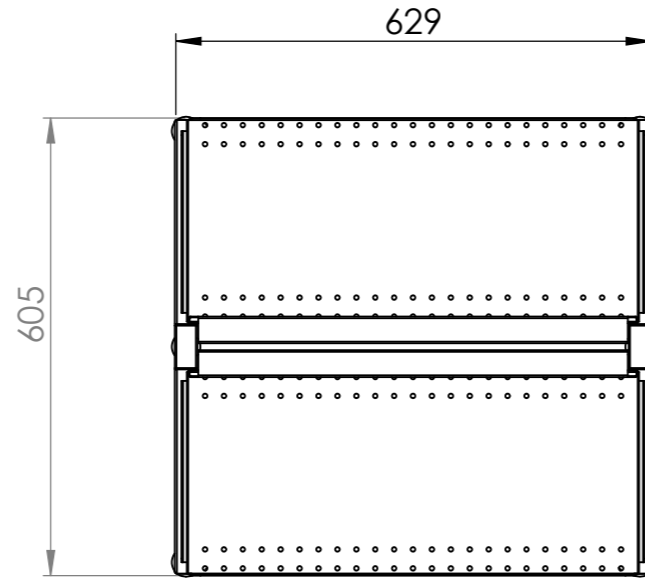
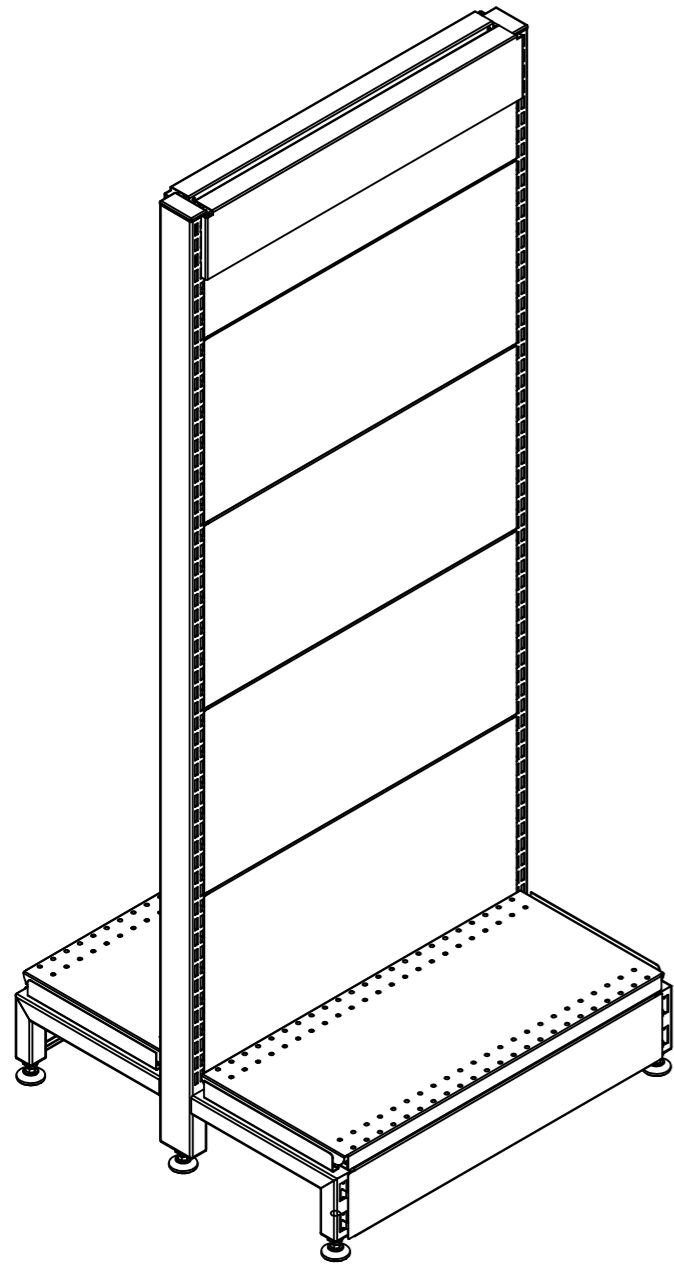

Rev	Date	Description

ALL DIMENSIONS IN (mm)
UNLESS OTHERWISE SPECIFIED
BREAK ALL SHARP EDGES

TOLERANCES
(BEFORE PAINTING
& AFTER PLATING)
X ± 1.00
X.X ± 0.50
X.XX ± 0.10
ANGLES ± 0.5°

A02- CLIENT
CLIENT: RFA1000
PROJ. NO.: TBA
PART NO.: --
Revision --
Page 2

600mm(W)x1515mm(H)x270mm(D)
DOUBLE SIDED GONDOLA BAY-NON
PERFORATED ADD BAY (PEARL WHITE)

PRODUCT CODE: **RFA1025**
Date: 28/10/2022
Drawn by DH
Checked by --

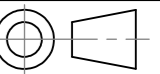
DO NOT SCALE
Scale@A3 1:15

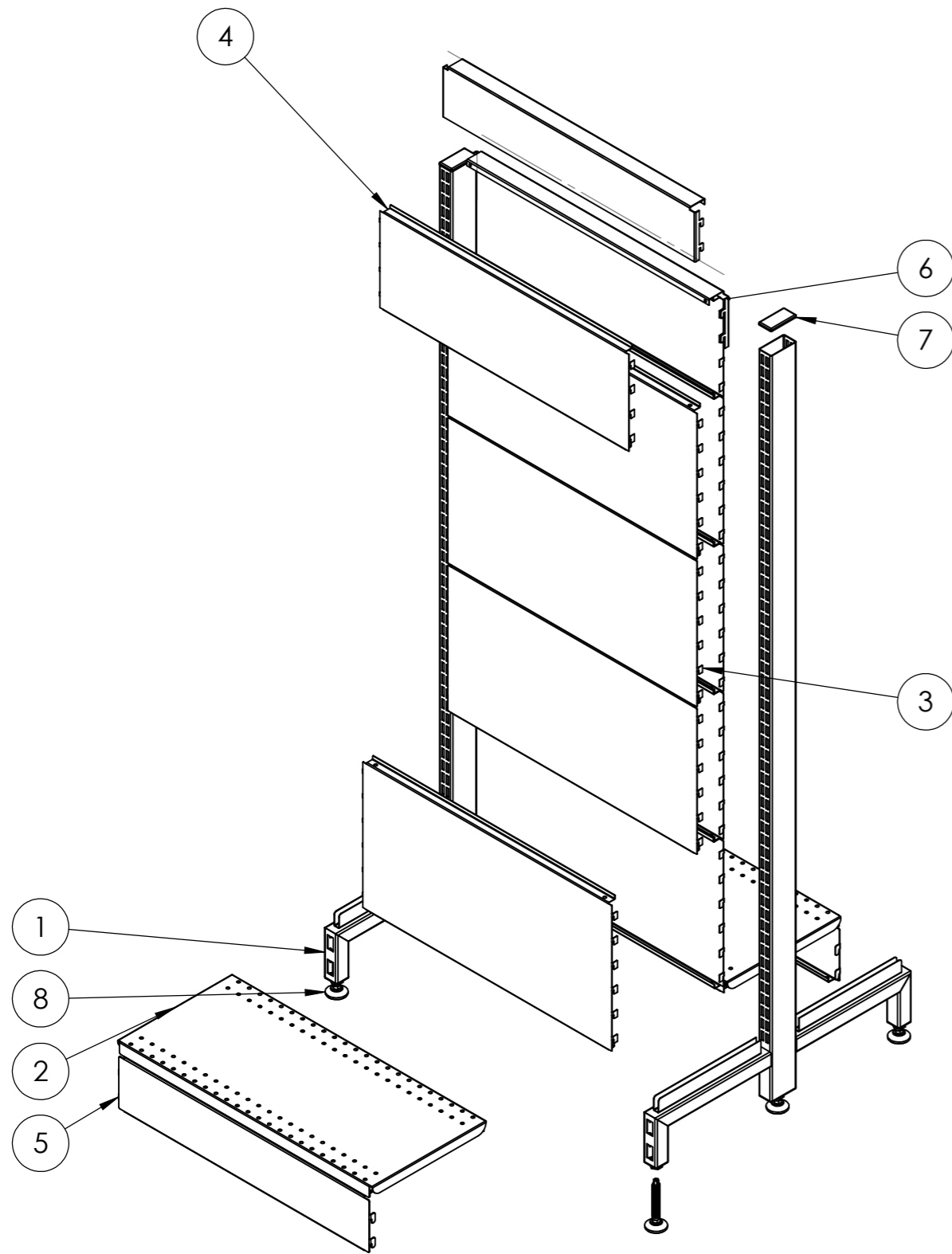

ITEM NO.	DESCRIPTION	QTY.
1	DOUBLE SIDED POST	1
2	600X270 SHELF	2
3	600W x 300H PERF PANEL	4
4	600W X 200H PERF. PANEL	1
5	BOTTOM SKIRT	2
6	SNAP IN TOP CAP	2
7	PLASTIC ENDCAP	2
8	ADJ. FEET	6

This Add Bay is only supplied with one post as it attaches to an existing post on a Start Bay.

Rev	Date	Description

