

AP ASSOCIATED PROJECTS COMMERCIAL BUILDERS,
PROJECT MANAGERS,
PLANNERS & DESIGNERS

T 03 8787 3000 F 03 8787 3025
48-58 Cyber Loop, Dandenong South VIC 3175

Rev	Date	Description

ALL DIMENSIONS IN (mm)
UNLESS OTHERWISE SPECIFIED
BREAK ALL SHARP EDGES

TOLERANCES
(BEFORE PAINTING
& AFTER PLATING)
X ± 1.00
X.X ± 0.50
X.XX ± 0.10
ANGLES ± 0.5°

A01- RENDER
CLIENT: RFA1000
PROJ. NO.: TBA
PART NO.: --
Revision --
Page 1

**RFA1016 600(W) X 1515 (H) DOUBLE
SIDED GONDOLA BAY-PERFORATED
- START BAY**

PRODUCT CODE: RFA1016	
Date: 26/10/2022	
Drawn by DH	DO NOT SCALE
Checked by --	Scale@A3 1:20

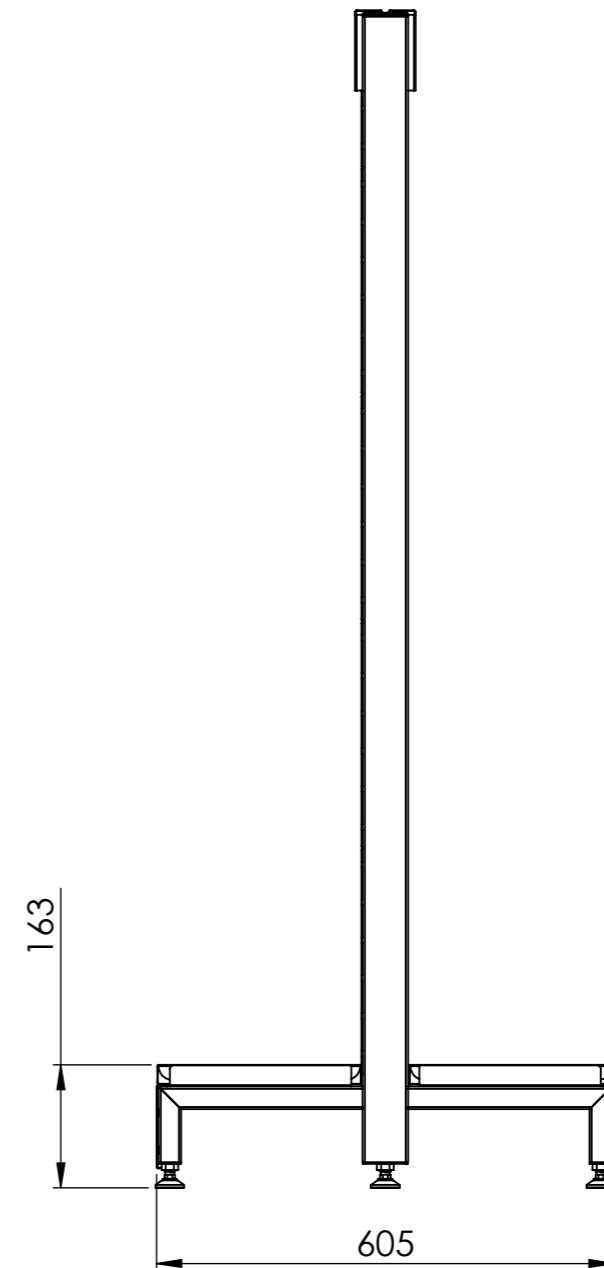
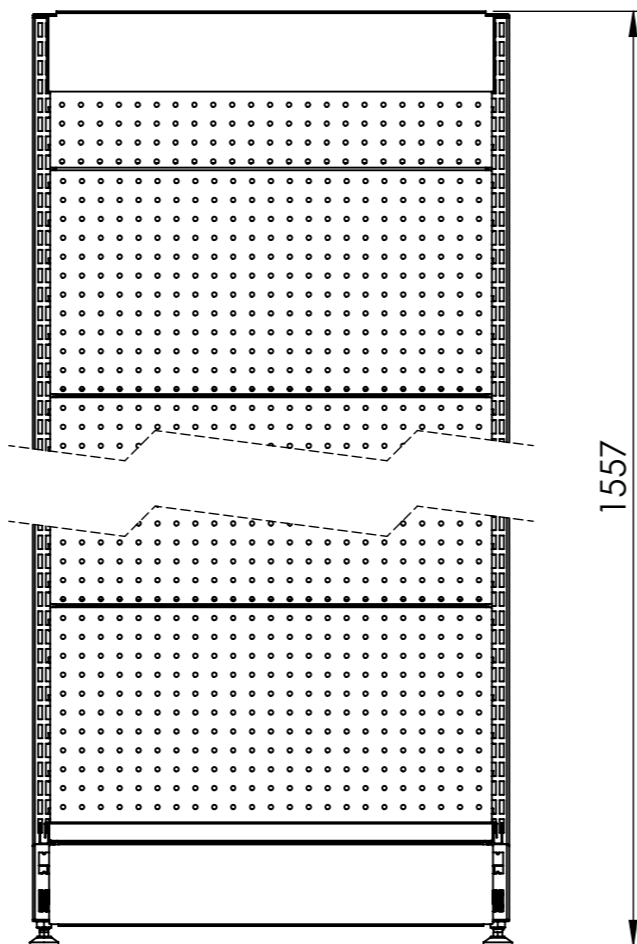
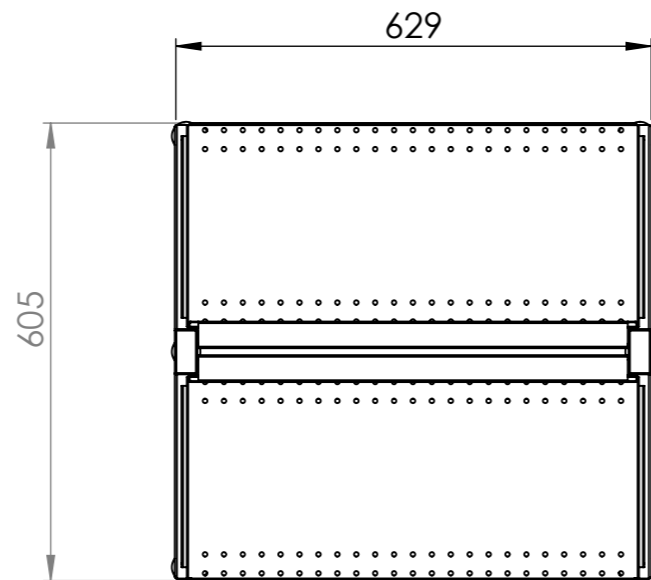
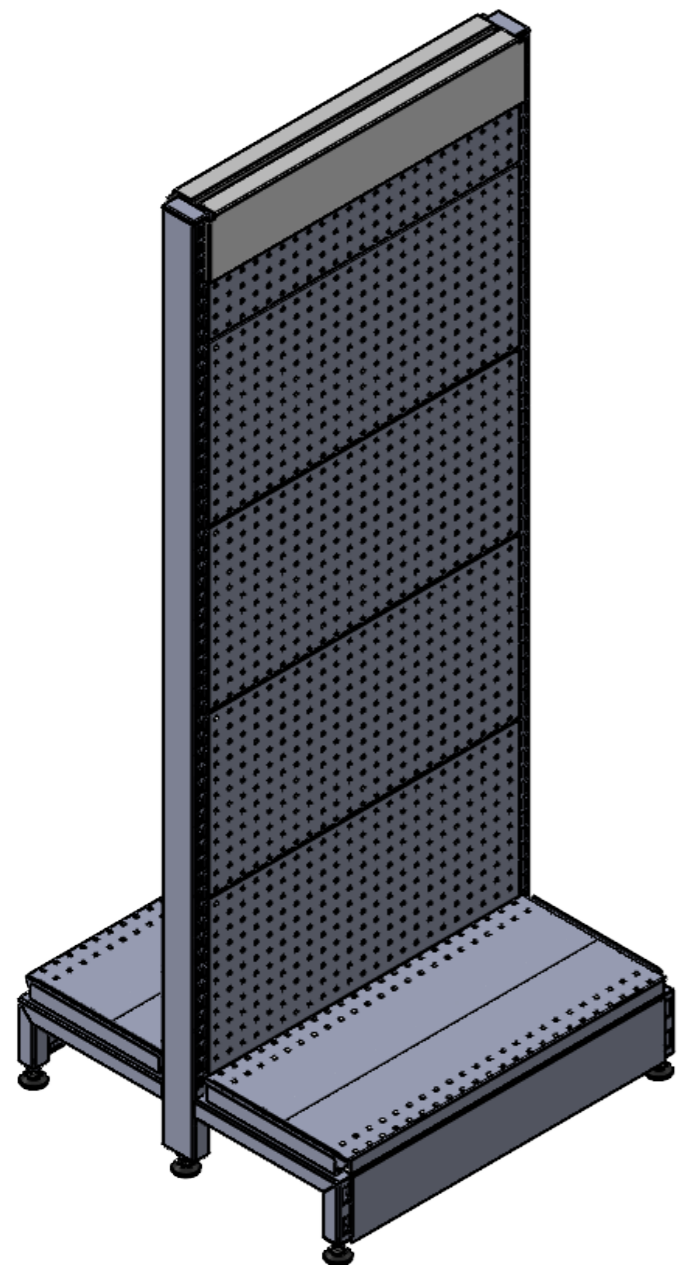

Rev	Date	Description

ALL DIMENSIONS IN (mm)
UNLESS OTHERWISE SPECIFIED
BREAK ALL SHARP EDGES

TOLERANCES
(BEFORE PAINTING
& AFTER PLATING)
X ± 1.00
X.X ± 0.50
X.XX ± 0.10
ANGLES ± 0.5°

A02- RENDER
CLIENT: RFA1000
PROJ. NO.: TBA
PART NO.: --
Revision --
Page 2

**RFA1016 600(W) X 1515 (H) DOUBLE
SIDED GONDOLA BAY-PERFORATED
- START BAY**

PRODUCT CODE: **RFA1016**

Date: 26/10/2022
Drawn by: DH
Checked by: --

DO NOT SCALE
Scale@A3 1:15

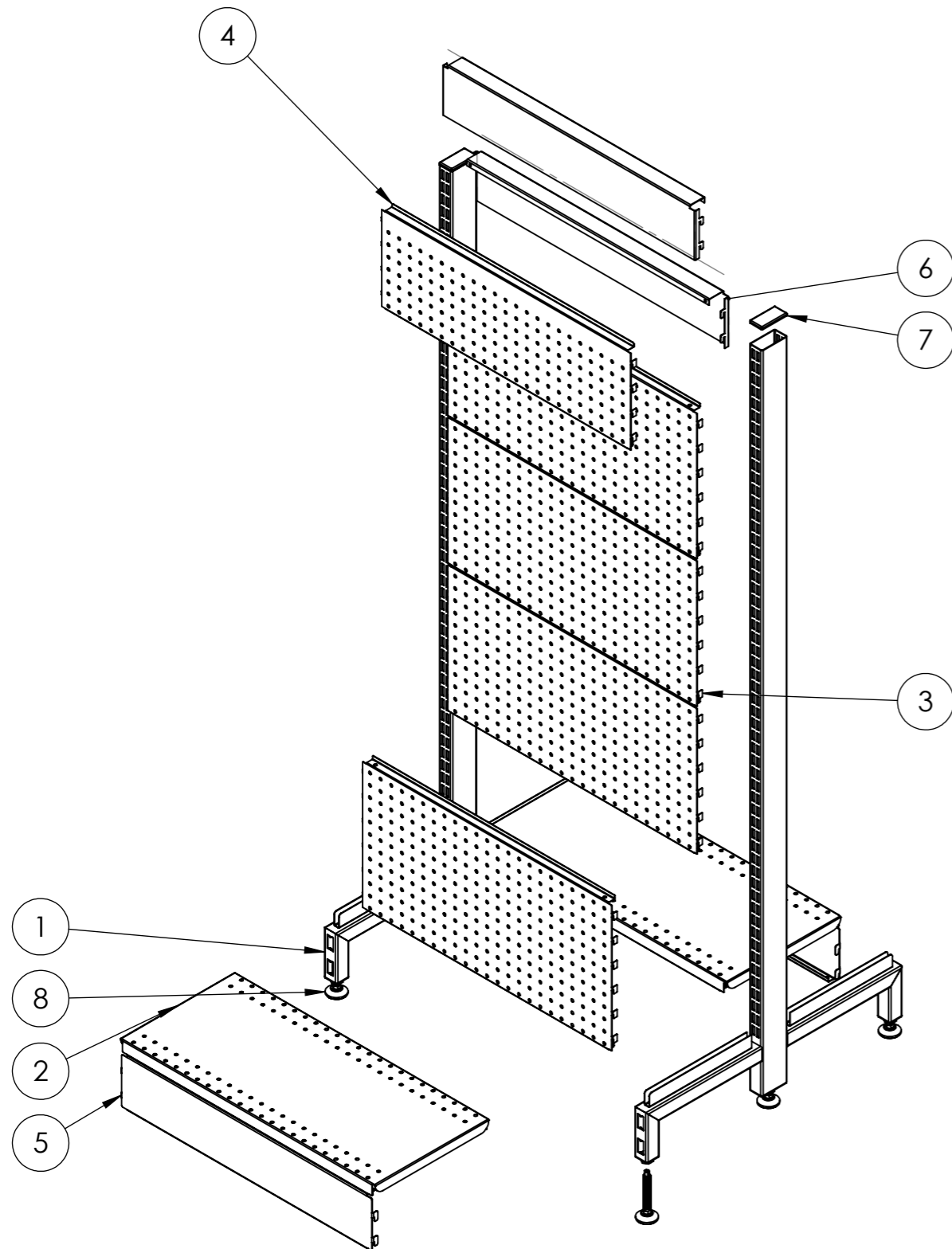

ITEM NO.	DESCRIPTION	QTY.
1	DOUBLE SIDED POST	2
2	600X270 SHELF	2
3	600W x 300H PERF PANEL	4
4	600W X 200H PERF. PANEL	1
5	BOTTOM SKIRT	2
6	SNAP IN TOP CAP	2
7	PLASTIC ENDCAP	2
8	ADJ. FEET	6

Rev	Date	Description

ALL DIMENSIONS IN (mm)
UNLESS OTHERWISE SPECIFIED
BREAK ALL SHARP EDGES

TOLERANCES
(BEFORE PAINTING
& AFTER PLATING)
X ± 1.00
X.X ± 0.50
X.XX ± 0.10
ANGLES ± 0.5°

A09- EXPLODED
CLIENT: RFA1000
PROJ. NO.: TBA
PART NO.: --
Revision --
Page 9

**RFA1016 600(W) X 1515 (H) DOUBLE
SIDED GONDOLA BAY-PERFORATED
- START BAY**

PRODUCT CODE: RFA1016	
Date: 26/10/2022	
Drawn by: DH	DO NOT SCALE
Checked by: --	Scale@A3 1:20