

AP ASSOCIATED PROJECTS COMMERCIAL BUILDERS,
PROJECT MANAGERS,
PLANNERS & DESIGNERS

T 03 8787 3000 F 03 8787 3025
48-58 Cyber Loop, Dandenong South VIC 3175

Rev	Date	Description

ALL DIMENSIONS IN (mm)
UNLESS OTHERWISE SPECIFIED
BREAK ALL SHARP EDGES

TOLERANCES
(BEFORE PAINTING
& AFTER PLATING)
X ± 1.00
X.X ± 0.50
X.XX ± 0.10
ANGLES ± 0.5°

A01- RENDER
CLIENT: RFA
PROJ. NO.: TBA
PART NO.: --
Revision --
Page 1

600mm (W) x 2415mm (H) x 270mm (D) WALL BAY - PERFORATED W/ SKIRT DRAWER START BAY (PEARL WHITE)		
PRODUCT CODE: RFA1002		
Date:	2/11/2022	DO NOT SCALE
Drawn by	CB	
Checked by	--	
		Scale@A3 1:1

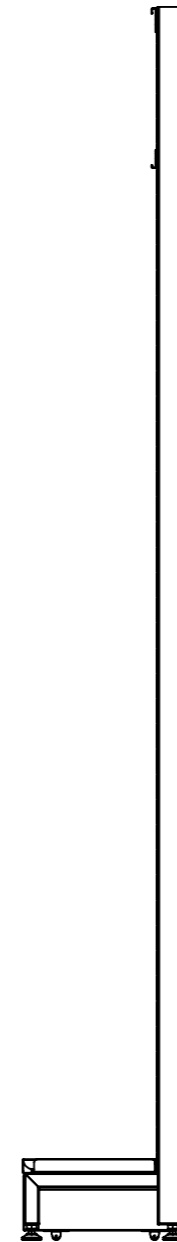
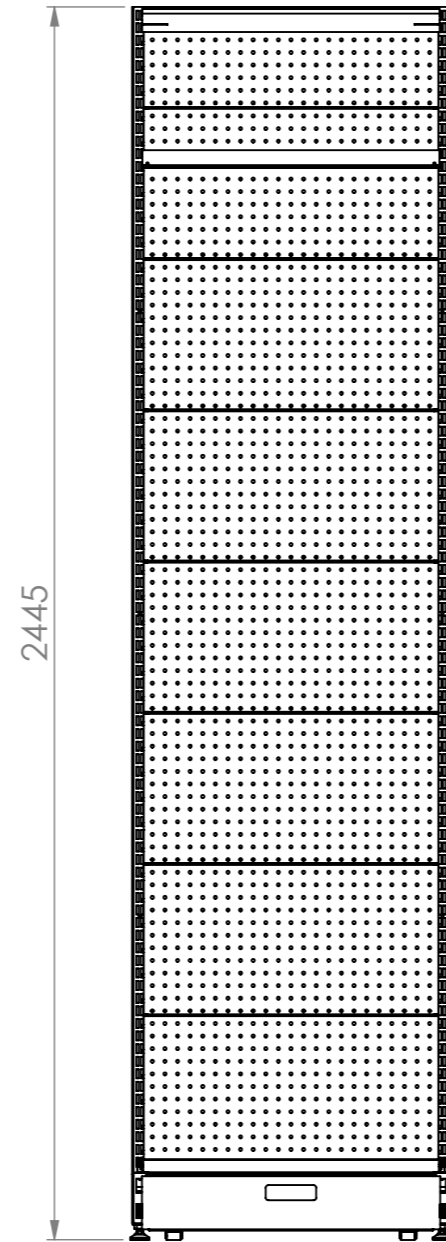
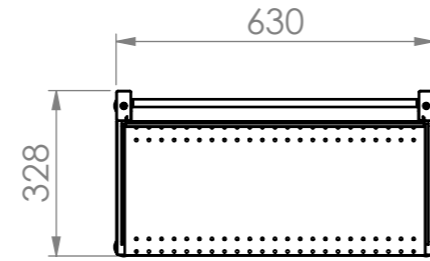
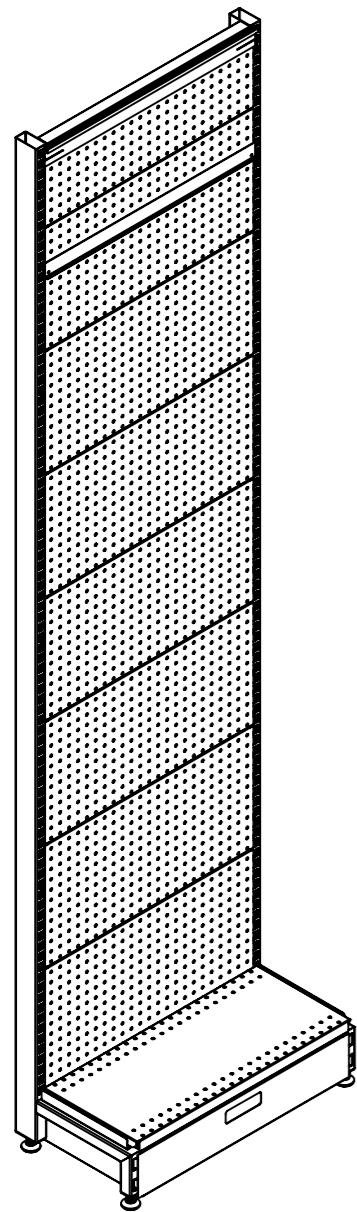

Rev	Date	Description

ALL DIMENSIONS IN (mm)
UNLESS OTHERWISE SPECIFIED
BREAK ALL SHARP EDGES

TOLERANCES
(BEFORE PAINTING
& AFTER PLATING)
X ± 1.00
X.X ± 0.50
X.XX ± 0.10
ANGLES ± 0.5°

A03- DIMENSIONS
CLIENT: RFA
PROJ. NO.: TBA
PART NO.: --
Revision --
Page 3

600mm (W) x 2415mm (H) x 270mm (D) WALL BAY - PERFORATED W/ SKIRT DRAWER START BAY		
PRODUCT CODE: RFA1002/RFA1059	Date: 28/10/2022	
Drawn by CB	Checked by --	DO NOT SCALE
		Scale@A3 1:15

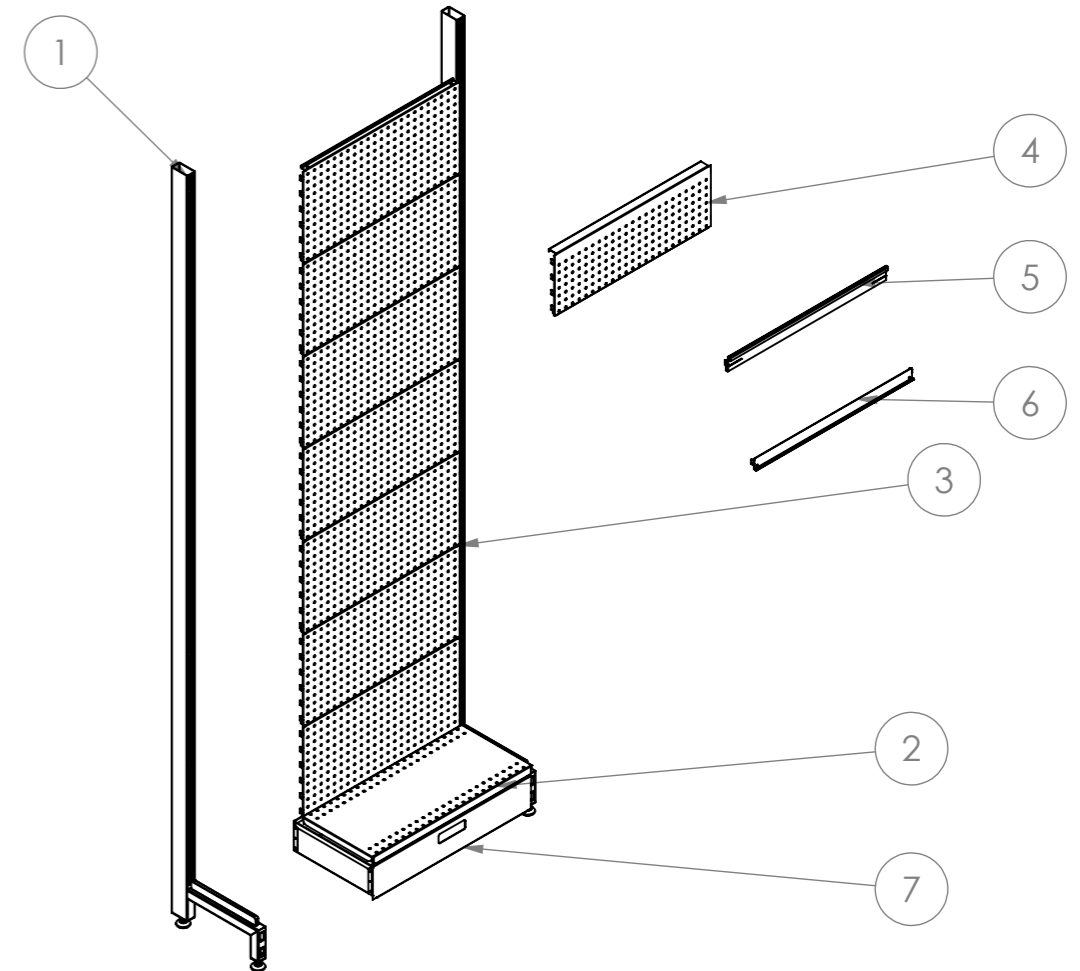
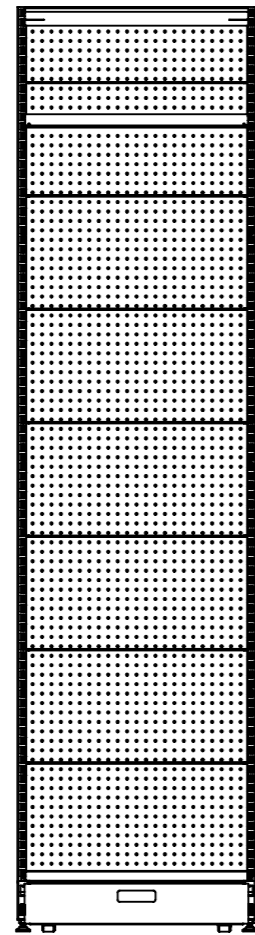
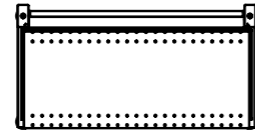
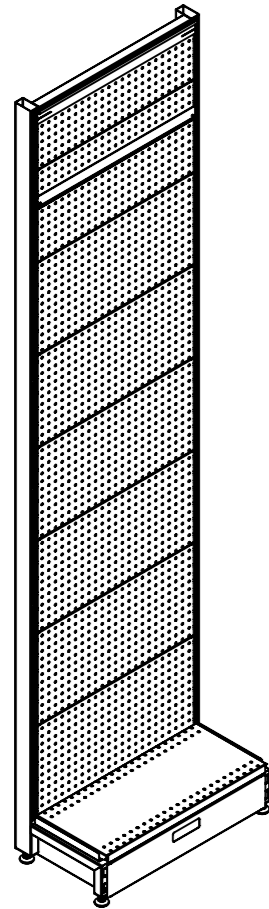

ITEM NO.	SW-File Name(File Name)	QTY.
1	RFA1100 2400mm (H) WALL BAY POST	2
2	RFA1321-RFA1322 600X270 STEEL SHELF	1
3	RFA1101-RFA1201 600X300 PERF PANEL	7
4	RFA1103-RFA1203 600X200 PERF PANEL	1
5	RFA1116 600mm (W) SIGNAGE TOP BRACKET	1
6	RFA1117 600mm (W) SIGNAGE BOTTOM BRACKET	1
7	AP1000 DRAWER SKIRT Assy	1

Rev	Date	Description

ALL DIMENSIONS IN (mm)
UNLESS OTHERWISE SPECIFIED
BREAK ALL SHARP EDGES

TOLERANCES
(BEFORE PAINTING
& AFTER PLATING)
X ± 1.00
X.X ± 0.50
X.XX ± 0.10
ANGLES ± 0.5°

A04- EXPLODED

CLIENT: RFA
PROJ. NO.: TBA
PART NO.: --
Revision --
Page 4

600mm (W) x 2415mm (H) x 270mm (D)
WALL BAY - PERFORATED W/ SKIRT DRAWER
START BAY

PRODUCT CODE: **RFA1002/RFA1059**

Date: 28/10/2022

Drawn by CB

Checked by --

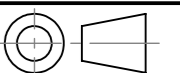

DO NOT SCALE

Scale@A3 1:20