

T 03 8787 3000 F 03 8787 3025  
 48-58 Cyber Loop, Dandenong South  
 VIC 3175 (AUSTRALIA)

© COPYRIGHT. This drawing is the exclusive property of Associated Projects Pty Ltd. It is subject to protection and is strictly confidential. Reproduction in whole or in part is prohibited without obtaining prior permission in writing from the proprietor.

Rev	Date	Description

ALL DIMENSIONS IN (mm)  
 UNLESS OTHERWISE SPECIFIED  
 BREAK ALL SHARP EDGES

TOLERANCES  
 (BEFORE PAINTING  
 & AFTER PLATING)  
 X ± 1.00  
 X.X ± 0.50  
 X.XX ± 0.10  
 ANGLES ± 0.5°

A01- RENDER  
 CLIENT: RFA  
 PROJ. NO.: TBA  
 FINISH: P/C MATTE BLACK  
 MAT'L: MILD STEEL  
 Page 1

STRAIGHT CLOTHES HANGING ARM (FRONT HANG)  
 - D400 - FOR HANG RAIL

PRODUCT CODE: **RFA0445**

Date: 10/11/2023

Drawn by DH

Checked by NP

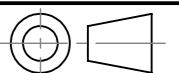

DO NOT SCALE

Scale@A3 1:5

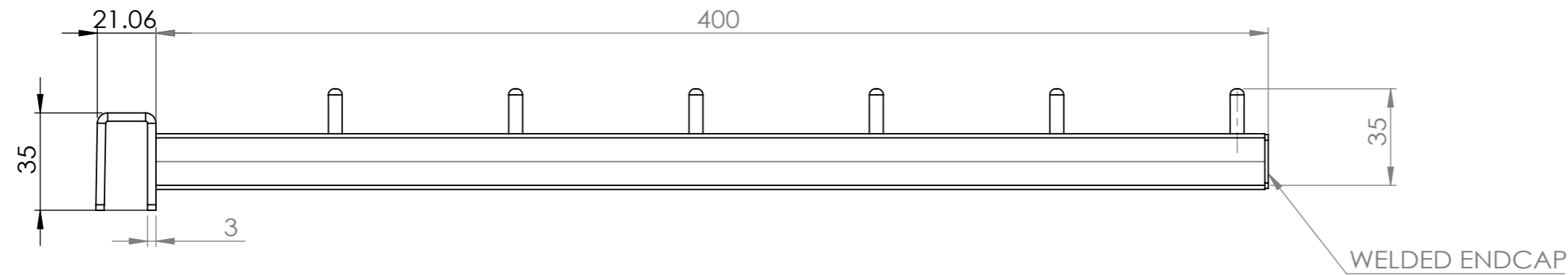
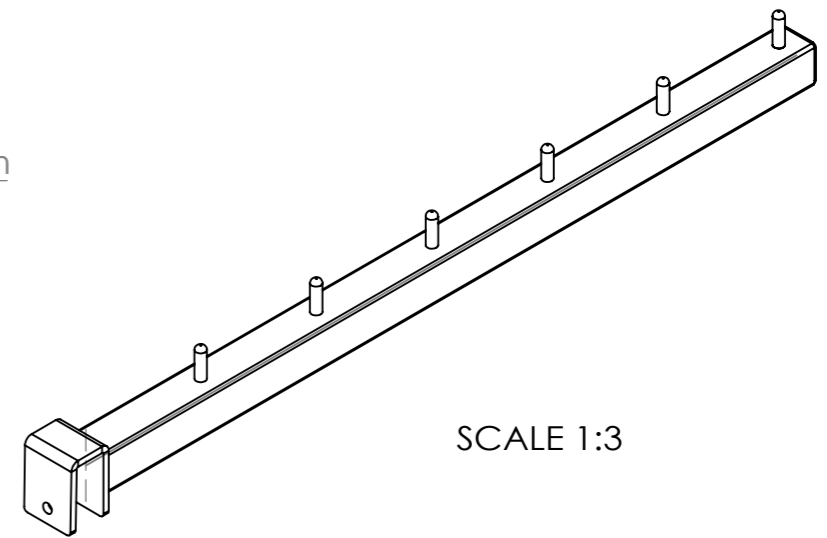
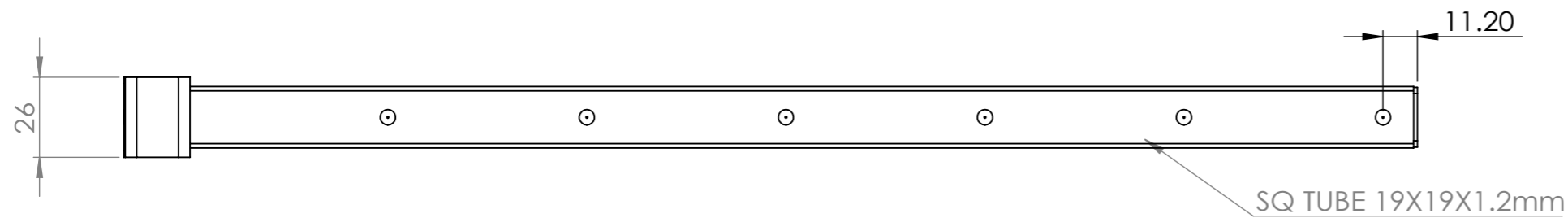

T 03 8787 3000 F 03 8787 3025  
48-58 Cyber Loop, Dandenong South  
VIC 3175 (AUSTRALIA)

© COPYRIGHT. This drawing is the exclusive property of Associated Projects Pty Ltd. It is subject to protection and is strictly confidential. Reproduction in whole or in part is prohibited without obtaining prior permission in writing from the proprietor.

Rev	Date	Description

ALL DIMENSIONS IN (mm)  
UNLESS OTHERWISE SPECIFIED  
BREAK ALL SHARP EDGES

TOLERANCES  
(BEFORE PAINTING  
& AFTER PLATING)  
X ± 1.00  
X.X ± 0.50  
X.XX ± 0.10  
ANGLES ± 0.5°

A02- CLIENT  
CLIENT: RFA  
PROJ. NO.: TBA  
FINISH: P/C MATTE BLACK  
MAT'L: MILD STEEL  
Page 2

STRAIGHT CLOTHES HANGING ARM (FRONT HANG)  
= D400 - FOR HANG RAIL

PRODUCT CODE: **RFA0445**

Date: 10/11/2023

Drawn by DH

Checked by NP

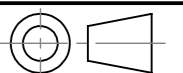

DO NOT SCALE

Scale@A3 1:2