

T 03 8787 3000 F 03 8787 3025  
 48-58 Cyber Loop, Dandenong South  
 VIC 3175 (AUSTRALIA)

© COPYRIGHT. This drawing is the exclusive property of Associated Projects Pty Ltd. It is subject to protection and is strictly confidential. Reproduction in whole or in part is prohibited without obtaining prior permission in writing from the proprietor.

Rev	Date	Description

ALL DIMENSIONS IN (mm)  
 UNLESS OTHERWISE SPECIFIED  
 BREAK ALL SHARP EDGES

TOLERANCES  
 (BEFORE PAINTING  
 & AFTER PLATING)  
 X ± 1.00  
 X.X ± 0.50  
 X.XX ± 0.10  
 ANGLES ± 0.5°

A01- RENDER  
 CLIENT: RFA2000  
 PROJ. NO.: TBA  
 FINISH: P/C MATTE BLACK  
 MAT'L:  
 Page 1

SHELF - W900XD350 - W/. DOUBLE STIFFENER

PRODUCT CODE: **RFA0409**  
 Date: 3/10/2023  
 Drawn by DH  
 Checked by NP

DO NOT SCALE  
 Scale@A3 1:5

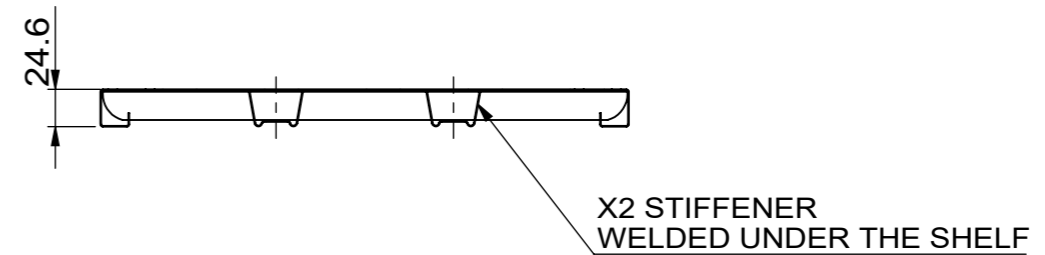
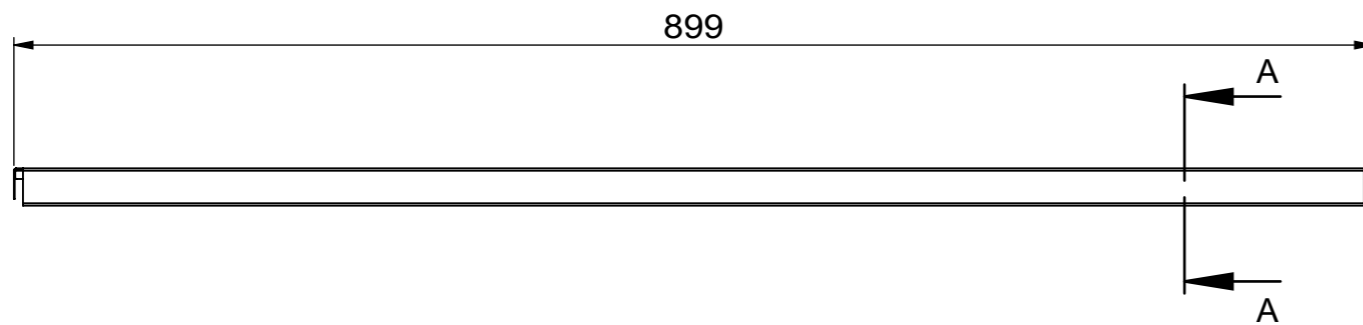
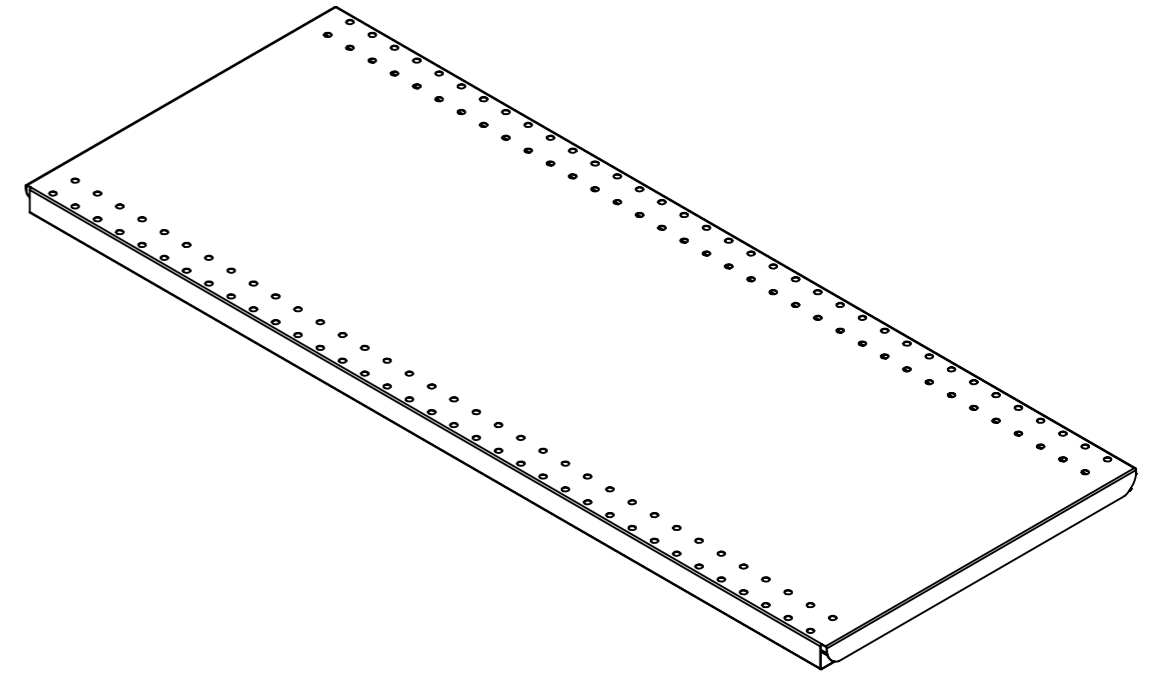
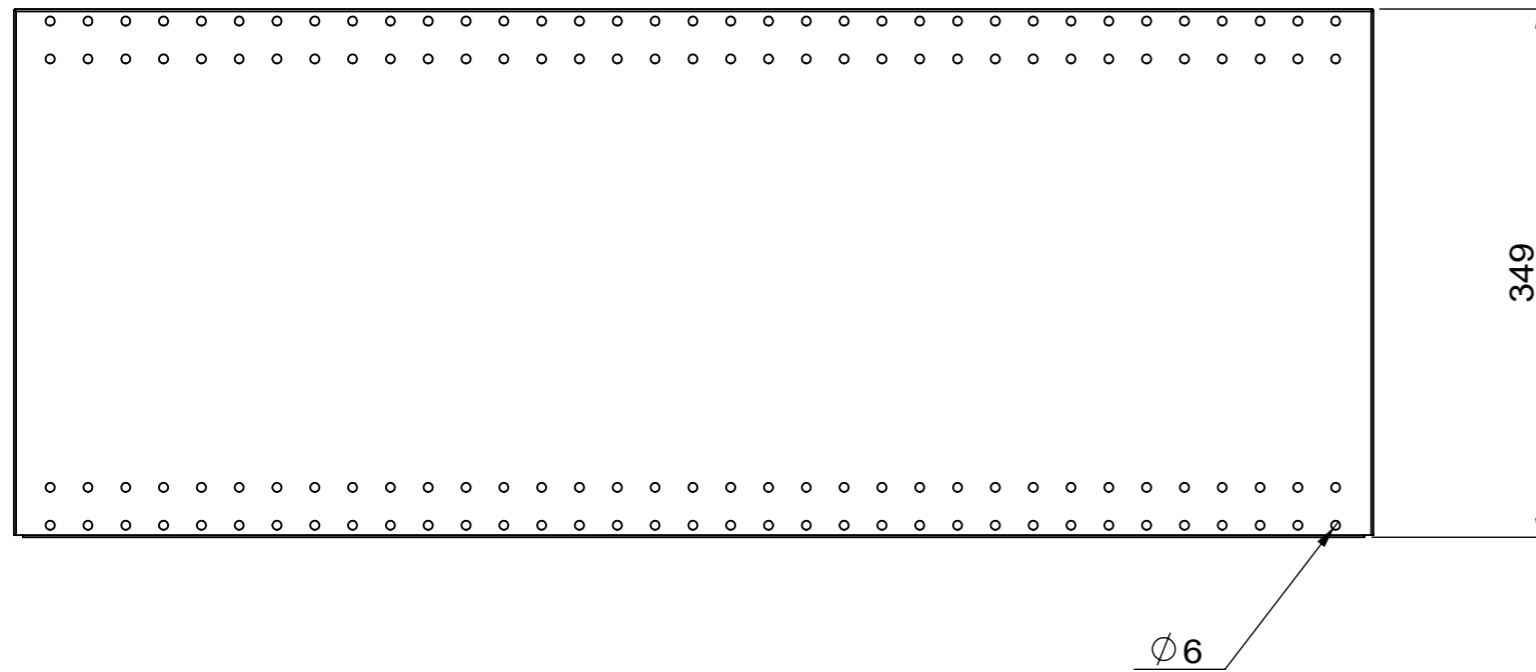

SECTION A-A



T 03 8787 3000 F 03 8787 3025  
48-58 Cyber Loop, Dandenong South  
VIC 3175 (AUSTRALIA)

© COPYRIGHT. This drawing is the exclusive property of Associated Projects Pty Ltd. It is subject to protection and is strictly confidential. Reproduction in whole or in part is prohibited without obtaining prior permission in writing from the proprietor.

Rev	Date	Description

ALL DIMENSIONS IN (mm)  
UNLESS OTHERWISE SPECIFIED  
BREAK ALL SHARP EDGES

TOLERANCES  
(BEFORE PAINTING  
& AFTER PLATING)  
X ± 1.00  
X.X ± 0.50  
X.XX ± 0.10  
ANGLES ± 0.5°

A02- CLIENT  
CLIENT: RFA2000  
PROJ. NO.: TBA  
FINISH: P/C MATTE BLACK  
MAT'L:  
Page 2

SHELF - W900XD350 - W/ DOUBLE STIFFENER

PRODUCT CODE: **RFA0409**

Date: 3/10/2023

Drawn by DH

Checked by NP

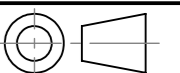

DO NOT SCALE

Scale@A3 1:5