



FINISH: P/C MATTE BLACK

AP ASSOCIATED PROJECTS COMMERCIAL BUILDERS,
PROJECT MANAGERS,
PLANNERS & DESIGNERS

T 03 8787 3000 F 03 8787 3025
48-58 Cyber Loop, Dandenong South VIC 3175

Rev	Date	Description

ALL DIMENSIONS IN (mm)
UNLESS OTHERWISE SPECIFIED
BREAK ALL SHARP EDGES

TOLERANCES
(BEFORE PAINTING
& AFTER PLATING)
X ± 1.00
X.X ± 0.50
X.XX ± 0.10
ANGLES ± 0.5°

A01- RENDER
CLIENT: RFA
PROJ. NO.: TBA
PART NO.: --
Revision --
Page 1

SECURITY DISPLAY CABINET W900 x H1800 x D200		
-		
PRODUCT CODE: RFA0104		
Date:	17/01/2024	
Drawn by	PS	
Checked by	--	
		DO NOT SCALE
		Scale@A3 1:20

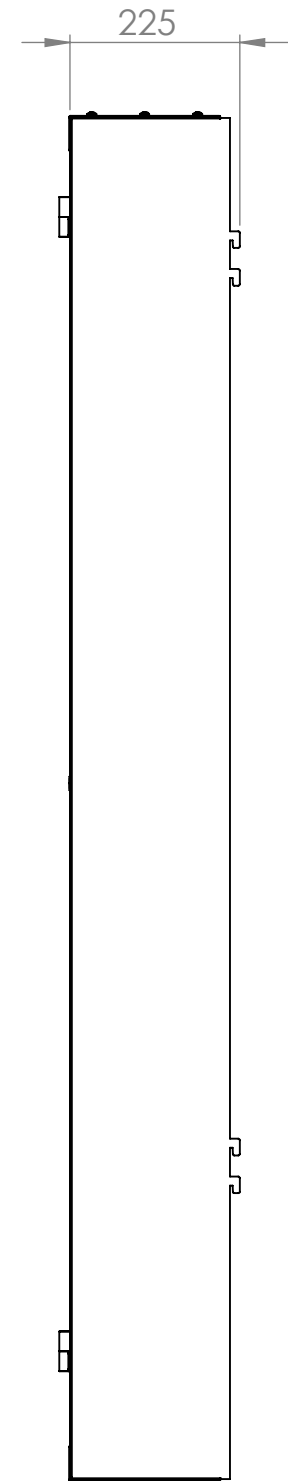
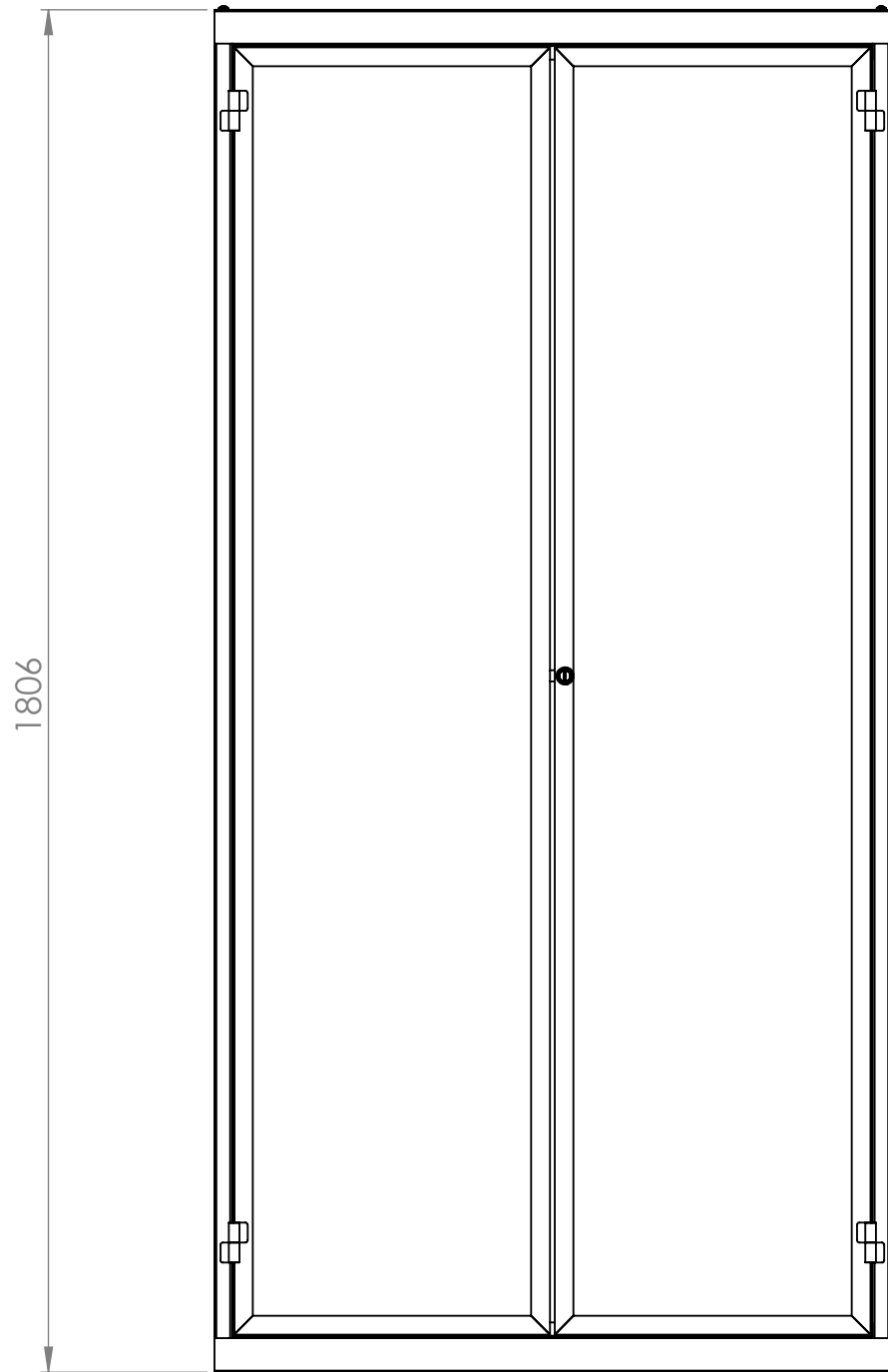
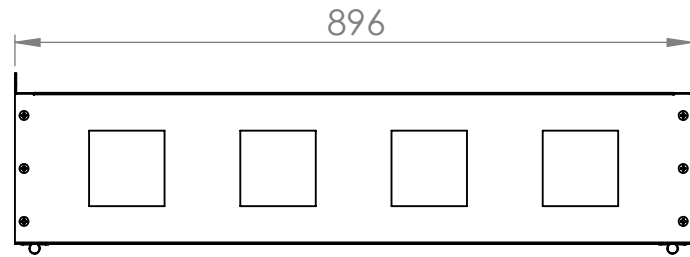
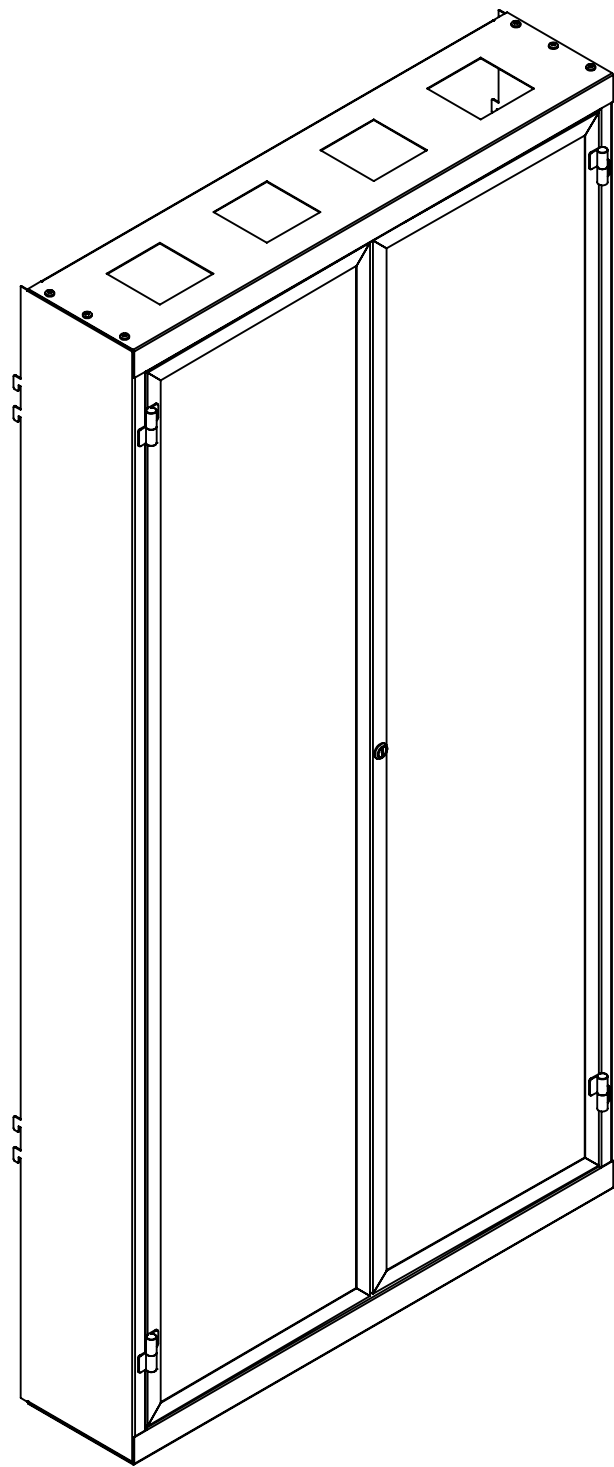

Rev	Date	Description

ALL DIMENSIONS IN (mm)
UNLESS OTHERWISE SPECIFIED
BREAK ALL SHARP EDGES

TOLERANCES
(BEFORE PAINTING
& AFTER PLATING)
X ± 1.00
X.X ± 0.50
X.XX ± 0.10
ANGLES ± 0.5°

A02- DIMENSIONS

CLIENT: RFA
PROJ. NO.: TBA
PART NO.: --
Revision --
Page 2

SECURITY DISPLAY CABINET
W900 x H1800 x D200

PRODUCT CODE: **RFA0104**

Date: 17/01/2024

Drawn by PS

Checked by --

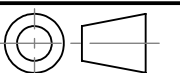

DO NOT SCALE

Scale@A3 1:10

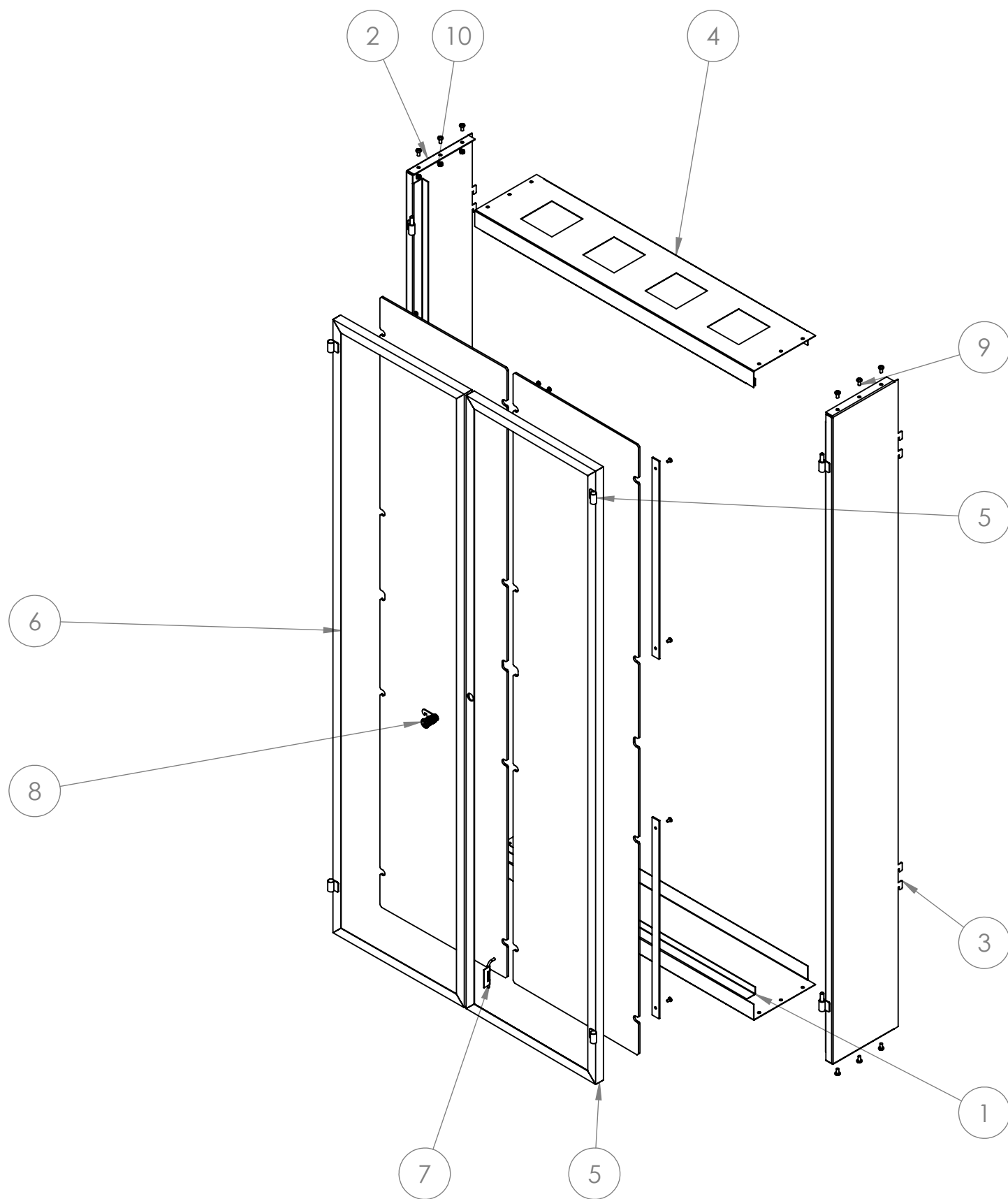

ITEM NO.	PartNo	DESCRIPTION	QTY.
1		BASE	1
2		LHS PANEL	1
3		RHS PANEL	1
4		TOP PANEL	1
5		RHS DOOR	1
6		LHS DOOR	1
7		DOOR LATCH	1
8		CAM LOCK	1
9		M6x12mm PAN CHS	12
10		M6 NUT	12

Rev	Date	Description

ALL DIMENSIONS IN (mm)
UNLESS OTHERWISE SPECIFIED
BREAK ALL SHARP EDGES

TOLERANCES
(BEFORE PAINTING
& AFTER PLATING)
X ± 1.00
X.X ± 0.50
X.XX ± 0.10
ANGLES ± 0.5°

A03- EXPLODED

CLIENT: RFA

PROJ. NO.: TBA

PART NO.: --

Revision --

Page 3

SECURITY DISPLAY CABINET
W900 x H1800 x D200

PRODUCT CODE: **RFA0104**

Date: 17/01/2024

Drawn by PS

Checked by --

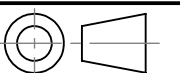

DO NOT SCALE

Scale@A3 1:10