

**FINISH: CHROME PLATED**



T 03 8787 3000 F 03 8787 3025  
48-58 Cyber Loop, Dandenong South  
VIC 3175 (AUSTRALIA)

© COPYRIGHT. This drawing is the exclusive property of Associated Projects Pty Ltd. It is subject to protection and is strictly confidential. Reproduction in whole or in part is prohibited without obtaining prior permission in writing from the proprietor.

Rev	Date	Description

ALL DIMENSIONS IN (mm)  
UNLESS OTHERWISE SPECIFIED  
BREAK ALL SHARP EDGES

TOLERANCES  
(BEFORE PAINTING  
& AFTER PLATING)  
X ± 1.00  
X.X ± 0.50  
X.XX ± 0.10  
ANGLES ± 0.5°

**A01- RENDER**  
**CLIENT: -**  
**PROJ. NO.: TBA**  
**FINISH: CHROME**  
**MAT'L: MILD STEEL**  
**Page 1**

**HOOK - DOUBLE PRONG 100MM - FOR  
PERFORATED PANEL - W/ FLIP SCAN - CHROME**

<b>PRODUCT CODE: RFA0009</b>		
Date:	29/08/2024	
Drawn by	DH	DO NOT SCALE
Checked by	NP	Scale@A3 1:1

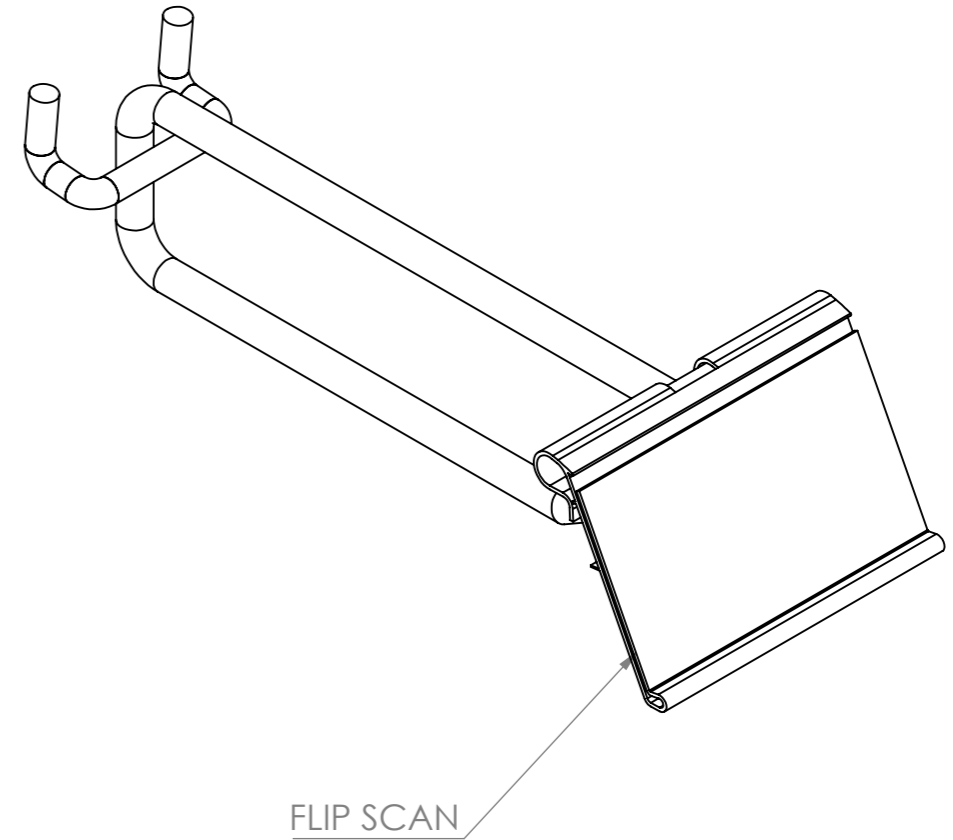
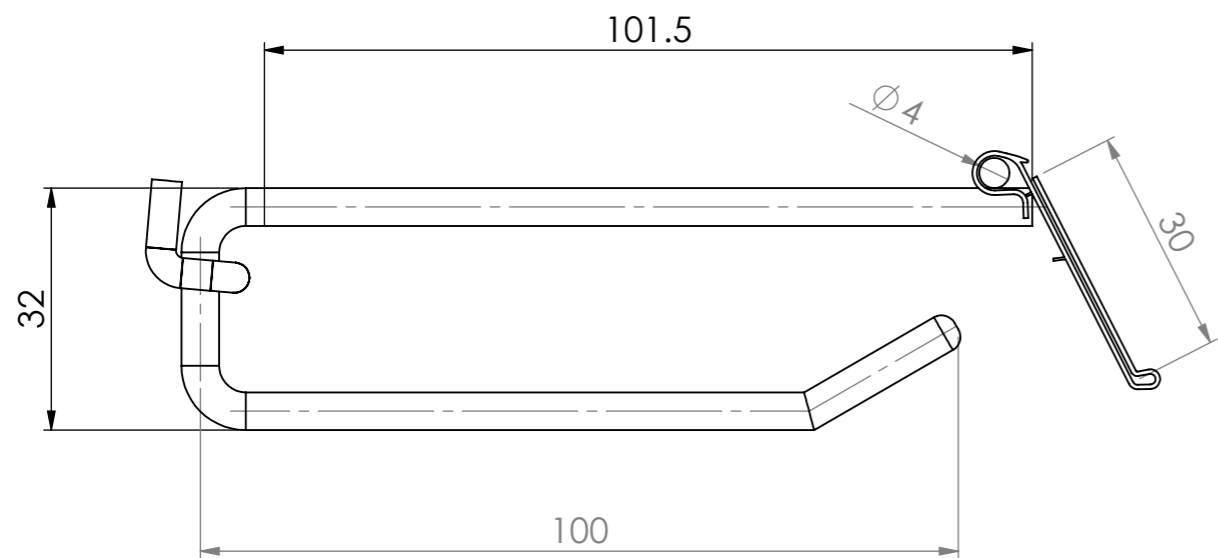
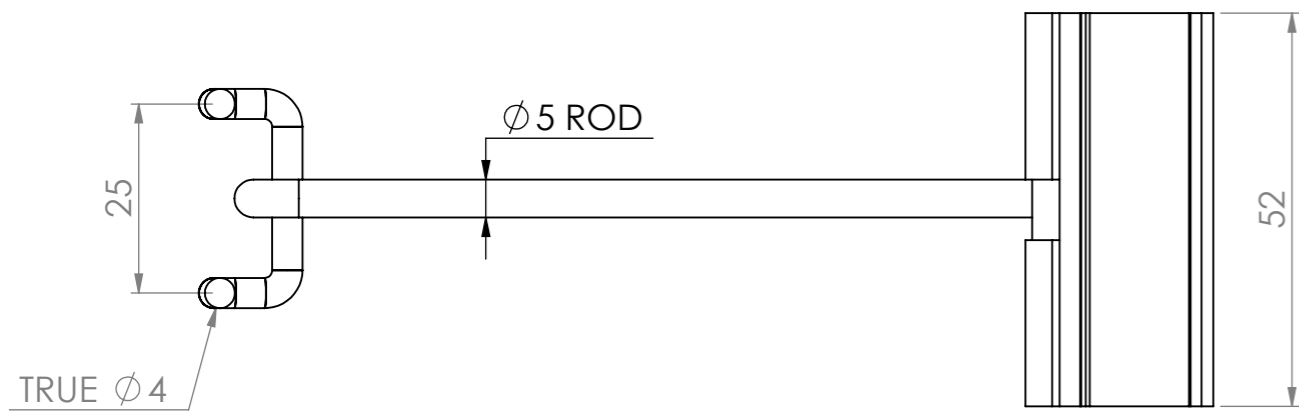

T 03 8787 3000 F 03 8787 3025  
48-58 Cyber Loop, Dandenong South  
VIC 3175 (AUSTRALIA)

© COPYRIGHT. This drawing is the exclusive property of Associated Projects Pty Ltd. It is subject to protection and is strictly confidential. Reproduction in whole or in part is prohibited without obtaining prior permission in writing from the proprietor.

Rev	Date	Description

ALL DIMENSIONS IN (mm)  
UNLESS OTHERWISE SPECIFIED  
BREAK ALL SHARP EDGES

TOLERANCES  
(BEFORE PAINTING  
& AFTER PLATING)  
X  $\pm$  1.00  
X.X  $\pm$  0.50  
X.XX  $\pm$  0.10  
ANGLES  $\pm$  0.5°

A02- CLIENT

CLIENT: -

PROJ. NO.: TBA

FINISH: CHROME

MAT'L: MILD STEEL

Page 2

HOOK - DOUBLE PRONG 100MM - FOR  
PERFORATED PANEL - W/ FLIP SCAN - CHROME

PRODUCT CODE: **RFA0009**

Date: 29/08/2024

Drawn by DH

Checked by NP

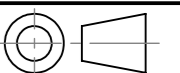

DO NOT SCALE

Scale@A3 1:1