



FINISH: CHROME



T 03 8787 3000 F 03 8787 3025
48-58 Cyber Loop, Dandenong South
VIC 3175 (AUSTRALIA)

© COPYRIGHT. This drawing is the exclusive property of Associated Projects Pty Ltd. It is subject to protection and is strictly confidential. Reproduction in whole or in part is prohibited without obtaining prior permission in writing from the proprietor.

Rev	Date	Description

ALL DIMENSIONS IN (mm)
UNLESS OTHERWISE SPECIFIED
BREAK ALL SHARP EDGES

TOLERANCES
(BEFORE PAINTING
& AFTER PLATING)
X ± 1.00
X.X ± 0.50
X.XX ± 0.10
ANGLES ± 0.5°

A01- RENDER
CLIENT: -
PROJ. NO.: TBA
FINISH: CHROME
MAT'L: MILD STEEL
Page 1

HOOK - SINGLE PRONG 150MM - FOR PERFORATED PANEL - CHROME	
PRODUCT CODE: RFA0005	
Date: 22/01/2024	DO NOT SCALE
Drawn by DH	Scale@A3 1:1
Checked by NP	

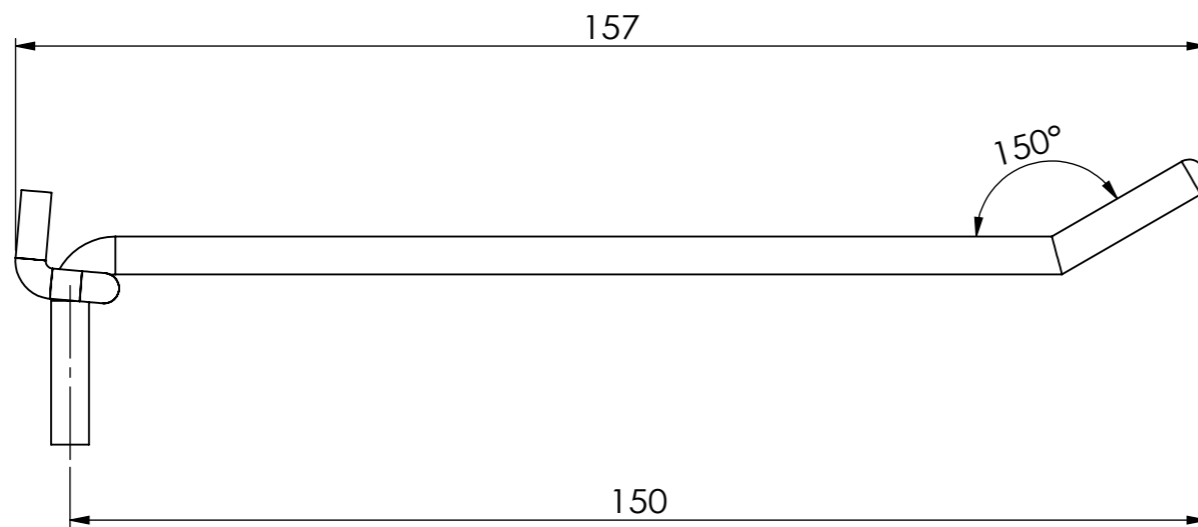
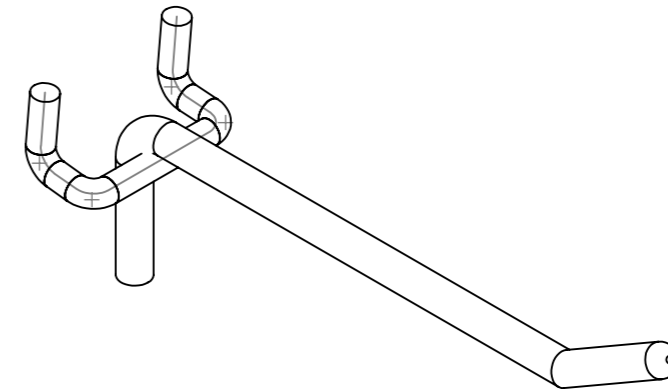
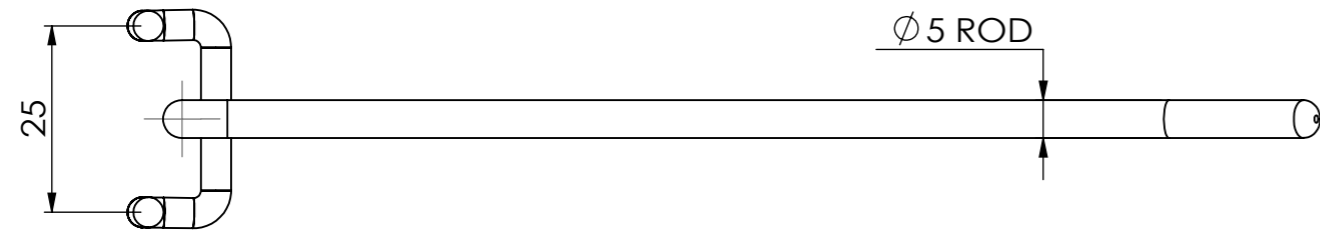

T 03 8787 3000 F 03 8787 3025
48-58 Cyber Loop, Dandenong South
VIC 3175 (AUSTRALIA)

© COPYRIGHT. This drawing is the exclusive property of Associated Projects Pty Ltd. It is subject to protection and is strictly confidential. Reproduction in whole or in part is prohibited without obtaining prior permission in writing from the proprietor.

Rev	Date	Description

ALL DIMENSIONS IN (mm)
UNLESS OTHERWISE SPECIFIED
BREAK ALL SHARP EDGES

TOLERANCES
(BEFORE PAINTING
& AFTER PLATING)
X ± 1.00
X.X ± 0.50
X.XX ± 0.10
ANGLES ± 0.5°

A02- -
CLIENT: -
PROJ. NO.: TBA
FINISH: CHROME
MAT'L: MILD STEEL
Page 2

HOOK - SINGLE PRONG 150MM - FOR PERFORATED
PANEL - CHROME

PRODUCT CODE: **RFA0005**

Date: 22/01/2024

Drawn by DH

Checked by NP

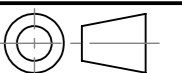

Scale@A3 1:1